



GENERAL FUELING PRODUCTS

Husky Catalog

Contents

Conventional Nozzles	5
XS® Nozzles	7
XS® MFM Nozzles	11
X Nozzles	15
1A Nozzles	19
1AS Nozzles	23
ECO Nozzles	27
Truck & High Volume Nozzles	31
VIIS Nozzles	33
VIII Nozzles	37
1HS Nozzles	41
1HSS Nozzles	45
1690/1691 Nozzles	49
Farm & Commercial Nozzles	53
XFS® Nozzles	55
1GS Nozzles	59
1GSS Nozzles	63
Diesel Exhaust Fluid Nozzles	67
SST DEF Nozzles	69
POLY DEF Nozzles	73
X DEF Nozzles	77
Conventional Ethanol Fueling Nozzles	81
XS® E25 Nozzles	83
X E85 Nozzles	87
XS® E85 Nozzles	91
Vapor Recovery Nozzles	95
V34 Nozzles	97
V34 COAX Nozzles	101
V34 ORVR Nozzles	105
V34iS Nozzles	109

Contents

Distilled Spirits Dispensing	113
SST WN Nozzles	115
X WN Nozzles	119
1A WN Nozzles	123
VIII WN Nozzles	127
1690 WN Nozzles	131
Swivels	135
Standard Swivels	137
Inline Swivels	139
F&C Standard Swivels	141
F&C High Volume Swivels	143
Vapor Recovery Swivels	145
High Volume Swivels	147
Ultra High Flow Swivels	149
DEF Swivels	151
E85 Swivel	153
Safe-T-Breaks®	155
Standard STB	157
MAG MAGBREAK®	159
F&C Standard STB	161
F&C High Volume STB	163
DEF Safe-T-Break®	165
High Volume STB	167
Balance Vapor STB	169
Vacuum Assist STB	171
E85 Safe-T-Breaks®	173
VAC Assist MAGBREAK®	175
E25 Safe-T-Breaks®	177
Inline STB	179
E25/E85 MAGBREAK®	181
Swivels/STB Combos	183
Standard Swivel/STB	185
High Volume Swivel/STB	187
Inline Combo Swivel/STB	189

Contents

Guards	191
Husky® Guards	193
Spouts	195
X, XS® Spouts	197
1GS Spouts	199
DEF Spouts	201
VIII, VIIIIS Spouts	203
V3 & V34 Spouts	205
E85 Spouts	207
PV Vents	209
PV Vents	211
Testing & Maintenance	215
Nozzle Service Kit	217
HCA Hose Conversion Adaptor	219
Mobile Fill Neck Device	221
Full Filter & Drain Cups	223
Flo-Equalizers®	225
Flo-Equalizer®	227
DEF Adaptors	229
DEF Adaptors	231
Hoses	233
EagleFlex® Hardwall	235
EagleFlex® Softwall	237
EagleFlex® Wirebraid	239
EagleFlex® Farm Tank	241
Whip Hoses	243
DEF Dispensing	245
EagleFlex® Low Perm Hardwall	247
Whip Low Perm Hoses	249
Fuel Oil Hose	251
EagleFlex® E0-E85	253
EZ-Connect®	255
EZ-Connect®	257



Conventional Nozzles

XS[®] Nozzles

CONVENTIONAL FUELLING

Pressure-activated, automatic shut-off nozzle for full-service and self-service stations.

- XS[®] nozzle shuts off when:
 - the pump shuts off.
 - the gas tank is full.
 - the lever is opened before the pump is turned on.
 - the leak detector has not completed the test cycle.
- Stainless steel reinforced spout bushing keeps spout tip round, and acts as a captive fastener to prevent tip-end sensor damage.
- Nozzle is equipped with a unique Flo-Stop[®] device that shuts off the nozzle if it falls from the fill neck or raises above the horizontal.
- *StreamShaper[®]* reduces turbulence for straighter fuel flow and less splash back spillage.
- Comes standard with smooth full grip guard.
- Tilt poppet design provides precise “to-the-penny” dispensing.
- Optional sightglass provides a clear window for the customer to view the fuel as it passes through the main poppet valve.
- Optional cold weather seals are rated to -40° F/C.
- Optional Gilbarco, Tokheim, and Wayne handguards can be fitted with a magnet to trigger the dispenser’s proximity switch, or can be provided without the magnet for dispensers equipped with a standard “flapper” switch.
- Optional Flo-Equalizer[®] prohibits the nozzle from exceeding 10 gpm (37.9 Lpm).
- Optional Drip Less spout mitigates the amount of fuel released from the spout tip after refueling is completed.
- ADA-compliant EZ Lever reduces the force required to open the main poppet valve by 50%, resulting in a lever operating force ≤5 lbs.

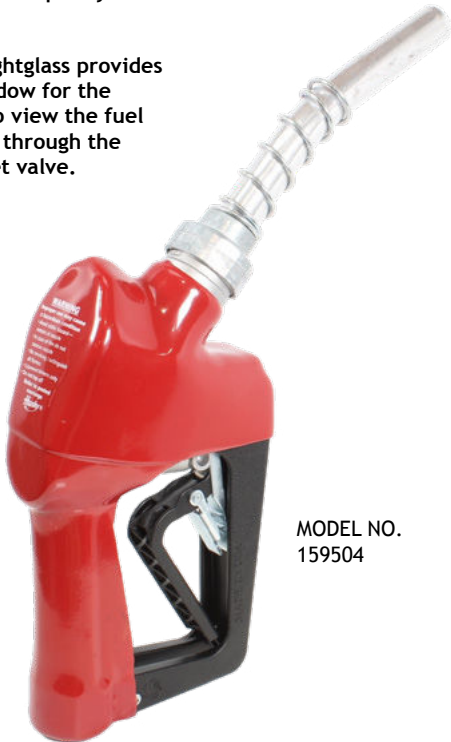

MODEL NO.
159504

New Unleaded Nozzles with NPT Inlet

MODEL NO.	DESCRIPTION	SHIPPING WEIGHT LBS (KG)
159504	with Two Notch Hold Open Clip	3.0 (1.4)
159508	without Hold Open Clip	3.0 (1.4)
159543	with Single Notch Hold Open Clip, 1808 Waffle Splash Guard and Flo-Equalizer [®]	3.2 (1.5)
159544	with Two Notch Hold Open Clip, 1808 Waffle Splash Guard and Flo-Equalizer [®]	3.2 (1.5)
159554	with Two Notch Hold Open Clip and Flo-Equalizer [®]	3.1 (1.4)
159554N	with Two Notch Hold Open Clip and Flo-Equalizer [®]	3.1 (1.4)
159559	with Two Notch Hold Open Clip and 1808 Waffle Splash Guard	3.1 (1.4)
159566	without Hold Open Clip, with 1808 Waffle Splash Guard	3.0 (1.4)
159576	with Two Notch Hold Open Clip and 1807 Waffle Splash Guard	3.1 (1.4)
159582	with Two Notch Hold Open Clip and Drip Less Spout	3.0 (1.4)
159595	with Two Notch Hold Open Clip, POPD [®] S and 1808 Waffle Splash Guard	3.2 (1.5)
498104	with Two Notch Hold Open Clip and Cold Weather Seals	3.0 (1.4)
498108	without Hold Open Clip, with Cold Weather Seals	3.0 (1.4)
E498159	with Two Notch Hold Open Clip, Mate Guard, Polymer Handle Cover, 1808 Waffle Splash Guard and Cold Weather Seals	3.1 (1.4)
498166	without Hold Open Clip, with 1808 Waffle Splash Guard and Cold Weather Seals	3.0 (1.4)
159504N [^]	with Two Notch Hold Open Clip	3.0 (1.4)
E159504	with Two Notch Hold Open Clip, Mate Guard and Polymer Handle Cover	3.0 (1.4)
E159504N [^]	with Two Notch Hold Open Clip, Mate Guard and Polymer Handle Cover	3.0 (1.4)
1595108	without Hold Open Clip, with POPD [®] S and 1808 Waffle Splash Guard	3.1 (1.4)
1595126	without Hold Open Clip, with POPD [®] S	3.1 (1.4)
1595146	with Two Notch Hold Open Clip, POPD [®] H and 1808 Waffle Splash Guard	3.1 (1.4)
1595179	with Single Notch Hold Open Clip and 1808 Waffle Splash Guard	3.1 (1.4)
1595214N	with Two Notch Hold Open Clip, 1” Longer Spout and Barbed Vent Tube Fitting	3.1 (1.4)
E159559	with Two Notch Hold Open Clip, 1808 Waffle Splash Guard, Mate Guard and Polymer Handle Cover	3.1 (1.4)
E1302704N [^]	with Two Notch Hold Open Clip, Mate Guard, Polymer Handle Cover, and Gradual Pressure Relief	3.0 (1.4)
E1595287	with Two Notch Hold Open Clip, Mate Guard, Polymer Handle Cover, 1807 Waffle Splash Guard	3.1 (1.4)

[^] NOT LISTED

New Unleaded Nozzles with BSP Inlet

MODEL NO.	DESCRIPTION	SHIPPING WEIGHT LBS (KG)
E159516N	with Two Notch Hold Open Clip, Mate Guard and Polymer Handle Cover	3.0 (1.4)
E1523016N	with Two Notch Hold Open Clip, Mate Guard, Polymer Handle Cover, and Wayne Magnetic Hanguard	3.3 (1.5)
E1595245	with Two Notch Hold Open Clip, Mate Guard, Polymer Handle Cover, 1808 Waffle Splash Guard and Drip Less Spout	3.1 (1.4)
E1595286	with Hold Open Clip, Mate Guard, Polymer Handle Cover, 1807 Waffle Splash Guard	3.1 (1.4)

[^] NOT LISTED



II 1 G
EN 13012
TYPE 1



WARNING: Cancer and Reproductive Harm - www.P65Warnings.ca.gov

XS[®] Nozzles

Pressure-activated, automatic shut-off nozzle for full-service and self-service stations.

Dimensions

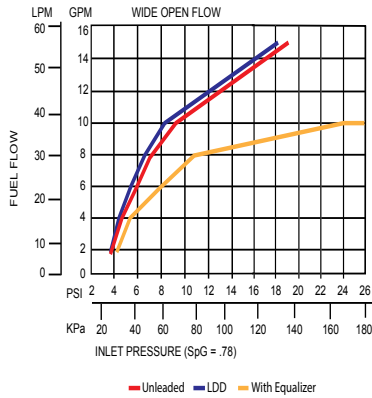
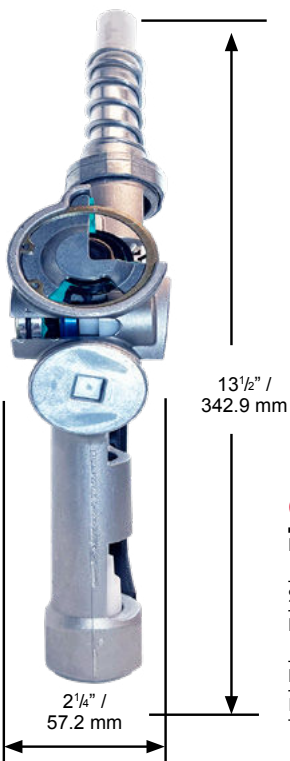

Construction

Body	One piece die cast aluminum with high-impact polymer handguard
Seals	Fluorocarbon
Packing	Double o-ring seal protected by fiber-reinforced Teflon [®]
Lever	Two Piece Polymer EZ Lever
Inlet	3/4" (19 mm) NPT or 3/4" (19 mm) BSP

New Light Duty Diesel Nozzles with NPT Inlet

MODEL NO.	DESCRIPTION	SHIPPING WEIGHT LBS (KG)
159503	with Two Notch Hold Open Clip	3.0 (1.4)
159507	without Hold Open Clip	3.0 (1.4)
159545	with Two Notch Hold Open Clip, 1808 Waffle Splash Guard and Flo-Equalizer [®]	3.2 (1.5)
159553	with Two Notch Hold Open Clip and Flo-Equalizer [®]	3.1 (1.4)
159561	with Two Notch Hold Open Clip and 1808 Waffle Splash Guard	3.1 (1.4)
159567	without Hold Open Clip, with 1808 Waffle Splash Guard	3.0 (1.4)
159578	with Two Notch Hold Open Clip and 1807 Waffle Splash Guard	3.1 (1.4)
159596	with Two Notch Hold Open Clip, POP D [®] S and 1808 Waffle Splash Guard	3.2 (1.5)
159597	with Single Notch Hold Open Clip and 1808 Waffle Splash Guard	3.1 (1.4)
498103	with Two Notch Hold Open Clip and Cold Weather Seals	3.0 (1.4)
498161	with Two Notch Hold Open Clip, 1808 Waffle Splash Guard and Cold Weather Seals	3.1 (1.4)
498167	without Hold Open Clip, with 1808 Waffle Splash Guard and Cold Weather Seals	3.0 (1.4)
1595171	with Single Notch Hold Open Clip, 1808 Waffle Splash Guard and Flo-Equalizer [®]	3.2 (1.5)
1595211	with Two Notch Hold Open Clip, 1808 Waffle Splash Guard and Drip Less Spout	3.1 (1.4)
159503N [^]	with Two Notch Hold Open Clip	3.0 (1.4)
E159503	with Two Notch Hold Open Clip, Mate Guard and Polymer Handle Cover	3.0 (1.4)
E159507	without Hold Open Clip, with Mate Guard and Polymer Handle Cover	3.0 (1.4)
E159561	with Two Notch Hold Open Clip, 1808 Waffle Splash Guard, Mate Guard and Polymer Handle Cover	3.1 (1.4)
E1595133N [^]	with Two Notch Hold Open Clip, Mate Guard, Polymer Handle Cover, and Gradual Pressure Relief	3.0 (1.4)
E159508	without Hold Open Clip with Mate Guard	3.0 (1.4)
E159567	without Hold Open Clip, Mate Guard with 1808 Waffle Splash Guard	3.2 (1.5)
E159596	with Two Notch Hold Open Clip, POPD [®] S, Mate Guard and 1808 Waffle Splash Guard	3.2 (1.5)
E498103	with Two Notch Hold Open Clip with Mate Guard and Cold Weather Seals	3.2 (1.5)
E1595211	with Hold Open Clip, Mate Guard, Polymer Handle Cover, 1808 Waffle Splash Guard, Drip Less Spout	3.1 (1.4)
E1595247	without Hold Open Clip, with Mate Guard, Polymer Handle Cover, 1808 Waffle Splash Guard and Drip Less Spout	3.1 (1.4)
E1595288	with Hold Open Clip, Mate Guard, Polymer Handle Cover, 1807 Waffle Splash Guard	3.1 (1.4)
1690803N [^]	with Two Notch Hold Open Clip, 1808 Waffle Splash Guard and Cold Weather Seals	3.0 (1.4)

[^] NOT LISTED

New Light Duty Diesel Nozzles with BSP Inlet

MODEL NO.	DESCRIPTION	SHIPPING WEIGHT LBS (KG)
E1595107	with Hold Open Clip, Mate Guard, Polymer Handle Cover, 1807 Waffle Splash Guard	3.1 (1.4)
E1595244	with Two Notch Hold Open Clip, Mate Guard, Polymer Handle Cover, 1808 Waffle Splash Guard and Drip Less Spout	3.1 (1.4)

[^] NOT LISTED

Pressure-activated, automatic shut-off nozzle for full-service and self-service stations.

Nozzle Options

Nozzle Guard Options



Full Grip Guard

POPD[®]S
Full Grip Guard

POPD[®]H
Full Grip Guard

Mate Guard

POPD[®]S
Mate Guard

POPD[®]H
Mate Guard

Waffle Guard Options



1807 Waffle Guard



1808 Waffle Guard

Handguard Options



Standard Polymer
Handguard

Gilbarco Polymer
Handguard
(with or without Magnet)

Tokheim Polymer
Handguard
(with or without Magnet)

Wayne Polymer
Handguard
(with or without Magnet)

Latch Plate Options

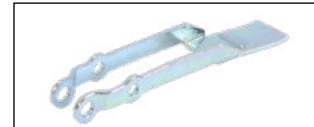

1 - Position Latch Plate

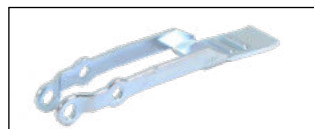

2 - Position Latch Plate

Lever Options



Lever without Hold
Open Clip



Lever with Hold
Open Clip

Flo-Equalizer[®] Option

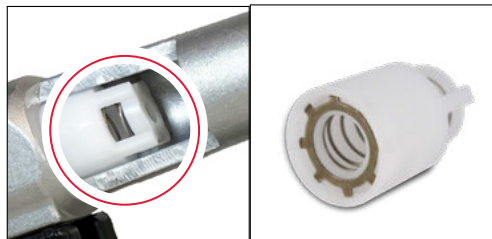

Sightglass Option



XS[®] Nozzles

Pressure-activated, automatic shut-off nozzle for full-service and self-service stations.

System Options

Safe-T-Breaks[®]

MODEL NO.	DESCRIPTION
002273	3/4" F x 3/4" F NPT Non-Reconnectable Safe-T-Break [®]
002774	3/4" F x 3/4" F BSPP Non-Reconnectable Safe-T-Break [®]
003360	3/4" F x 3/4" F NPT Reconnectable Safe-T-Break [®]
003385	3/4" F x 3/4" F BSPP Reconnectable Safe-T-Break [®]
005230	3/4" F x 3/4" F NPT Low Pull Reconnectable Safe-T-Break [®]
006130	3/4" F x 3/4" F NPT Non-Reconnectable PCC Safe-T-Break [®]
008330	3/4" F x 3/4" F NPT Reconnectable MAGBREAK [®]
009910	3/4" F x 3/4" F BSPP Reconnectable MAGBREAK [®]
010328	3/4" F x 3/4" F NPT Reconnectable High Pull MAGBREAK [®]
010330	3/4" F x 3/4" F BSPP Reconnectable High Pull MAGBREAK [®]
002774A	3/4" F x 3/4" F BSPP Non-Reconnectable Safe-T-Break [®] - Atex
003385A	3/4" F x 3/4" F BSPP Reconnectable Safe-T-Break [®] - Atex

Swivel/Safe-T-Break[®] Combos

MODEL NO.	DESCRIPTION
006310	3/4" M NPT Multi-Plane Swivel connected to 3/4" F NPT Reconnectable Safe-T-Break [®]
007085	3/4" M BSPP Multi-Plane Swivel connected to 3/4" F BSPP Reconnectable Safe-T-Break [®]
007085A	3/4" M BSPP Multi-Plane Swivel connected to 3/4" F BSPP Reconnectable Safe-T-Break [®] - Atex

Spouts

MODEL NO.	DESCRIPTION
001471	Light Duty Diesel Spout
001473	Unleaded Spout
010353	Light Duty Diesel Long Spout
010434	Unleaded Long Spout

Pressure/Vacuum Vents

MODEL NO.	DESCRIPTION
004620	2" Slip-On Pressure Vacuum Vent
004885	2" Thread-On Pressure Vacuum Vent - NPT
005885	2" Thread-On Pressure Vacuum Vent with Internal Screen - NPT

Accessories, Testing and Maintenance

MODEL NO.	DESCRIPTION
000397	Unleaded Spout Gauge
003593	Hold Open Clip Kit
004490	Conventional Flo-Equalizer [®] - 10 gpm / 37.9 Lpm
007089	Nozzle Service Kit
007490	Internal Flo-Equalizer [®] - 10 gpm / 37.9 Lpm

Swivels

MODEL NO.	DESCRIPTION
000350	3/4" M x 3/4" F NPT Multi-Plane Swivel
000355	3/4" M x 3/4" F NPT Multi-Plane Swivel Anodized Black
002272	3/4" M x 3/4" F NPT 90° Pump Swivel
002771	3/4" M x 3/4" F BSPP 90° Pump Swivel
002950	3/4" M x 3/4" F NPT Multi-Plane Restricted Swivel
003590	3/4" M x 3/4" F BSPP Multi-Plane Swivel
003895	3/4" M x 3/4" F NPT Inline Swivel
002771A	3/4" M x 3/4" F BSPP 90° Pump Swivel - Atex
003590A	3/4" M x 3/4" F BSPP Multi-Plane Swivel - Atex

Guards

MODEL NO.	DESCRIPTION
001506	Protection Package
001806	Full Grip Reguard
001807	Waffle Splash Guard with Small Hole
001808	Waffle Splash Guard
001809	Reguard Protection Package
003440	Mate Easy-On Package
003795	Mate Guard
004145	Full Grip Guard
006628	POPD [®] S Clear Cover
006665	POPD [®] S Full Grip Guard
007205	POPD [®] S Full Grip Reguard
007361	Black Handle Cover
007999	POPD [®] H Clear Cover
008165	POPD [®] S Mate Guard
008166	POPD [®] H Mate Guard
008175	POPD [®] EZS Nozzle Guard
008176	POPD [®] EZH Nozzle Guard
008185	POPD [®] H Full Grip Guard
008192	POPD [®] H Full Grip Reguard
014524	International Mate Package
014530	International Mate Guard
015247	International POPD [®] H Mate Guard
015253	International POPD [®] H Mate Package

Guard Color Chart

COLOR	SUFFIX	COLOR	SUFFIX	COLOR <i>CUSTOM</i>	SUFFIX
Blue	-01	Gold	-08	Amoco Blue	-07 <i>CUSTOM</i>
Red	-02	Silver	-09	Apple Green	-18 <i>CUSTOM</i>
Green	-03	BP Green	-16	Purple	-19 <i>CUSTOM</i>
Black	-04	M Blue	-21	Pink	-20 <i>CUSTOM</i>
Yellow	-05	Orange	-39	BPS Green	-22 <i>CUSTOM</i>
White	-06				

Scuff Guards are to be ordered with the corresponding guard color option added to the model number. Example: If BLUE guards are desired, add guard color option -01 to the model number (159504-01). For custom colors, a minimum order of 4,000 guards will be required.

XS[®] MFM Nozzles

Pressure-activated, automatic shut-off nozzle for full-service and self-service stations.

- XS[®] MFM nozzle shuts off when:
 - the pump shuts off.
 - the gas tank is full.
 - the lever is opened before the pump is turned on.
 - the leak detector has not completed the test cycle.
- Stainless steel reinforced spout bushing keeps spout tip round, and acts as a captive fastener to prevent tip-end sensor damage.
- Nozzle is equipped with a unique Flo-Stop[®] device that shuts off the nozzle if it falls from the fill neck or raises above the horizontal.
- *StreamShaper*[®] reduces turbulence for straighter fuel flow and less splash back spillage.
- Comes standard with smooth full grip guard.
- Tilt poppet design provides precise “to-the-penny” dispensing.
- Optional sightglass provides a clear window for the customer to view the fuel as it passes through the main poppet valve.
- Optional cold weather seals are rated to -40° F/C.
- Optional Gilbarco, Tokheim, and Wayne handguards can be fitted with a magnet to trigger the dispenser’s proximity switch, or can be provided without the magnet for dispensers equipped with a standard “flapper” switch.
- Optional Flo-Equalizer[®] prohibits the nozzle from exceeding 10 gpm (37.9 Lpm).
- Optional Drip Less spout mitigates the amount of fuel released from the spout tip after refueling is completed.
- ADA-compliant EZ Lever reduces the force required to open the main poppet valve by 50%, resulting in a lever operating force ≤5 lbs.



MODEL NO.
159562

New Unleaded Nozzles with NPT Inlet

MODEL NO.	DESCRIPTION	SHIPPING WEIGHT LBS (KG)
159562	with Two Notch Hold Open Clip and 1808 Waffle Splash Guard	3.3 (1.5)
498162	with Two Notch Hold Open Clip, 1808 Waffle Splash Guard and Cold Weather Seals	3.3 (1.5)

^ NOT LISTED

New Light Duty Diesel Nozzles with NPT Inlet

MODEL NO.	DESCRIPTION	SHIPPING WEIGHT LBS (KG)
159560	with Two Notch Hold Open Clip and 1808 Waffle Splash Guard	3.3 (1.5)
1595267	with Two Notch Hold Open Clip, 1808 Waffle Splash Guard and Drip Less Spout	3.3(1.5)
E159560	with Two Notch Hold Open Clip, Mate Guard, Polymer Handle Cover and 1808 Waffle Splash Guard	3.3(1.5)

^ NOT LISTED

New Unleaded Nozzles with M34 Inlet

MODEL NO.	DESCRIPTION	SHIPPING WEIGHT LBS (KG)
E1595293N [^]	with Two Notch Hold Open Clip, Mate Guard, Polymer Handle Cover and 1808 Waffle Splash Guard	3.3(1.5)
E15230293N [^]	with Two Notch Hold Open Clip, Wayne Magnetic Handguard, Mate Guard, Polymer Handle Cover and 1808 Waffle Splash Guard	3.3(1.5)
E15230298N [^]	with Two Notch Hold Open Clip, Wayne Magnetic Handguard, Mate Guard and Polymer Handle Cover	3.3(1.5)

^ NOT LISTED

New Light Duty Diesel Nozzles with M34 Inlet

MODEL NO.	DESCRIPTION	SHIPPING WEIGHT LBS (KG)
E1525297N [^]	with Two Notch Hold Open Clip, Mate Guard, Polymer Handle Cover and 1808 Waffle Splash Guard	3.3(1.5)
E15230297 [^]	with Two Notch Hold Open Clip, Wayne Magnetic Handguard, Mate Guard and Polymer Handle Cover	3.3(1.5)

^ NOT LISTED



II 1 G
EN 13012
TYPE 1



P-TÜ7-8113626964

WARNING: Cancer and Reproductive Harm - www.P65Warnings.ca.gov

XS[®] MFM Nozzles

Pressure-activated, automatic shut-off nozzle for full-service and self-service stations.

Dimensions

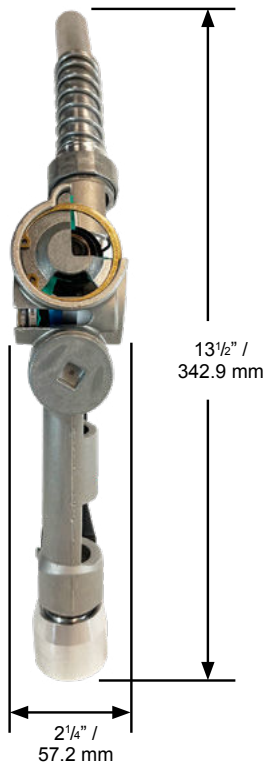

Construction

Body	Die cast aluminum body with high-impact polymer handguard and permanently-secured, machined aluminum inlet adapter
Seals	Fluorocarbon
Packing	Double o-ring seal protected by fiber-reinforced Teflon®
Lever	Two piece polymer EZ Lever
Inlet	1" (25.4 mm) NPT, 1" (25.4 mm) BSP or M34

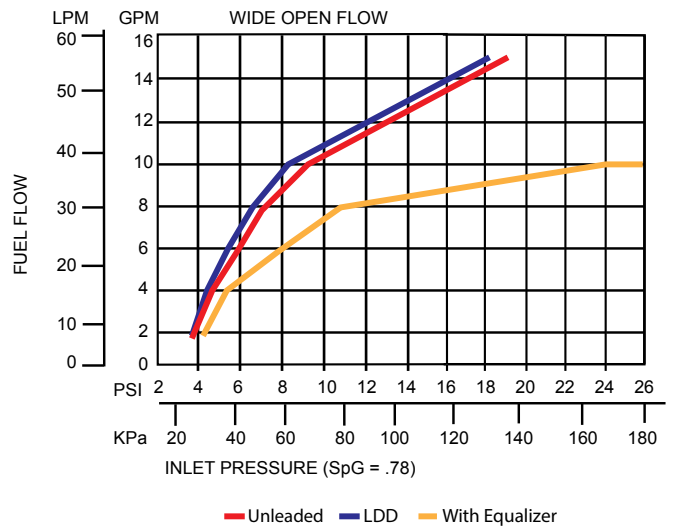

XS[®] MFM Nozzles

CONVENTIONAL FUELLING

Pressure-activated, automatic shut-off nozzle for full-service and self-service stations.

Nozzle Options

Nozzle Guard Options



Full Grip Guard

POPD[®]S
Full Grip Guard

POPD[®]H
Full Grip Guard

Mate Guard

POPD[®]S
Mate Guard

POPD[®]H
Mate Guard

Waffle Guard Options



1807 Waffle Guard



1808 Waffle Guard

Handguard Options



Standard Polymer
Handguard

Gilbarco Polymer
Handguard
(with or without Magnet)

Tokheim Polymer
Handguard
(with or without Magnet)

Wayne Polymer
Handguard
(with or without Magnet)

Latch Plate Options

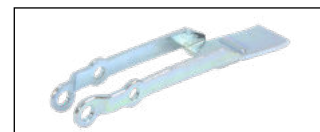

1 - Position Latch Plate

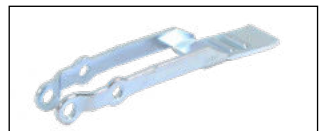

2 - Position Latch Plate

Lever Options



Lever without Hold
Open Clip



Lever with Hold
Open Clip

Flo-Equalizer[®] Option

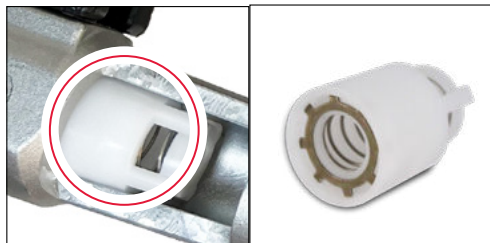

Sightglass Option



XS[®] MFM Nozzles

Pressure-activated, automatic shut-off nozzle for full-service and self-service stations.

System Options

Safe-T-Breaks[®]

MODEL NO.	DESCRIPTION
002276	1" F x 1" F NPT Reconnectable Safe-T-Break [®]
003076	1" F x 1" F BSPP Reconnectable Safe-T-Break [®]
003076A	1" F x 1" F BSPP Reconnectable Safe-T-Break [®] - Atex
005231	1" F x 1" F Low Pull NPT Reconnectable Safe-T-Break [®]
005812	1" F x 1" F NPT Non-Reconnectable Safe-T-Break [®]
006301	1" F x 1" F NPT Non-Reconnectable PCC Safe-T-Break [®]
006914	1" F x 1" F BSPP Non-Reconnectable Safe-T-Break [®]
008331	3/4" F x 3/4" F NPT CK Reconnectable MAGBREAK [®]
009911	3/4" F x 3/4" F BSPP Reconnectable G2 MAGBREAK [®]

Swivel/Safe-T-Break[®] Combos

MODEL NO.	DESCRIPTION
005969	1" M NPT Multi-Plane Swivel connected to 1" F NPT Reconnectable Safe-T-Break [®]
008015	1" M BSPP Multi-Plane Swivel connected to 1" F BSPP Reconnectable Safe-T-Break [®]
008015A	1" M BSPP Multi-Plane Swivel connected to 1" F BSPP Reconnectable Safe-T-Break [®] - Atex

Spouts

MODEL NO.	DESCRIPTION
001471	Light Duty Diesel Spout
001473	Unleaded Spout
010353	Light Duty Diesel Long Spout
010434	Unleaded Long Spout

Pressure/Vacuum Vents

MODEL NO.	DESCRIPTION
004620	2" Slip-On Pressure Vacuum Vent
004885	2" Thread-On Pressure Vacuum Vent - NPT
005885	2" Thread-On Pressure Vacuum Vent with Internal Screen - NPT

Accessories, Testing and Maintenance

MODEL NO.	DESCRIPTION
000397	Unleaded Spout Gauge
003593	Hold Open Clip Kit
004490	Conventional Flo-Equalizer [®] - 10 gpm / 37.9 Lpm
007089	Nozzle Service Kit
007490	Internal Flo-Equalizer [®] - 10 gpm / 37.9 Lpm

















Swivels

MODEL NO.	DESCRIPTION
000087	1" M x 1" F NPT Multi-Plane Swivel
000095	1" M x 1" F NPT 70° Multi-Plane Swivel
003306	1" M x 1" F BSPP Multi-Plane Swivel
003395	1" M x 1" F NPT Multi-Plane Restricted Swivel
004860	1" M x 1" F NPT Multi-Plane High Volume Swivel
006949	1" M x 1" F BSPP Multi-Plane High Volume Swivel

Guards

MODEL NO.	DESCRIPTION
001506	Protection Package
001806	Full Grip Reguard
001807	Waffle Splash Guard with Small Hole
001808	Waffle Splash Guard
001809	Reguard Protection Package
003440	Mate Easy-On Package
003795	Mate Guard
004145	Full Grip Guard
006628	POPD [®] S Clear Cover
006665	POPD [®] S Full Grip Guard
007205	POPD [®] S Full Grip Reguard
007361	Black Handle Cover
007999	POPD [®] H Clear Cover
008165	POPD [®] S Mate Guard
008166	POPD [®] H Mate Guard
008175	POPD [®] EZS Nozzle Guard
008176	POPD [®] EZH Nozzle Guard
008185	POPD [®] H Full Grip Guard
008192	POPD [®] H Full Grip Reguard
014524	International Mate Package
014530	International Mate Guard
015247	International POPD [®] H Mate Guard
015253	International POPD [®] H Mate Package

Guard Color Chart

COLOR	SUFFIX	COLOR	SUFFIX	COLOR <i>CUSTOM</i>	SUFFIX
	-01		-08		-07 <i>CUSTOM</i>
	-02		-09		-18 <i>CUSTOM</i>
	-03		-16		-19 <i>CUSTOM</i>
	-04		-21		-20 <i>CUSTOM</i>
	-05		-39		-22 <i>CUSTOM</i>
	-06				

Scuff Guards are to be ordered with the corresponding guard color option added to the model number. Example: If BLUE guards are desired, add guard color option -01 to the model number (159504-01). For custom colors, a minimum order of 4,000 guards will be required.

X Nozzles

CONVENTIONAL FUELLING

Automatic shut-off nozzle for full-service and self-service stations.

- X nozzle shuts off when the gas tank is full.
- Stainless steel reinforced spout bushing keeps spout tip round, and acts as a captive fastener to prevent tip-end sensor damage.
- Nozzle is equipped with a unique Flo-Stop® device that shuts off the nozzle if it falls from the fill neck or raises above the horizontal.
- StreamShaper® reduces turbulence for straighter fuel flow and less splash back spillage.
- Comes standard with smooth full grip guard.
- Tilt poppet design provides precise “to-the-penny” dispensing.
- Optional cold weather seals are rated to -40° F/C.
- Optional sightglass provides a clear window for the customer to view the fuel as it passes through the main poppet valve.
- Optional Gilbarco, Tokheim, and Wayne handguards can be fitted with a magnet to trigger the dispenser’s proximity switch, or can be provided without the magnet for dispensers equipped with a standard “flapper” switch.
- Optional Flo-Equalizer® prohibits the nozzle from exceeding 10 gpm (37.9 Lpm).
- ADA-compliant EZ Lever reduces the force required to open the main poppet valve by 50%, resulting in a lever operating force ≤5 lbs.



MODEL NO.
159408

New Unleaded Nozzles with NPT Inlet

MODEL NO.	DESCRIPTION	SHIPPING WEIGHT LBS (KG)
159408	without Hold Open Clip	2.9 (1.3)
159468	without Hold Open Clip, with 1808 Waffle Splash Guard	3.0 (1.4)
498408	without Hold Open Clip, with Cold Weather Seals	2.9 (1.3)
498466	without Hold Open Clip, with 1808 Waffle Splash Guard and Cold Weather Seals	3.0 (1.4)
159404N^	with Two Notch Hold Open Clip	2.9 (1.3)
159404NR^	with Two Notch Hold Open Clip and Retail Packaging	2.9 (1.3)
159443N^	with Single Notch Hold Open Clip	2.9 (1.3)
159454N^	with Two Notch Hold Open Clip and Flo-Equalizer®	3.0 (1.4)
159459N^	with Two Notch Hold Open Clip and 1808 Waffle Splash Guard	3.0 (1.4)
159494N^	with Two Notch Hold Open Clip, POPD®S Full Grip Guard and 1808 Waffle Splash Guard	3.0 (1.4)
498404N^	with Two Notch Hold Open Clip and Cold Weather Seals	2.9 (1.3)
1400204N^	with Two Notch Hold Open Clip and Tokheim Magnetic Handguard	3.0 (1.4)
4984108	without Hold Open Clip, with POPD®S Full Grip Guard with 1808 Waffle Splash Guard, with Cold Weather Seals	3.0 (1.4)
E159404N^	with Two Notch Hold Open Clip, Mate Guard and Polymer Handle Cover	2.9 (1.3)
E1503004N^	with Two Notch Hold Open Clip, Wayne Magnetic Handguard, Mate Guard and Polymer Handle Cover	3.0 (1.4)
E159408	without Hold Open Clip with Mate Guard	2.9 (1.3)

^ NOT LISTED

New Unleaded Nozzles with BSP Inlet

MODEL NO.	DESCRIPTION	SHIPPING WEIGHT LBS (KG)
159416N^	with Two Notch Hold Open Clip	2.9 (1.3)
E159420N	without Hold Open Clip, with Mate Guard	2.9 (1.3)
1400216N^	with Two Notch Hold Open Clip and Tokheim Magnetic Handguard	3.0 (1.4)
E159416N^	with Two Notch Hold Open Clip, Mate Guard and Polymer Handle Cover	2.9 (1.3)
E1594165N	with Hold Open Clip, Mate Guard and 1808 Waffle Splash Guard	3.0 (1.4)

^ NOT LISTED



II 1 G
EN 13012
TYPE 1



P-TÜ7-8113626964

WARNING: Cancer and Reproductive Harm - www.P65Warnings.ca.gov

X Nozzles

Automatic shut-off nozzle for full-service and self-service stations.

Dimensions

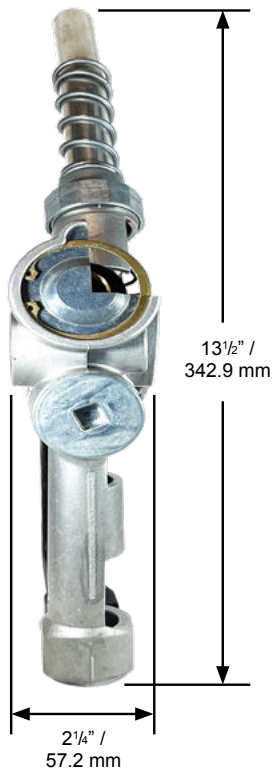
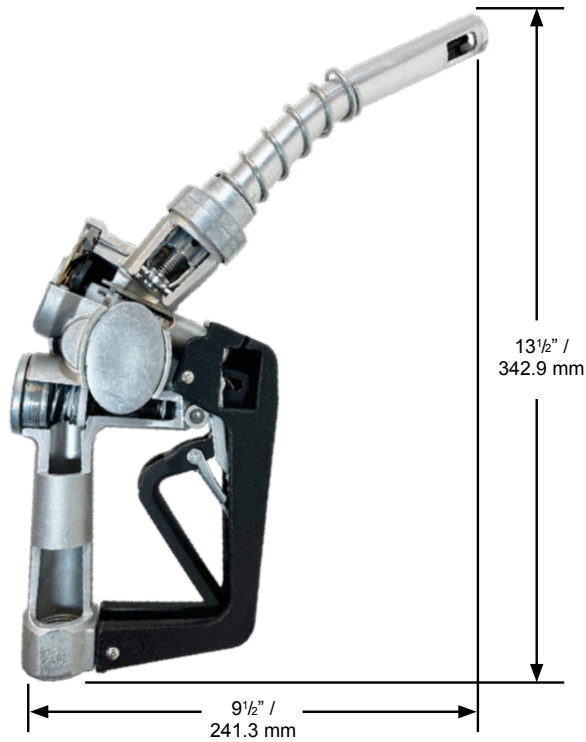

New Light Duty Diesel Nozzles with NPT Inlet

MODEL NO.	DESCRIPTION	SHIPPING WEIGHT LBS (KG)
159407	without Hold Open Clip	2.9 (1.3)
498407	without Hold Open Clip, with Cold Weather Seals	2.9 (1.3)
159403N^	with Two Notch Hold Open Clip	2.9 (1.3)
159463N^	with Two Notch Hold Open Clip and 1808 Waffle Splash Guard	3.0 (1.4)
498403N^	with Two Notch Hold Open Clip and Cold Weather Seals	2.9 (1.3)
4984109	without Hold Open Clip, with POPD®S Full Grip Guard with 1808 Waffle Splash Guard, with Cold Weather Seals	2.9 (1.3)
1400203N	with Two Notch Hold Open Clip and Tokheim Magnetic Handguard	3.0 (1.4)

^ NOT LISTED

New Light Duty Diesel Nozzles with BSP Inlet

MODEL NO.	DESCRIPTION	SHIPPING WEIGHT LBS (KG)
159415N^	with Two Notch Hold Open Clip	2.9 (1.3)
E159415N^	with Two Notch Hold Open Clip, Mate Guard and Polymer Handle Cover	2.9 (1.3)
E1400215N	with Two Notch Hold Open Clip, Tokheim Polymer Handguard, Mate Guard and Polymer Handle Cover	3.0 (1.4)

^ NOT LISTED

Construction

Body	One piece die cast aluminum with high-impact polymer handguard
Seals	Fluorocarbon
Packing	Double o-ring seal protected by fiber-reinforced Teflon®
Lever	Two piece polymer EZ lever
Inlet	3/4" (19 mm) NPT or 3/4" (19 mm) BSP

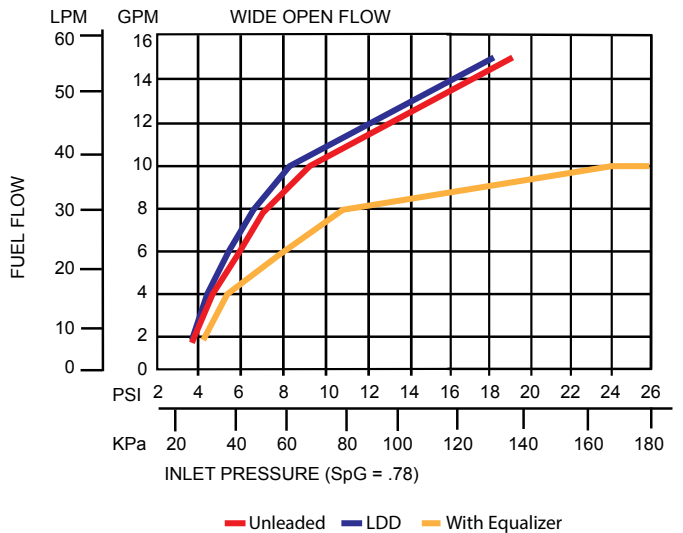

X Nozzles

CONVENTIONAL FUELLING

Automatic shut-off nozzle for full-service and self-service stations.

Nozzle Options

Nozzle Guard Options



Full Grip Guard

POPD®S Full Grip Guard

POPD®H Full Grip Guard

Mate Guard

POPD®S Mate Guard

POPD®H Mate Guard

Waffle Guard Options



1807 Waffle Guard



1808 Waffle Guard

Handguard Options



Standard Polymer Handguard

Gilbarco Polymer Handguard (with or without Magnet)

Tokheim Polymer Handguard (with or without Magnet)

Wayne Polymer Handguard (with or without Magnet)

Latch Plate Options

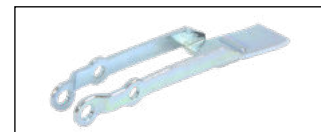

1 - Position Latch Plate

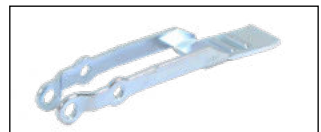

2 - Position Latch Plate

Lever Options



Lever without Hold Open Clip



Lever with Hold Open Clip

Flo-Equalizer® Option



Sightglass Option



X Nozzles

Automatic shut-off nozzle for full-service and self-service stations.

System Options

Safe-T-Breaks®

MODEL NO.	DESCRIPTION
002273	3/4" F x 3/4" F NPT Non-Reconnectable Safe-T-Break®
002774	3/4" F x 3/4" F BSPP Non-Reconnectable Safe-T-Break®
003360	3/4" F x 3/4" F NPT Reconnectable Safe-T-Break®
003385	3/4" F x 3/4" F BSPP Reconnectable Safe-T-Break®
005230	3/4" F x 3/4" F NPT Low Pull Reconnectable Safe-T-Break®
006130	3/4" F x 3/4" F NPT Non-Reconnectable PCC Safe-T-Break®
008330	3/4" F x 3/4" F NPT Reconnectable MAGBREAK®
009910	3/4" F x 3/4" F BSPP Reconnectable MAGBREAK®
010328	3/4" F x 3/4" F NPT Reconnectable High Pull MAGBREAK®
010330	3/4" F x 3/4" F BSPP Reconnectable High Pull MAGBREAK®
002774A	3/4" F x 3/4" F BSPP Non-Reconnectable Safe-T-Break® - Atex
003385A	3/4" F x 3/4" F BSPP Reconnectable Safe-T-Break® - Atex

Swivel/Safe-T-Break® Combos

MODEL NO.	DESCRIPTION
006310	3/4" M NPT Multi-Plane Swivel connected to 3/4" F NPT Reconnectable Safe-T-Break®
007085	3/4" M BSPP Multi-Plane Swivel connected to 3/4" F BSPP Reconnectable Safe-T-Break®
007085A	3/4" M BSPP Multi-Plane Swivel connected to 3/4" F BSPP Reconnectable Safe-T-Break® - Atex

Spouts

MODEL NO.	DESCRIPTION
001471	Light Duty Diesel Spout
001473	Unleaded Spout
010353	Light Duty Diesel Long Spout
010434	Unleaded Long Spout

Pressure/Vacuum Vents

MODEL NO.	DESCRIPTION
004620	2" Slip-On Pressure Vacuum Vent
004885	2" Thread-On Pressure Vacuum Vent - NPT
005885	2" Thread-On Pressure Vacuum Vent with Internal Screen - NPT

Accessories, Testing and Maintenance

MODEL NO.	DESCRIPTION
000397	Unleaded Spout Gauge
003593	Hold Open Clip Kit
004490	Conventional Flo-Equalizer® - 10 gpm / 37.9 Lpm
007089	Nozzle Service Kit
007490	Internal Flo-Equalizer® - 10 gpm / 37.9 Lpm

Swivels

MODEL NO.	DESCRIPTION
000350	3/4" M x 3/4" F NPT Multi-Plane Swivel
000355	3/4" M x 3/4" F NPT Multi-Plane Swivel Anodized Black
002272	3/4" M x 3/4" F NPT 90° Pump Swivel
002771	3/4" M x 3/4" F BSPP 90° Pump Swivel
002950	3/4" M x 3/4" F NPT Multi-Plane Restricted Swivel
003590	3/4" M x 3/4" F BSPP Multi-Plane Swivel
003895	3/4" M x 3/4" F NPT Inline Swivel
002771A	3/4" M x 3/4" F BSPP 90° Pump Swivel - Atex
003590A	3/4" M x 3/4" F BSPP Multi-Plane Swivel - Atex

Guards

MODEL NO.	DESCRIPTION
001506	Protection Package
001806	Full Grip Reguard
001807	Waffle Splash Guard with Small Hole
001808	Waffle Splash Guard
001809	Reguard Protection Package
003440	Mate Easy-On Package
003795	Mate Guard
004145	Full Grip Guard
006628	POPD® S Clear Cover
006665	POPD® S Full Grip Guard
007205	POPD® S Full Grip Reguard
007361	Black Handle Cover
007999	POPD® H Clear Cover
008165	POPD® S Mate Guard
008166	POPD® H Mate Guard
008175	POPD® EZS Nozzle Guard
008176	POPD® EZH Nozzle Guard
008185	POPD® H Full Grip Guard
008192	POPD® H Full Grip Reguard
014524	International Mate Package
014530	International Mate Guard
015247	International POPD® H Mate Guard
015253	International POPD® H Mate Package

Guard Color Chart

COLOR	SUFFIX	COLOR	SUFFIX	COLOR <small>CUSTOM</small>	SUFFIX
Blue	-01	Gold	-08	Amoco Blue	-07 <small>CUSTOM</small>
Red	-02	Silver	-09	Apple Green	-18 <small>CUSTOM</small>
Green	-03	BP Green	-16	Purple	-19 <small>CUSTOM</small>
Black	-04	M Blue	-21	Pink	-20 <small>CUSTOM</small>
Yellow	-05	Orange	-39	BPS Green	-22 <small>CUSTOM</small>
White	-06				

Scuff Guards are to be ordered with the corresponding guard color option added to the model number. Example: If BLUE guards are desired, add guard color option -01 to the model number (159504-01). For custom colors, a minimum order of 4,000 guards will be required.

1A Nozzles

Automatic shut-off nozzle for full-service and self-service stations.

- 1A nozzle shuts off when the gas tank is full.
- Stainless steel reinforced spout bushing keeps spout tip round, and acts as a captive fastener to prevent tip-end sensor damage.
- Nozzle is equipped with a unique Flo-Stop® device the shuts off the nozzle if it falls from the fill neck or raises above the horizontal.
- StreamShaper® reduces turbulence for straighter fuel flow and less splash back spillage.
- Comes standard with smooth full grip guard.
- Optional tilt poppet design provides precise “to-the-penny” dispensing.
- Optional cold weather seals are rated to -40 °F/C.
- Optional Gilbarco, Tokheim, and Wayne handguards can be fitted with a magnet to trigger the dispenser’s proximity switch, or can be provided without the magnet for dispensers equipped with a standard “flapper” switch.
- ADA-compliant EZ Lever reduces the force required to open the main poppet valve by 50%, resulting in a lever operating force ≤5 lbs.



MODEL NO.
209808

New Unleaded PHG Nozzles with NPT Inlet

MODEL NO.	DESCRIPTION	SHIPPING WEIGHT LBS (KG)
209808	without Hold Open Clip, with Polymer Handguard	3.3 (1.4)
209866	without Hold Open Clip, with Polymer Handguard and 1808 Waffle Splash Guard	3.4 (1.5)
209804N^	with Two Notch Hold Open Clip and Polymer Handguard	3.3 (1.4)
209859N^	with Two Notch Hold Open Clip, Polymer Handguard and 1808 Waffle Splash Guard	3.4 (1.5)
209872N^	with Two Notch Hold Open Clip, Polymer Handguard, 1808 Waffle Splash Guard and 385 Reducer Bushing	3.5 (1.6)

^ NOT LISTED

New Unleaded PHG Nozzles with BSP Inlet

MODEL NO.	DESCRIPTION	SHIPPING WEIGHT LBS (KG)
209816N^	with Two Notch Hold Open Clip and Polymer Handguard	3.5 (1.6)

^ NOT LISTED

New Light Duty Diesel PHG Nozzles with NPT Inlet

MODEL NO.	DESCRIPTION	SHIPPING WEIGHT LBS (KG)
209807	without Hold Open Clip, with Polymer Handguard	3.3 (1.4)
209803N^	with Two Notch Hold Open Clip and Polymer Handguard	3.3 (1.4)
2098208N^	with Two Notch Hold Open Clip, Polymer Handguard and 385 Reducer Bushing	3.4 (1.5)
209861N^	with Two Notch Hold Open Clip, Polymer Handguard and 1808 Waffle Splash Guard	3.5 (1.6)

^ NOT LISTED

New Light Duty Diesel PHG Nozzles with BSP Inlet

MODEL NO.	DESCRIPTION	SHIPPING WEIGHT LBS (KG)
209815N^	with Two Notch Hold Open Clip and Polymer Handguard	3.3 (1.4)
E1064715N^	with Two Notch Hold Open Clip, Polymer Handguard, Mate Guard and Polymer Handle Cover, without UL Spout Groove	3.3 (1.4)

^ NOT LISTED



WARNING: Cancer and Reproductive Harm - www.P65Warnings.ca.gov

1A Nozzles

Automatic shut-off nozzle for full-service and self-service stations.

Dimensions

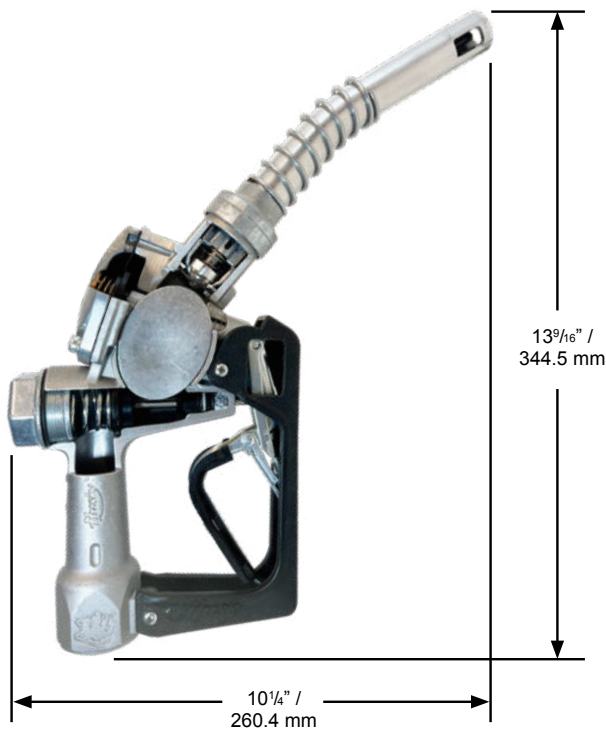

New Unleaded MHG Nozzles with NPT Inlet

696108	without Hold Open Clip, with Metal Handguard	3.5 (1.6)
696104N^	with Two Notch Hold Open Clip and Metal Handguard	3.5 (1.6)
696159N^	with Two Notch Hold Open Clip, Metal Handguard and 1808 Waffle Splash Guard	3.6 (1.6)
696172N^	with Two Notch Hold Open Clip, Metal Handguard, 1808 Waffle Splash Guard and 385 Reducer Bushing	3.7 (1.7)

New Light Duty Diesel MHG Nozzles with NPT Inlet

696103N^	with Two Notch Hold Open Clip and Metal Handguard	3.5 (1.6)
696161N^	with Two Notch Hold Open Clip, Metal Handguard and 1808 Waffle Splash Guard	3.6 (1.6)

^ NOT LISTED

Construction

Body	One piece die cast aluminum with high-impact polymer or metal handguard
Seals	Fluorocarbon
Packing	Double o-ring seal protected by fiber-reinforced Teflon®
Lever	Two-piece polymer EZ Lever
Inlet	1" (25.4 mm) NPT or 1" (25.4 mm) BSP

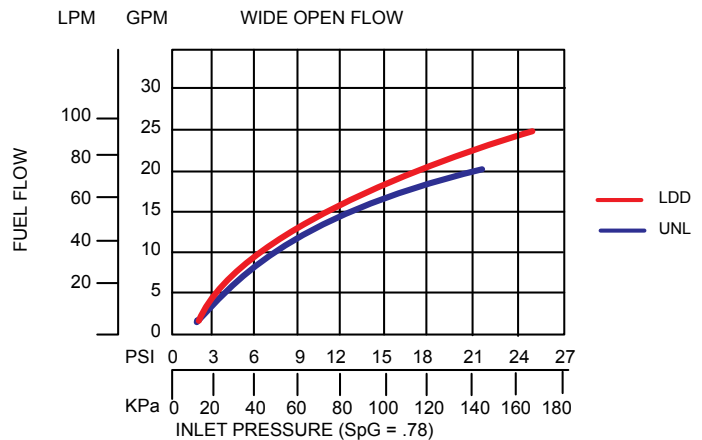

1A Nozzles

CONVENTIONAL FUELLING

Automatic shut-off nozzle for full-service and self-service stations.

Nozzle Options

Nozzle Guard Options



Full Grip Guard

POPD®S Full Grip Guard

POPD®H Full Grip Guard

Mate Guard

POPD®S Mate Guard

POPD®H Mate Guard

Waffle Guard Options



1808 Waffle Guard

Reducer Bushing



000385

Handguard Options



Standard Polymer Handguard

Standard Metal Handguard

Gilbarco Polymer Handguard

Tokheim Polymer Handguard

Wayne Polymer Handguard

(with or without Magnet) (with or without Magnet) (with or without Magnet)

Lever Options

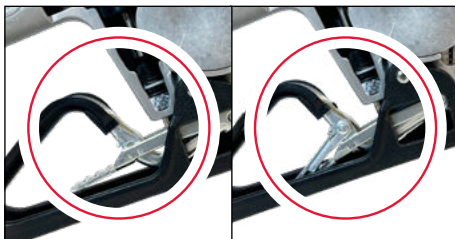

Lever without Hold Open Clip

Lever with Hold Open Clip

Latch Plate Options



1 - Position Latch Plate

2 - Position Latch Plate

1A Nozzles

Automatic shut-off nozzle for full-service and self-service stations.

System Options

Safe-T-Breaks®

MODEL NO.	DESCRIPTION
002276	1" F x 1" F NPT Reconnectable Safe-T-Break®
003076	1" F x 1" F BSPP Reconnectable Safe-T-Break®
003076A	1" F x 1" F BSPP Reconnectable Safe-T-Break® - Atex
005231	1" F x 1" F Low Pull NPT Reconnectable Safe-T-Break®
005812	1" F x 1" F NPT Non-Reconnectable Safe-T-Break®
006301	1" F x 1" F NPT Non-Reconnectable PCC Safe-T-Break®
006914	1" F x 1" F BSPP Non-Reconnectable Safe-T-Break®
008331	1" F x 1" F NPT CK Reconnectable MAGBREAK®
009911	1" F x 1" F BSPP Reconnectable G2 MAGBREAK®

Swivel/Safe-T-Break® Combos

MODEL NO.	DESCRIPTION
005969	1" M NPT Multi-Plane Swivel connected to 1" F NPT Reconnectable Safe-T-Break®
008015	1" M BSPP Multi-Plane Swivel connected to 1" F BSPP Reconnectable Safe-T-Break®
008015A	1" M BSPP Multi-Plane Swivel connected to 1" F BSPP Reconnectable Safe-T-Break® - Atex Spouts

Spouts

MODEL NO.	DESCRIPTION
001471	Light Duty Diesel Spout
001473	Unleaded Spout
010353	Light Duty Diesel Long Spout
010434	Unleaded Long Spout

Pressure/Vacuum Vents

MODEL NO.	DESCRIPTION
004620	2" Slip-On Pressure Vacuum Vent
004885	2" Thread-On Pressure Vacuum Vent - NPT
005885	2" Thread-On Pressure Vacuum Vent with Internal Screen - NPT

Accessories, Testing and Maintenance

MODEL NO.	DESCRIPTION
000385	1" M x 3/4" F Reducer Bushing
000397	Unleaded Spout Gauge
003593	Hold Open Clip Kit
007089	Nozzle Service Kit

Swivels

MODEL NO.	DESCRIPTION
000087	1" M x 1" F NPT Multi-Plane Swivel
000095	1" M x 1" F NPT 70° Multi-Plane Swivel
000352	1" M x 3/4" F NPT Multi-Plane Swivel
000356	1" M x 3/4" F NPT Multi-Plane Swivel Anodized Black
003306	1" M x 1" F BSPP Multi-Plane Swivel
003306A	1" M x 1" F BSPP Multi-Plane Swivel - Atex
003395	1" M x 1" F NPT Multi-Plane Restricted Swivel
004860	1" M x 1" F NPT Multi-Plane High Volume Swivel
006949	1" M x 1" F BSPP Multi-Plane High Volume Swivel

Guards

MODEL NO.	DESCRIPTION
000099	Protection Package
000226	Mate Nozzle Guard
000554	Full Grip Guard
001804	Full Grip Reguard
001808	Waffle Splash Guard
001811	Reguard Protection Package
005494	Lever Guard
006628	POPD® S Clear Cover
001808	Protection Package
006655	POPD® S Full Grip Guard
007210	POPD® S Full Grip Reguard
007999	POPD® H Clear Cover
008169	POPD® S Mate Nozzle Guard
008170	POPD® H Mate Nozzle Guard
008179	POPD® EZS Nozzle Guard
008180	POPD® EZH Nozzle Guard
008183	POPD® H Full Grip Guard
008190	POPD® H Full Grip Reguard

Guard Color Chart

COLOR	SUFFIX	COLOR	SUFFIX	COLOR <i>CUSTOM</i>	SUFFIX
Blue	-01	Gold	-08	Amoco Blue	-07 <i>CUSTOM</i>
Red	-02	Silver	-09	Apple Green	-18 <i>CUSTOM</i>
Green	-03	BP Green	-16	Purple	-19 <i>CUSTOM</i>
Black	-04	M Blue	-21	Pink	-20 <i>CUSTOM</i>
Yellow	-05	Orange	-39	BPS Green	-22 <i>CUSTOM</i>
White	-06				

Scuff Guards are to be ordered with the corresponding guard color option added to the model number. Example: If BLUE guards are desired, add guard color option -01 to the model number (159504-01). For custom colors, a minimum order of 4,000 guards will be required.

1AS Nozzles

Pressure-activated, automatic shut-off nozzle for full-service and self-service stations.

- 1AS nozzle shuts off when:
 - the pump shuts off.
 - the gas tank is full.
 - the lever is opened before the pump is turned on.
 - the leak detector has not completed the test cycle.
- Optional tilt poppet design provides precise “to-the-penny” dispensing.
- Optional cold weather seals are rated to -40° F/C.
- Optional Gilbarco, Tokheim, and Wayne handguards can be fitted with a magnet to trigger the dispenser’s proximity switch, or can be provided without the magnet for dispensers equipped with a standard “flapper” switch.
- ADA-compliant EZ Lever reduces the force required to open the main poppet valve by 50%, resulting in a lever operating force ≤5 lbs.
- Stainless steel reinforced spout bushing keeps spout tip round, and acts as a captive fastener to prevent tip-end sensor damage.
- Nozzle is equipped with a unique Flo-Stop® device that shuts off the nozzle if it falls from the fill neck or raises above the horizontal.
- StreamShaper® reduces turbulence for straighter fuel flow and less splash back spillage.
- Comes standard with smooth full grip guard.

New Unleaded PHG Nozzles with NPT Inlet

MODEL NO.	DESCRIPTION	SHIPPING WEIGHT LBS (KG)
1215904	with Two Notch Hold Open Clip and Polymer Handguard	3.3 (1.4)
12159209	with Two Notch Hold Open Clip, Polymer Handguard and 385 Reducer Bushing	3.4 (1.5)

New Light Duty Diesel PHG Nozzles with NPT Inlet

MODEL NO.	DESCRIPTION	SHIPPING WEIGHT LBS (KG)
1215903	with Two Notch Hold Open Clip and Polymer Handguard	3.3 (1.4)
1215961	with Two Notch Hold Open Clip, Polymer Handguard and 1808 Waffle Splash Guard	3.4 (1.5)
1398903	with Two Notch Hold Open Clip, Polymer Handguard and Cold Weather Seals	3.3 (1.4)
12159208	with Two Notch Hold Open Clip, Polymer Handguard and 385 Reducer Bushing	3.4 (1.5)
E1215903	with Two Notch Hold Open Clip, Polymer Handguard, Mate Guard and Polymer Handle Cover	3.3 (1.4)
12159263A*	with Two Notch Hold Open Clip, Polymer Handguard, 1808 Waffle Splash Guard and Inlet Screen, Atex	3.4 (1.5)
1215903N^	with Two Notch Hold Open Clip and Polymer Handguard	3.3 (1.4)
1691103N^	with Two Notch Hold Open Clip, Polymer Handguard, 1808 Waffle Splash Guard and Cold Weather Seals	3.3 (1.4)

New Light Duty Diesel PHG Nozzles with M34 Inlet

MODEL NO.	DESCRIPTION	SHIPPING WEIGHT LBS (KG)
E12159294N^	with Two Notch Hold Open Clip and Polymer Handguard	3.3 (1.4)

^ NOT LISTED



MODEL NO.
1215904



WARNING: Cancer and Reproductive Harm - www.P65Warnings.ca.gov

1AS Nozzles

Pressure-activated, automatic shut-off nozzle for full-service and self-service stations.

Dimensions

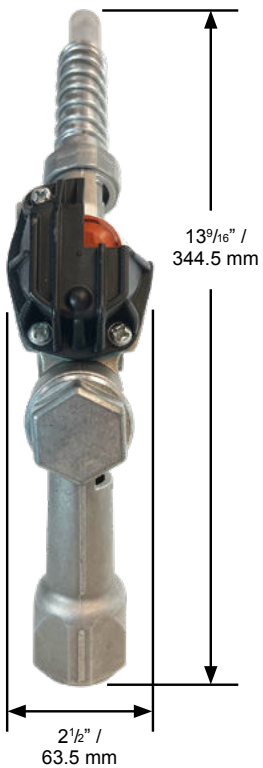
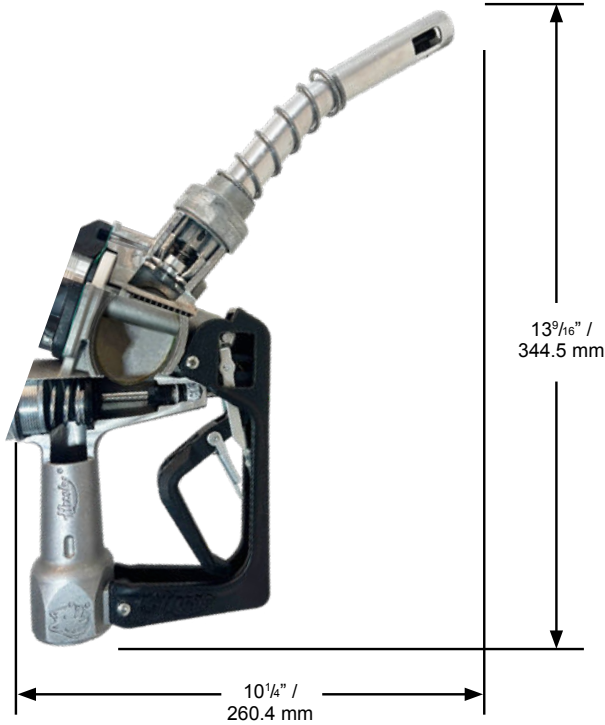

New Unleaded MHG Nozzles with NPT Inlet

MODEL NO.	DESCRIPTION	SHIPPING WEIGHT LBS (KG)
1216204	with Two Notch Hold Open Clip and Metal Handguard	3.5 (1.6)

New Light Duty Diesel MHG Nozzles with NPT Inlet

MODEL NO.	DESCRIPTION	SHIPPING WEIGHT LBS (KG)
1216203	with Two Notch Hold Open Clip and Metal Handguard	3.5 (1.6)
1399203	with Two Notch Hold Open Clip, Metal Handguard and Cold Weather Seals	3.5 (1.6)

New Light Duty Diesel MHG Nozzles with M34 Inlet

MODEL NO.	DESCRIPTION	SHIPPING WEIGHT LBS (KG)
E16576294N^	with Two Notch Hold Open Clip, Metal Handguard and Cold Weather Seals	3.5 (1.6)

Construction

Body	One piece die cast aluminum with high-impact polymer or metal handguard
Seals	Fluorocarbon
Packing	Double o-ring seal protected by fiber-reinforced Teflon®
Lever	Two piece polymer EZ Lever
Inlet	1" (25.4 mm) NPT, 1" (25.4 mm) BSP or M34 x 1.5 mm

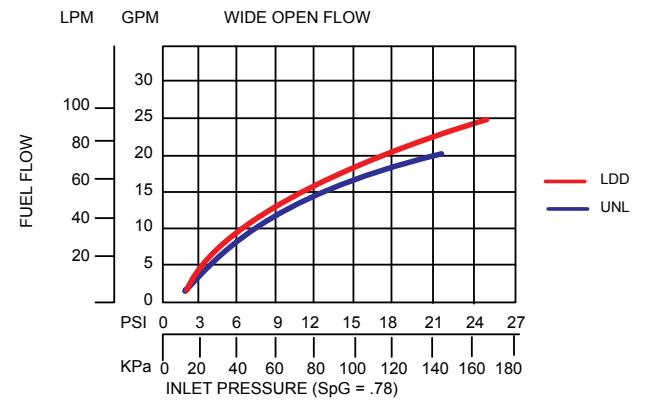

1AS Nozzles

Pressure-activated, automatic shut-off nozzle for full-service and self-service stations.

Nozzle Options

Nozzle Guard Options



Full Grip Guard

POPD®S Full Grip Guard

POPD®H Full Grip Guard

Mate Guard

POPD®S Mate Guard

POPD®H Mate Guard

Waffle Guard Options



1808 Waffle Guard

Reducer Bushing



000385

Handguard Options



Standard Polymer Handguard

Standard Metal Handguard

Gilbarco Polymer Handguard

(with or without Magnet)

Tokheim Polymer Handguard

(with or without Magnet)

Wayne Polymer Handguard

(with or without Magnet)

Lever Options

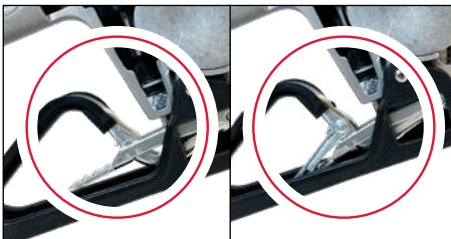

Lever without Hold Open Clip

Lever with Hold Open Clip

Latch Plate Options

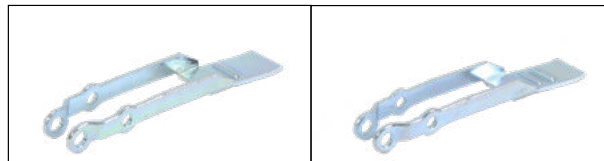

1 - Position Latch Plate

2 - Position Latch Plate

1AS Nozzles

Pressure-activated, automatic shut-off nozzle for full-service and self-service stations.

System Options

Safe-T-Breaks®

MODEL NO.	DESCRIPTION
002276	1" F x 1" F NPT Reconnectable Safe-T-Break®
003076	1" F x 1" F BSPP Reconnectable Safe-T-Break®
003076A	1" F x 1" F BSPP Reconnectable Safe-T-Break® - Atex
005231	1" F x 1" F Low Pull NPT Reconnectable Safe-T-Break®
005812	1" F x 1" F NPT Non-Reconnectable Safe-T-Break®
006301	1" F x 1" F NPT Non-Reconnectable PCC Safe-T-Break®
006914	1" F x 1" F BSPP Non-Reconnectable Safe-T-Break®
008331	1" F x 1" F NPT CK Reconnectable MAGBREAK®
009911	1" F x 1" F BSPP Reconnectable G2 MAGBREAK®

Swivel/Safe-T-Break® Combos

MODEL NO.	DESCRIPTION
005969	1" M NPT Multi-Plane Swivel connected to 1" F NPT Reconnectable Safe-T-Break®
008015	1" M BSPP Multi-Plane Swivel connected to 1" F BSPP Reconnectable Safe-T-Break®
008015A	1" M BSPP Multi-Plane Swivel connected to 1" F BSPP Reconnectable Safe-T-Break® - Atex Spouts

Spouts

MODEL NO.	DESCRIPTION
001471	Light Duty Diesel Spout
001473	Unleaded Spout
010353	Light Duty Diesel Long Spout
010434	Unleaded Long Spout

Pressure/Vacuum Vents

MODEL NO.	DESCRIPTION
004620	2" Slip-On Pressure Vacuum Vent
004885	2" Thread-On Pressure Vacuum Vent - NPT
005885	2" Thread-On Pressure Vacuum Vent with Internal Screen - NPT

Accessories, Testing and Maintenance

MODEL NO.	DESCRIPTION
000385	1" M x 3/4" F Reducer Bushing
000397	Unleaded Spout Gauge
003593	Hold Open Clip Kit
007089	Nozzle Service Kit

Swivels

MODEL NO.	DESCRIPTION
000087	1" M x 1" F NPT Multi-Plane Swivel
000095	1" M x 1" F NPT 70° Multi-Plane Swivel
000352	1" M x 3/4" F NPT Multi-Plane Swivel
000356	1" M x 3/4" F NPT Multi-Plane Swivel Anodized Black
003306	1" M x 1" F BSPP Multi-Plane Swivel
003306A	1" M x 1" F BSPP Multi-Plane Swivel - Atex
003395	1" M x 1" F NPT Multi-Plane Restricted Swivel
004860	1" M x 1" F NPT Multi-Plane High Volume Swivel
006949	1" M x 1" F BSPP Multi-Plane High Volume Swivel

Guards

MODEL NO.	DESCRIPTION
001807	Waffle Splash Guard with Smaller Hole
001808	Waffle Splash Guard
005494	Lever Guard
012164	Full Grip Guard

Guard Color Chart

COLOR	SUFFIX	COLOR	SUFFIX	COLOR <i>CUSTOM</i>	SUFFIX
Blue	-01	Gold	-08	Amoco Blue	-07 <i>CUSTOM</i>
Red	-02	Silver	-09	Apple Green	-18 <i>CUSTOM</i>
Green	-03	BP Green	-16	Purple	-19 <i>CUSTOM</i>
Black	-04	M Blue	-21	Pink	-20 <i>CUSTOM</i>
Yellow	-05	Orange	-39	BPS Green	-22 <i>CUSTOM</i>
White	-06				

Scuff Guards are to be ordered with the corresponding guard color option added to the model number. Example: If BLUE guards are desired, add guard color option -01 to the model number (159504-01). For custom colors, a minimum order of 4,000 guards will be required.

ECO Nozzles

Automatic shut-off conventional nozzle equipped with mechanical interlock.

- ECO nozzle shuts off when:
 - the gas tank is full.
 - the mechanical interlock is disengaged, or the nozzle falls from the vehicle's fill pipe.
- Nozzle is also equipped with a unique Flo-Stop® device that shuts off the nozzle if it falls from the fill neck or raises above the horizontal for added security.
- Stainless steel reinforced spout bushing keeps spout tip round, and acts as a captive fastener to prevent tip-end sensor damage.
- StreamShaper® reduces turbulence for straighter fuel flow and less splash back spillage.
- Drip Less spout reduces/eliminates drips from spout.
- Lightest insertion "force" of any safety interlock-operated nozzle.
- Aluminum casting with high-impact polymer handguard provides a lightweight, easier to handle conventional nozzle.
- Unique tilt poppet design provides precise "to-the-penny" dispensing.
- Optional cold weather seals are rated to -40° F/C.
- CARB certified per CP-207 for drips, spills, spitting and liquid retention.
- Comes standard with smooth full grip guard.
- ADA-compliant EZ Lever reduces the force required to open the main poppet valve by 50%, resulting in a lever operating force ≤5 lbs.
- All seals are UL approved fluorocarbon compounds to prevent degradation from ethanol blends
- Compatible with unleaded and all ethanol blends through E-25



MODEL NO.
1190404

New Unleaded PHG Nozzles with NPT Inlet

MODEL NO.	DESCRIPTION	SHIPPING WEIGHT LBS (KG)
1190404*	with Two Notch Hold Open Clip	2.8 (1.3)
1190408*	without Hold Open Clip	2.8 (1.3)
1474504	with Two Notch Hold Open Clip and Cold Weather Seals	2.8 (1.3)
11904180*	with Two Notch Hold Open Clip and Flo-Equalizer®	2.8 (1.3)
E1190404*	with Two Notch Hold Open Clip, Mate Guard and Polymer Handle Cover	2.8 (1.3)

New Unleaded Nozzles with BSP Inlet

MODEL NO.	DESCRIPTION	SHIPPING WEIGHT LBS (KG)
E1190416*	with Two Notch Hold Open Clip, Mate Guard and Polymer Handle Cover	2.8 (1.3)
1190416*	with Two Notch Hold Open Clip	2.8 (1.3)

New E25 Nozzles with NPT Inlet

MODEL NO.	DESCRIPTION	SHIPPING WEIGHT LBS (KG)
1708404	with Two Notch Hold Open Clip	2.8 (1.3)
E1708404	with Two Notch Hold Open Clip, Mate Guard and Polymer Handle Cover	2.8 (1.3)



⚠ WARNING: Cancer and Reproductive Harm - www.P65Warnings.ca.gov

ECO Nozzles

Pressure-activated, automatic shut-off nozzle for full-service and self-service stations.

Dimensions

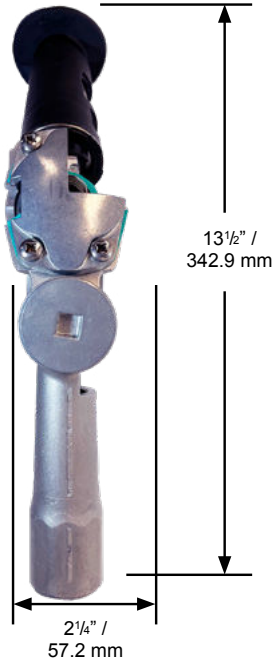
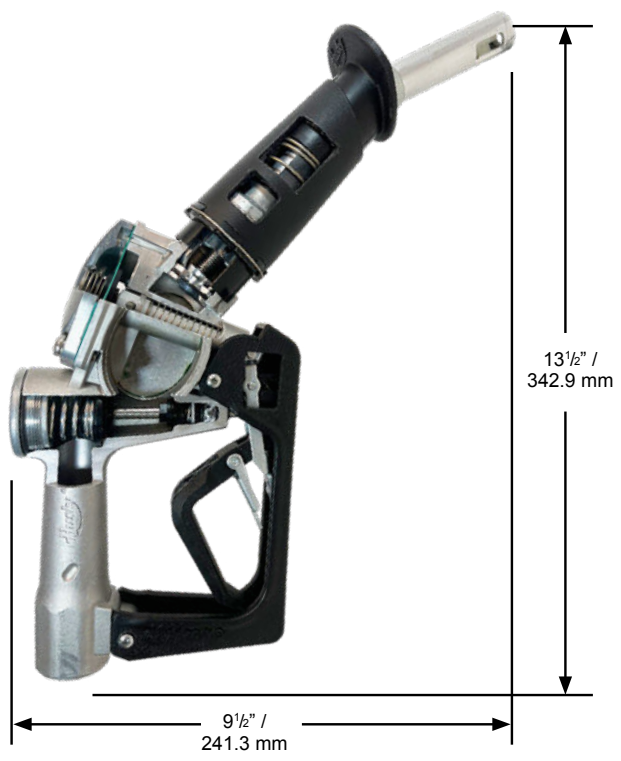

Construction

Body	One piece die cast aluminum with high-impact polymer handguard
Seals	Fluorocarbon
Packing	Double o-ring seal protected by fiber-reinforced Teflon®
Lever	Two piece polymer EZ Lever
Inlet	3/4" (19 mm) NPT or 3/4" (19 mm) BSP

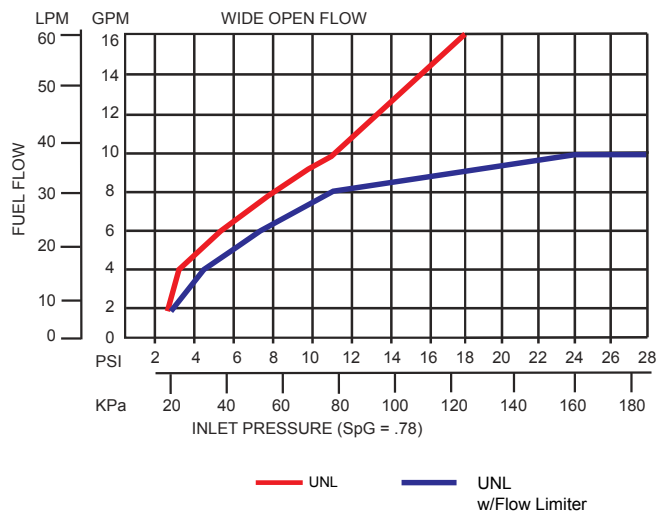

ECO Nozzles

CONVENTIONAL FUELLING

Pressure-activated, automatic shut-off nozzle for full-service and self-service stations.

Nozzle Options

Nozzle Guard Options



Full Grip Guard

POPD®S
Full Grip Guard

POPD®H
Full Grip Guard

Mate Guard

POPD®S
Mate Guard

POPD®H
Mate Guard

Lever Options

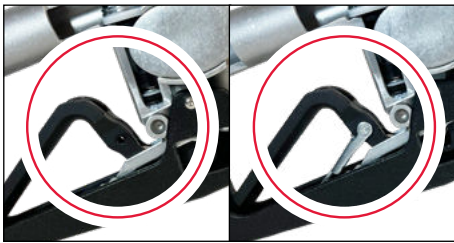

Lever without Hold
Open Clip

Lever with Hold
Open Clip

Flo-Equalizer® Option

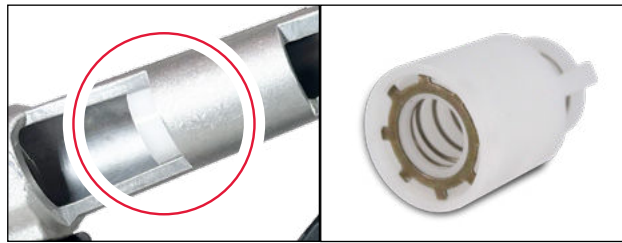

Latch Plate Options

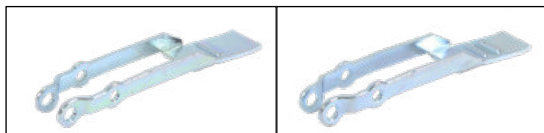

1 - Position Latch Plate

2 - Position Latch Plate

ECO Nozzles

Pressure-activated, automatic shut-off nozzle for full-service and self-service stations.

System Options

Safe-T-Breaks®

MODEL NO.	DESCRIPTION
002273	3/4" F x 3/4" F NPT Non-Reconnectable Safe-T-Break®
002774	3/4" F x 3/4" F BSPP Non-Reconnectable Safe-T-Break®
003360	3/4" F x 3/4" F NPT Reconnectable Safe-T-Break®
003385	3/4" F x 3/4" F BSPP Reconnectable Safe-T-Break®
005230	3/4" F x 3/4" F NPT Low Pull Reconnectable Safe-T-Break®
006130	3/4" F x 3/4" F NPT Non-Reconnectable PCC Safe-T-Break®
008330	3/4" F x 3/4" F NPT Reconnectable MAGBREAK®
009910	3/4" F x 3/4" F BSPP Reconnectable MAGBREAK®
010328	3/4" F x 3/4" F NPT Reconnectable High Pull MAGBREAK®
010330	3/4" F x 3/4" F BSPP Reconnectable High Pull MAGBREAK®
002774A	3/4" F x 3/4" F BSPP Non-Reconnectable Safe-T-Break® - Atex
003385A	3/4" F x 3/4" F BSPP Reconnectable Safe-T-Break® - Atex

Swivel/Safe-T-Break® Combos

MODEL NO.	DESCRIPTION
006310	3/4" M NPT Multi-Plane Swivel connected to 3/4" F NPT Reconnectable Safe-T-Break®
007085	3/4" M BSPP Multi-Plane Swivel connected to 3/4" F BSPP Reconnectable Safe-T-Break®
007085A	3/4" M BSPP Multi-Plane Swivel connected to 3/4" F BSPP Reconnectable Safe-T-Break® - Atex

Spouts

MODEL NO.	DESCRIPTION
013664	Unleaded ECO Spout Assembly Kit

Pressure/Vacuum Vents

MODEL NO.	DESCRIPTION
004620	2" Slip-On Pressure Vacuum Vent
004885	2" Thread-On Pressure Vacuum Vent - NPT
005885	2" Thread-On Pressure Vacuum Vent with Internal Screen - NPT

Accessories, Testing and Maintenance

MODEL NO.	DESCRIPTION
000397	Unleaded Spout Gauge
003593	Hold Open Clip Kit
004490	Conventional Flo-Equalizer® - 10 gpm / 37.9 Lpm
007089	Nozzle Service Kit
007490	Internal Flo-Equalizer® - 10 gpm / 37.9 Lpm

Swivels

MODEL NO.	DESCRIPTION
000350	3/4" M x 3/4" F NPT Multi-Plane Swivel
000355	3/4" M x 3/4" F NPT Multi-Plane Swivel Anodized Black
002272	3/4" M x 3/4" F NPT 90° Pump Swivel
002771	3/4" M x 3/4" F BSPP 90° Pump Swivel
002950	3/4" M x 3/4" F NPT Multi-Plane Restricted Swivel
003590	3/4" M x 3/4" F BSPP Multi-Plane Swivel
003895	3/4" M x 3/4" F NPT Inline Swivel
002771A	3/4" M x 3/4" F BSPP 90° Pump Swivel - Atex
003590A	3/4" M x 3/4" F BSPP Multi-Plane Swivel - Atex

Guards

MODEL NO.	DESCRIPTION
014034	Full Grip Nozzle Guard
016424	Mate Guard
016425	Handle Cover
016423	Mate Guard & Handle Cover Kit

Low Perm Hoses

MODEL NO.	DESCRIPTION
CP12LP8.5	3/4" Low Perm Hardwall 8.5' Assembly Hose
CP12LP8.5SV	3/4" Low Perm Hardwall 8.5' Assembly Hose Swivel
CP12LP9	3/4" Low Perm Hardwall 9' Assembly Hose
CP12LP9SV	3/4" Low Perm Hardwall 9' Assembly Hose Swivel
CP12LP.75	3/4" Low Perm Hardwall 9' Assembly Hose
CP12LP.75SV	3/4" Low Perm Hardwall 9' Assembly Hose Swivel

Guard Color Chart

COLOR	SUFFIX	COLOR	SUFFIX	COLOR <i>CUSTOM</i>	SUFFIX
Blue	-01	Gold	-08	Amoco Blue	-07 <i>CUSTOM</i>
Red	-02	Silver	-09	Apple Green	-18 <i>CUSTOM</i>
Green	-03	BP Green	-16	Purple	-19 <i>CUSTOM</i>
Black	-04	M Blue	-21	Pink	-20 <i>CUSTOM</i>
Yellow	-05	Orange	-39	BPS Green	-22 <i>CUSTOM</i>
White	-06				

Scuff Guards are to be ordered with the corresponding guard color option added to the model number. Example: If BLUE guards are desired, add guard color option -01 to the model number (159504-01). For custom colors, a minimum order of 4,000 guards will be required.



GENERAL FUELING PRODUCTS

Truck & High Volume Nozzles

VIIIS Nozzles

Pressure Activated, automatic shut-off nozzle for truck stop and other high volume full-service, self-service and unattended stations.

- VIIIS nozzle shuts off when:
 - the pump shuts off.
 - the gas tank is full.
 - the lever is opened before the pump is turned on.
 - the leak detector has not completed the test cycle.
- Optional aluminum bushing retains spout spring and keeps spout from rounding-in: the two leading causes of clicking off and splash-back spillage.
- Nozzle is equipped with a unique Flo-Stop® device that shuts off the nozzle if it falls from the fill neck or raises above the horizontal.
- StreamShaper® reduces turbulence for straighter fuel flow and less splash back spillage.
- Strong flow (up to 75 gpm / 283.9 Lpm)
- Dual poppet design equalizes pressure on both sides of the main poppet valve in order to aid in lifting the lever, and ultimately opening the main poppet valve for full flow.
- Optional cold weather seals are rated to -40 °F/C.
- Optional Gilbarco, Tokheim, and Wayne handguards can be fitted with a magnet to trigger the dispenser's proximity switch, or can be provided without the magnet for dispensers equipped with a standard "flapper" switch.
- Comes standard with smooth full grip guard and 1808 waffle splash guard.



MODEL NO.
177610

New High-Flow Diesel PHG Nozzles with NPT Inlet

MODEL NO.	DESCRIPTION	SHIPPING WEIGHT LBS (KG)
177610	with Three Notch Hold Open Clip, Polymer Handguard, 1808 Waffle Splash Guard and Spout Bushing	4.3 (2.0)
177612	without Hold Open Clip, with Polymer Handguard, 1808 Waffle Splash Guard and Spout Bushing	4.2 (1.9)
177681	with Three Notch Hold Open Clip, Polymer Handguard and Spout Bushing, without Waffle Splash Guard	4.3 (2.0)
177690	with Three Notch Hold Open Clip, Polymer Handguard, POPD®S, 1808 Waffle Splash Guard and Spout Bushing	4.3 (2.0)
504010	with Three Notch Hold Open Clip, Polymer Handguard and 1808 Waffle Splash Guard, without Spout Bushing	4.2 (1.9)
504012	without Hold Open Clip and Spout Bushing, with Polymer Handguard and 1808 Waffle Splash Guard	4.2 (1.9)
651910	with Three Notch Hold Open Clip, Polymer Handguard, 1808 Waffle Splash Guard, Spout Bushing and Cold Weather Seals	4.3 (2.0)
651981	with Three Notch Hold Open Clip, Polymer Handguard, Spout Bushing and Cold Weather Seals, without Waffle Splash Guard	4.2 (1.9)
652110	with Three Notch Hold Open Clip, Polymer Handguard, 1808 Waffle Splash Guard and Cold Weather Seals, without Spout Bushing	4.3 (2.0)
1776240	with Single Notch Hold Open Clip, Polymer Handguard, 1808 Waffle Splash Guard and Spout Bushing	4.3 (2.0)
5040132	with Three Notch Hold Open Clip, and Polymer Handguard, without Waffle Splash Guard and Spout Bushing	4.2 (1.9)
6519159	without Hold Open Clip, with Polymer Handguard, 1808 Waffle Splash Guard, Spout Bushing and Cold Weather Seals	4.2 (1.9)
11043132	with Three Notch Hold Open Clip, Polymer Handguard and Short Spout Spring, without Waffle Splash Guard and Spout Bushing	4.2 (1.9)
17761001	with Three Notch Hold Open Clip, Polymer Handguard, 1808 Waffle Splash Guard, 3" Longer Spout and Spout Bushing, without StreamShaper®	4.4 (2.0)
1678110N^	with Three Notch Hold Open Clip, Polymer Handguard, 1808 Waffle Splash Guard, Cold Weather Seals and Spout Bushing	4.6 (2.0)

^ NOT LISTED

New High-Flow Diesel PHG Nozzles with BSP Inlet

MODEL NO.	DESCRIPTION	SHIPPING WEIGHT LBS (KG)
504038	with Three Notch Hold Open Clip, Polymer Handguard and 1808 Waffle Splash Guard, without Spout Bushing	0 4.2 (1.9)

^ NOT LISTED



WARNING: Cancer and Reproductive Harm - www.P65Warnings.ca.gov

VIIIS Nozzles

Pressure Activated, automatic shut-off nozzle for truck stop and other high volume full-service, self-service and unattended stations.

Dimensions

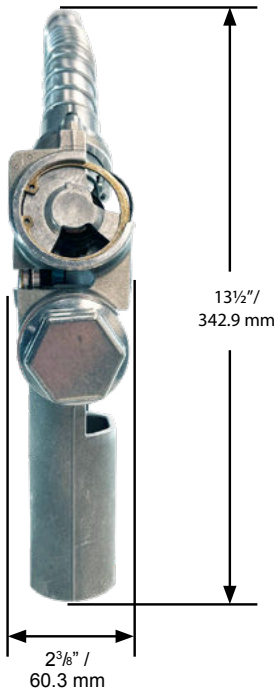
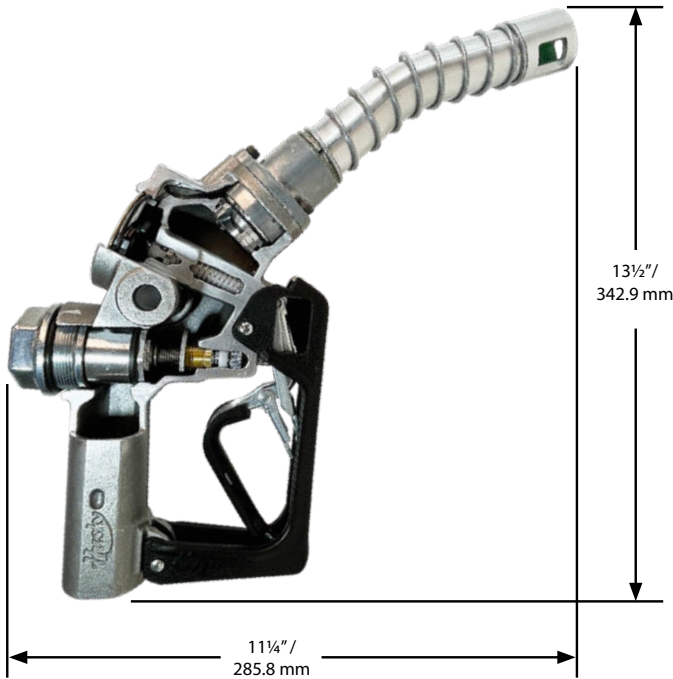

New High-Flow Diesel MHG Nozzles with NPT Inlet

MODEL NO.	DESCRIPTION	SHIPPING WEIGHT LBS (KG)
749610	with Three Notch Hold Open Clip, Metal Handguard, 1808 Waffle Splash Guard and Spout Bushing	4.5 (2.0)
749612	without Hold Open Clip, with Metal Handguard, 1808 Waffle Splash Guard and Spout Bushing	4.4 (2.0)
751010	with Three Notch Hold Open Clip, Metal Handguard and 1808 Waffle Splash Guard, without Spout Bushing	4.4 (2.0)

^ NOT LISTED

Construction

Body	One piece sand cast aluminum with high-impact polymer or metal handguard
Seals	Fluorocarbon
Packing	Double o-ring seal protected by fiber-reinforced Teflon®
Lever	One piece contoured steel with hard polymer lever cover
Inlet	1" (25.4 mm) NPT or 1" (25.4 mm) BSP

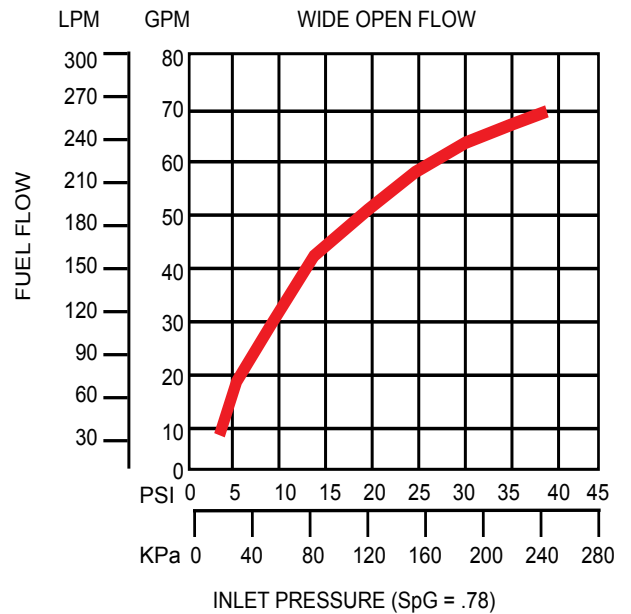

VIIIS Nozzles

Pressure Activated, automatic shut-off nozzle for truck stop and other high volume full-service, self-service and unattended stations.

Nozzle Options

Nozzle Guard Options



Full Grip Guard

POPD®S
Full Grip Guard

POPD®H
Full Grip Guard

Waffle Guard Options



1808 Waffle Guard

Handguard Options



Standard Polymer
Handguard

Standard Metal
Handguard

Gilbarco Polymer
Handguard
(with or without Magnet)

Tokheim Polymer
Handguard
(with or without Magnet)

Wayne Polymer
Handguard
(with or without Magnet)

Lever Options

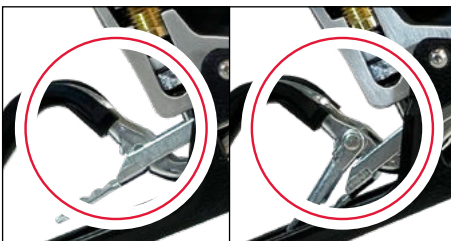

Lever without Hold
Open Clip

Lever with Hold
Open Clip

Latch Plate Options

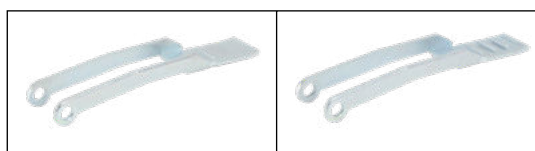

1 - Position Latch Plate

3 - Position Latch Plate

VIIIS Nozzles

Pressure Activated, automatic shut-off nozzle for truck stop and other high volume full-service, self-service and unattended stations.

System Options

Safe-T-Breaks®

MODEL NO.	DESCRIPTION
002276	1" F x 1" F NPT Reconnectable Safe-T-Break®
003076	1" F x 1" F BSPP Reconnectable Safe-T-Break®
003076A	1" F x 1" F BSPP Reconnectable Safe-T-Break® - Atex
005231	1" F x 1" F Low Pull NPT Reconnectable Safe-T-Break®
005812	1" F x 1" F NPT Non-Reconnectable Safe-T-Break®
006301	1" F x 1" F NPT Non-Reconnectable PCC Safe-T-Break®
006914	1" F x 1" F BSPP Non-Reconnectable Safe-T-Break®
008331	1" F x 1" F NPT CK Reconnectable MAGBREAK®
009911	1" F x 1" F BSPP Reconnectable G2 MAGBREAK®

Swivel/Safe-T-Break® Combos

MODEL NO.	DESCRIPTION
005969	1" M NPT Multi-Plane Swivel connected to 1" F NPT Reconnectable Safe-T-Break®
008015	1" M BSPP Multi-Plane Swivel connected to 1" F BSPP Reconnectable Safe-T-Break®
008015A	1" M BSPP Multi-Plane Swivel connected to 1" F BSPP Reconnectable Safe-T-Break® - Atex

Spouts

MODEL NO.	DESCRIPTION
002279	Complete Spout Assembly with Spout Bushing
003589	Complete Long Spout Assembly without Spout Bushing
005017	Complete Spout Assembly without Spout Bushing
007218	Complete Long Spout Assembly with Spout Bushing
011043	Complete Spout Assembly without Spout Bushing, with Small Spout Spring
011129	Complete Long Spout Assembly without Spout Bushing and UL Groove
010434	Unleaded Long Spout with StreamShaper®

Pressure/Vacuum Vents

MODEL NO.	DESCRIPTION
004620	2" Slip-On Pressure Vacuum Vent
004885	2" Thread-On Pressure Vacuum Vent - NPT
005885	2" Thread-On Pressure Vacuum Vent with Internal Screen - NPT

Accessories, Testing and Maintenance

MODEL NO.	DESCRIPTION
003593	Hold Open Clip Kit
006645	Plunger Assembly Lift Tool
007089	Nozzle Service Kit

Swivels

MODEL NO.	DESCRIPTION
000087	1" M x 1" F NPT Multi-Plane Swivel
000095	1" M x 1" F NPT 70° Multi-Plane Swivel
003306	1" M x 1" F BSPP Multi-Plane Swivel
003395	1" M x 1" F NPT Multi-Plane Restricted Swivel
004860	1" M x 1" F NPT Multi-Plane High Volume Swivel
006949	1" M x 1" F BSPP Multi-Plane High Volume Swivel

Guards

MODEL NO.	DESCRIPTION
001808	Waffle Splash Guard
004740	Full Grip Guard
005494	Lever Guard
005516	Full Grip Reguard
006628	POPD® S Clear Cover
007352	POPD® S Full Grip Guard
007999	POPD® H Clear Cover
008167	POPD® S Mate Guard
008168	POPD® H Mate Guard
008177	POPD® EZS Nozzle Guard
008178	POPD® EZH Nozzle Guard
008186	POPD® H Full Grip Guard
008193	POPD® H Full Grip Reguard
008194	POPD® S Full Grip Reguard

Guard Color Chart

COLOR	SUFFIX	COLOR	SUFFIX	COLOR <i>CUSTOM</i>	SUFFIX
Blue	-01	Gold	-08	Amoco Blue	-07 <i>CUSTOM</i>
Red	-02	Silver	-09	Apple Green	-18 <i>CUSTOM</i>
Green	-03	BP Green	-16	Purple	-19 <i>CUSTOM</i>
Black	-04	M Blue	-21	Pink	-20 <i>CUSTOM</i>
Yellow	-05	Orange	-39	BPS Green	-22 <i>CUSTOM</i>
White	-06				

Scuff Guards are to be ordered with the corresponding guard color option added to the model number. Example: If BLUE guards are desired, add guard color option -01 to the model number (159504-01). For custom colors, a minimum order of 4,000 guards will be required.

VIII Nozzles

Automatic shut-off nozzle for truck stop and other high volume full-service, self-service and unattended stations.

- VIII nozzle shuts off when the gas tank is full.
- Optional aluminum bushing retains spout spring and keeps spout from rounding-in: the two leading causes of clicking off and splash-back spillage.
- Nozzle is equipped with a unique Flo-Stop® device that shuts off the nozzle if it falls from the fill neck or raises above the horizontal.
- *StreamShaper*® reduces turbulence for straighter fuel flow and less splash back spillage.
- Strong flow (up to 75 gpm / 283.9 Lpm)
- Dual poppet design equalizes pressure on both sides of the main poppet valve in order to aid in lifting the lever, and ultimately opening the main poppet valve for full flow.
- Optional cold weather seals are rated to -40 °F/C.
- Optional Gilbarco, Tokheim, and Wayne handguards can be fitted with a magnet to trigger the dispenser's proximity switch, or can be provided without the magnet for dispensers equipped with a standard "flapper" switch.
- Comes standard with smooth full grip guard and 1808 waffle splash guard.



MODEL NO.
173312

New High-Flow Diesel PHG Nozzles with NPT Inlet

MODEL NO.	DESCRIPTION	SHIPPING WEIGHT LBS (KG)
173312	without Hold Open Clip, with Polymer Handguard, 1808 Waffle Splash Guard and Spout Bushing	4.3 (2.0)
503012	without Hold Open Clip and Spout Bushing, with Polymer Handguard and 1808 Waffle Splash Guard	4.2 (1.9)
651512	without Hold Open Clip, with Polymer Handguard, 1808 Waffle Splash Guard, Spout Bushing and Cold Weather Seals	4.3 (2.0)
173310N [^]	with Three Notch Hold Open Clip, Polymer Handguard, 1808 Waffle Splash Guard and Spout Bushing	4.3 (2.0)
173310NR [^]	with Three Notch Hold Open Clip, Polymer Handguard, 1808 Waffle Splash Guard and Spout Bushing - in Retail Packaging	4.2 (1.9)
173381N [^]	with Three Notch Hold Open Clip, Polymer Handguard and Spout Bushing, without Waffle Splash Guard	4.2 (1.9)
503010N [^]	with Three Notch Hold Open Clip, Polymer Handguard and 1808 Waffle Splash Guard, without Spout Bushing	4.2 (1.9)
503081N [^]	with Three Notch Hold Open Clip and Polymer Handguard, without Waffle Splash Guard and Spout Bushing	4.1 (1.9)
651510N [^]	with Three Notch Hold Open Clip, Polymer Handguard, 1808 Waffle Splash Guard and Cold Weather Seals, without Spout Bushing	4.3 (2.0)
17331001N [^]	with Three Notch Hold Open Clip, Polymer Handguard, 1808 Waffle Splash Guard and 3" Longer Spout, without StreamShaper®	4.4 (2.0)
1679710N [^]	with Three Notch Hold Open Clip, Polymer Handguard, 1808 Waffle Splash Guard and Cold Weather Seals and Spout Bushing	4.4 (2.0)

[^] NOT LISTED

New High-Flow Diesel PHG Nozzles with BSP Inlet

MODEL NO.	DESCRIPTION	SHIPPING WEIGHT LBS (KG)
173338N [^]	with Three Notch Hold Open Clip, Polymer Handguard, 1808 Waffle Splash Guard and Spout Bushing	4.3 (2.0)
503038N [^]	with Three Notch Hold Open Clip, Polymer Handguard and 1808 Waffle Splash Guard, without Spout Bushing	4.2 (1.9)
1058538N [^]	with Three Notch Hold Open Clip, Polymer Handguard and 1808 Waffle Splash Guard, without Spout Bushing and UL Spout Groove	4.2 (1.9)
13705213N [^]	with Three Notch Hold Open Clip and Tokheim Magnetic Handguard, without Waffle Splash Guard and Spout Bushing	4.1 (1.9)
105853801N [^]	with Three Notch Hold Open Clip, Polymer Handguard, 1808 Waffle Splash Guard and 3" Longer Spout, without StreamShaper®, Spout Bushing and UL Spout Groove	4.4 (2.0)

[^] NOT LISTED



WARNING: Cancer and Reproductive Harm - www.P65Warnings.ca.gov

VIII Nozzles

Automatic shut-off nozzle for truck stop and other high volume full-service, self-service and unattended stations.

Dimensions

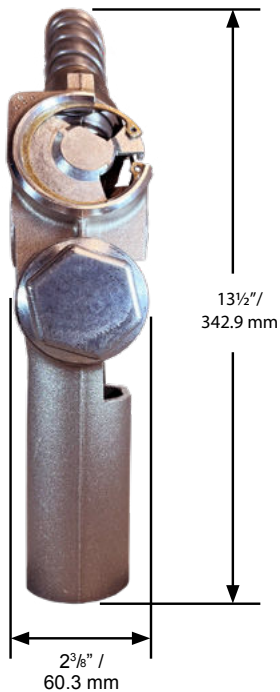
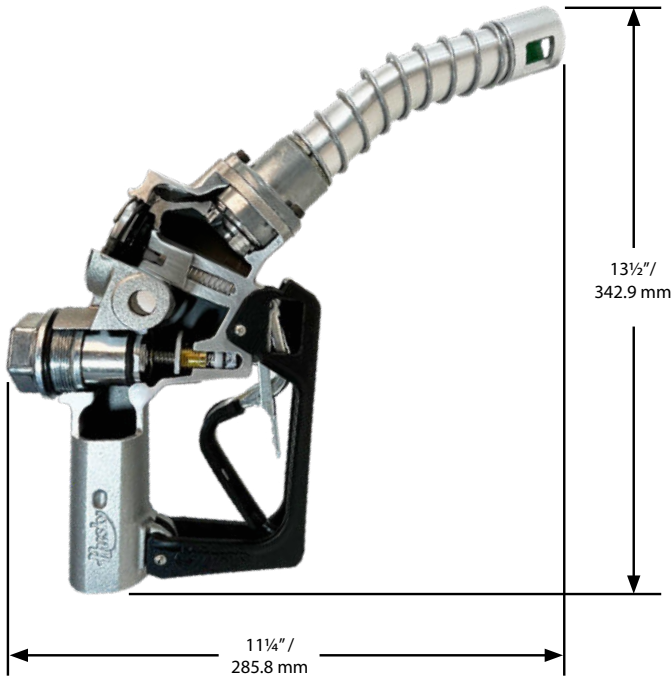

New High-Flow Diesel MHG Nozzles with NPT Inlet

MODEL NO.	DESCRIPTION	SHIPPING WEIGHT LBS (KG)
749312	without Hold Open Clip, with Polymer Handguard, 1808 Waffle Splash Guard and Spout Bushing	4.5 (2.0)
750612	without Hold Open Clip and Spout Bushing, with Metal Handguard and 1808 Waffle Splash Guard	4.4 (2.0)
749310N [^]	with Three Notch Hold Open Clip, Metal Handguard, 1808 Waffle Splash Guard and Spout Bushing	4.5 (2.0)
750610N [^]	with Three Notch Hold Open Clip, Metal Handguard and 1808 Waffle Splash Guard, without Spout Bushing	4.4 (2.0)
751510N [^]	with Three Notch Hold Open Clip, Metal Handguard, 1808 Waffle Splash Guard, Spout Bushing and Cold Weather Seals	4.5 (2.0)
7506230N [^]	with Three Notch Hold Open Clip, Metal Handguard, 1808 Waffle Splash Guard and Short Spout Spring, without Spout Bushing	4.4 (2.0)
750623001N [^]	with Three Notch Hold Open Clip, Metal Handguard, 1808 Waffle Splash Guard, 3" Longer Spout and Short Spout Spring, without StreamShaper [®] and Spout Bushing	4.5 (2.0)

[^] NOT LISTED

New High-Flow Diesel MHG Nozzles with BSP Inlet

MODEL NO.	DESCRIPTION	SHIPPING WEIGHT LBS (KG)
749338N [^]	with Three Notch Hold Open Clip, Metal Handguard, 1808 Waffle Splash Guard and Spout Bushing	4.5 (2.0)

[^] NOT LISTED

Construction

Body	One piece sand cast aluminum with high-impact polymer or metal handguard
Seals	Fluorocarbon
Packing	Double o-ring seal protected by fiber-reinforced Teflon [®]
Lever	One piece contoured steel with hard polymer lever cover
Inlet	1" (25.4 mm) NPT or 1" (25.4 mm) BSP

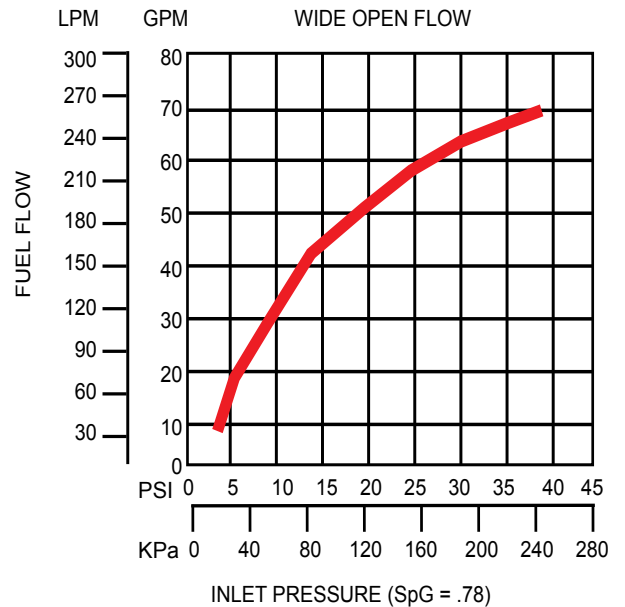

VIII Nozzles



TRUCK AND HIGH VOLUME

Automatic shut-off nozzle for truck stop and other high volume full-service, self-service and unattended stations.

Nozzle Options

Nozzle Guard Options



Full Grip Guard

POPD®S
Full Grip Guard

POPD®H
Full Grip Guard

Waffle Guard Options



1808 Waffle Guard

Handguard Options



Standard Polymer
Handguard

Standard Metal
Handguard

Gilbarco Polymer
Handguard
(with or without Magnet)

Tokheim Polymer
Handguard
(with or without Magnet)

Wayne Polymer
Handguard
(with or without Magnet)

Lever Options

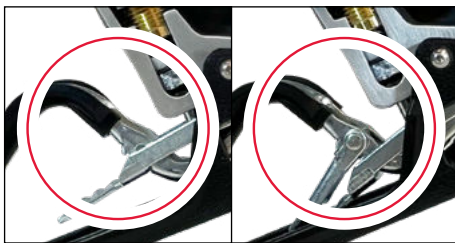

Lever without Hold
Open Clip

Lever with Hold
Open Clip

Latch Plate Options

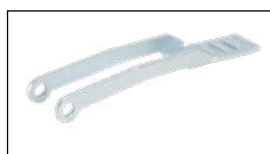

3 - Position Latch Plate

VIII Nozzles

Automatic shut-off nozzle for truck stop and other high volume full-service, self-service and unattended stations.

System Options

Safe-T-Breaks®

MODEL NO.	DESCRIPTION
002276	1" F x 1" F NPT Reconnectable Safe-T-Break®
003076	1" F x 1" F BSPP Reconnectable Safe-T-Break®
003076A	1" F x 1" F BSPP Reconnectable Safe-T-Break® - Atex
005231	1" F x 1" F Low Pull NPT Reconnectable Safe-T-Break®
005812	1" F x 1" F NPT Non-Reconnectable Safe-T-Break®
006301	1" F x 1" F NPT Non-Reconnectable PCC Safe-T-Break®
006914	1" F x 1" F BSPP Non-Reconnectable Safe-T-Break®
008331	1" F x 1" F NPT CK Reconnectable MAGBREAK®
009911	1" F x 1" F BSPP Reconnectable G2 MAGBREAK®

Swivel/Safe-T-Break® Combos

MODEL NO.	DESCRIPTION
005969	1" M NPT Multi-Plane Swivel connected to 1" F NPT Reconnectable Safe-T-Break®
008015	1" M BSPP Multi-Plane Swivel connected to 1" F BSPP Reconnectable Safe-T-Break®
008015A	1" M BSPP Multi-Plane Swivel connected to 1" F BSPP Reconnectable Safe-T-Break® - Atex

Spouts

MODEL NO.	DESCRIPTION
002279	Complete Spout Assembly with Spout Bushing
003589	Complete Long Spout Assembly without Spout Bushing
005017	Complete Spout Assembly without Spout Bushing
007218	Complete Long Spout Assembly with Spout Bushing
011043	Complete Spout Assembly without Spout Bushing, with Small Spout Spring
011129	Complete Long Spout Assembly without Spout Bushing and UL Groove
010434	Unleaded Long Spout with StreamShaper®

Pressure/Vacuum Vents

MODEL NO.	DESCRIPTION
004620	2" Slip-On Pressure Vacuum Vent
004885	2" Thread-On Pressure Vacuum Vent - NPT
005885	2" Thread-On Pressure Vacuum Vent with Internal Screen - NPT

Accessories, Testing and Maintenance

MODEL NO.	DESCRIPTION
003593	Hold Open Clip Kit
006645	Plunger Assembly Lift Tool
007089	Nozzle Service Kit

Swivels

MODEL NO.	DESCRIPTION
000087	1" M x 1" F NPT Multi-Plane Swivel
000095	1" M x 1" F NPT 70° Multi-Plane Swivel
003306	1" M x 1" F BSPP Multi-Plane Swivel
003395	1" M x 1" F NPT Multi-Plane Restricted Swivel
004860	1" M x 1" F NPT Multi-Plane High Volume Swivel
006949	1" M x 1" F BSPP Multi-Plane High Volume Swivel

Guards

MODEL NO.	DESCRIPTION
001808	Waffle Splash Guard
004740	Full Grip Guard
005494	Lever Guard
005516	Full Grip Reguard
006628	POPD® S Clear Cover
007352	POPD® S Full Grip Guard
007999	POPD® H Clear Cover
008167	POPD® S Mate Guard
008168	POPD® H Mate Guard
008177	POPD® EZS Nozzle Guard
008178	POPD® EZH Nozzle Guard
008186	POPD® H Full Grip Guard
008193	POPD® H Full Grip Reguard
008194	POPD® S Full Grip Reguard

Guard Color Chart

COLOR	SUFFIX	COLOR	SUFFIX	COLOR <i>CUSTOM</i>	SUFFIX
Blue	-01	Gold	-08	Amoco Blue	-07 <i>CUSTOM</i>
Red	-02	Silver	-09	Apple Green	-18 <i>CUSTOM</i>
Green	-03	BP Green	-16	Purple	-19 <i>CUSTOM</i>
Black	-04	M Blue	-21	Pink	-20 <i>CUSTOM</i>
Yellow	-05	Orange	-39	BPS Green	-22 <i>CUSTOM</i>
White	-06				

Scuff Guards are to be ordered with the corresponding guard color option added to the model number. Example: If BLUE guards are desired, add guard color option -01 to the model number (159504-01). For custom colors, a minimum order of 4,000 guards will be required.

1HS Nozzles

Automatic shut-off nozzle with polymer handguard for dispensing up to 25 gpm / 94.6 Lpm.

- 1HS nozzle shuts off when the gas tank is full.
- Nozzle is equipped with a unique Flo-Stop® device that shuts off the nozzle if it falls from the fill neck or raises above the horizontal.
- Optional cold weather seals are rated to -40 °F/C.
- Optional Gilbarco, Tokheim, and Wayne handguards can be fitted with a magnet to trigger the dispenser's proximity switch, or can be provided without the magnet for dispensers equipped with a standard "flapper" switch.
- Comes standard with smooth full grip guard.
- ADA-compliant EZ Lever reduces the force required to open the main poppet valve by 50%, resulting in a lever operating force ≤5 lbs.



MODEL NO.
026812

New Heavy Duty Diesel PHG Nozzles with NPT Inlet

MODEL NO.	DESCRIPTION	SHIPPING WEIGHT LBS (KG)
026812	without Hold Open Clip, with Polymer Handguard	3.4 (1.5)
026810N^	with Two Notch Hold Open Clip and Polymer Handguard	3.4 (1.5)
026865N^	with Two Notch Hold Open Clip, Polymer Handguard and 1808 Waffle Splash Guard	3.5 (1.6)
E1522610N^	with Two Notch Hold Open Clip, Mate Guard and Wayne Magnetic Handguard	3.5 (1.6)

^ NOT LISTED

New Heavy Duty Diesel PHG Nozzles with BSP Inlet

MODEL NO.	DESCRIPTION	SHIPPING WEIGHT LBS (KG)
-026838A	with Two Notch Hold Open Clip and Polymer Handguard	3.4 (1.5)
026838N^	with Two Notch Hold Open Clip and Polymer Handguard	3.4 (1.5)
-E1522638A	with Two Notch Hold Open Clip, Tilt Poppet, Wayne Magnetic Handguard, Mate Guard and Polymer Handle	3.5 (1.6)

^ NOT LISTED



II 1 G
EN 13012
TYPE 2



WARNING: Cancer and Reproductive Harm - www.P65Warnings.ca.gov

1HS Nozzles

Automatic shut-off nozzle with polymer handguard for dispensing up to 25 gpm / 94.6 Lpm.

Dimensions

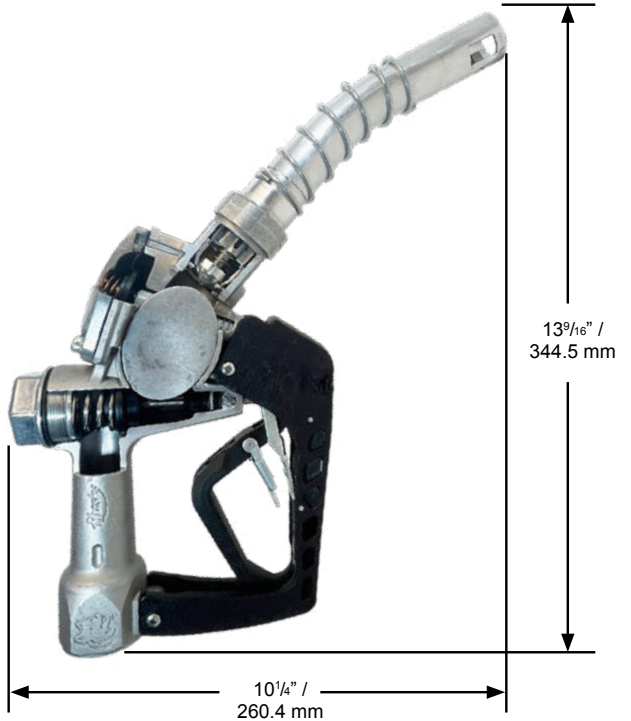

New Heavy Duty Diesel MHG Nozzles with NPT Inlet

MODEL NO.	DESCRIPTION	SHIPPING WEIGHT LBS (KG)
696310N [^]	with Two Notch Hold Open Clip and Metal Handguard	3.6 (1.6)
696365N [^]	with Two Notch Hold Open Clip, Metal Handguard and 1808 Waffle Splash Guard	3.7 (1.7)

[^] NOT LISTED

New Heavy Duty Diesel MHG Nozzles with BSP Inlet

MODEL NO.	DESCRIPTION	SHIPPING WEIGHT LBS (KG)
696338N [^]	with Two Notch Hold Open Clip and Metal Handguard	3.6 (1.6)

[^] NOT LISTED

Construction

Body	One piece die cast aluminum with high-impact polymer or metal handguard
Seals	Fluorocarbon
Packing	Double o-ring seal protected by fiber-reinforced Teflon [®]
Lever	Two-piece polymer EZ Lever
Inlet	1" (25.4 mm) NPT or 1" (25.4 mm) BSP

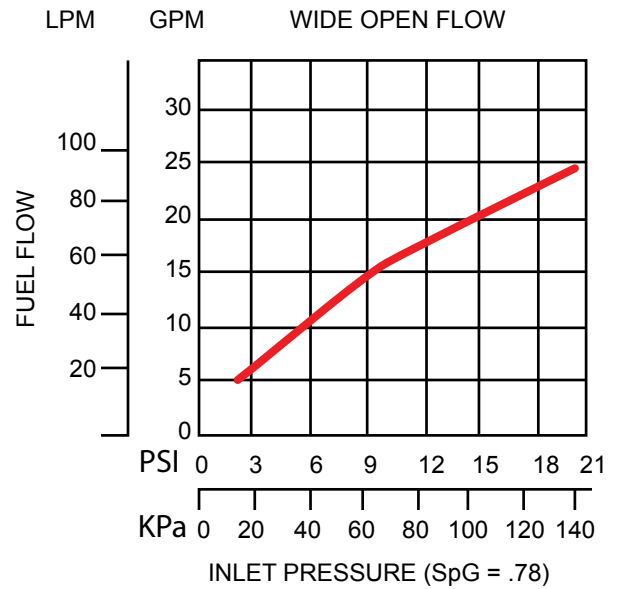

1HS Nozzles

TRUCK AND HIGH VOLUME

Automatic shut-off nozzle with polymer handguard for dispensing up to 25 gpm / 94.6 Lpm.

Nozzle Options

Nozzle Guard Options



Full Grip Guard

POPD®S Full Grip Guard

POPD®H Full Grip Guard

Mate Guard

POPD®S Mate Guard

POPD®H Mate Guard

Waffle Guard Options



1808 Waffle Guard

Handguard Options



Standard Polymer Handguard

Standard Metal Handguard

Gilbarco Polymer Handguard
(with or without Magnet)

Tokheim Polymer Handguard
(with or without Magnet)

Wayne Polymer Handguard
(with or without Magnet)

Lever Options



Lever without Hold Open Clip



Lever with Hold Open Clip

Latch Plate Options

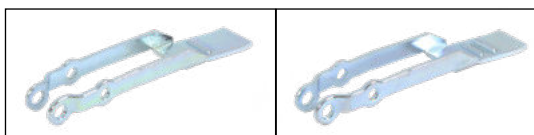

1 - Position Latch Plate

2 - Position Latch Plate

1HS Nozzles

Automatic shut-off nozzle with polymer handguard for dispensing up to 25 gpm / 94.6 Lpm.

System Options

Safe-T-Breaks®

MODEL NO.	DESCRIPTION
002276	1" F x 1" F NPT Reconnectable Safe-T-Break®
003076	1" F x 1" F BSPP Reconnectable Safe-T-Break®
003076A	1" F x 1" F BSPP Reconnectable Safe-T-Break® - Atex
005231	1" F x 1" F Low Pull NPT Reconnectable Safe-T-Break®
005812	1" F x 1" F NPT Non-Reconnectable Safe-T-Break®
006301	1" F x 1" F NPT Non-Reconnectable PCC Safe-T-Break®
006914	1" F x 1" F BSPP Non-Reconnectable Safe-T-Break®
008331	1" F x 1" F NPT CK Reconnectable MAGBREAK®
009911	1" F x 1" F BSPP Reconnectable G2 MAGBREAK®

Swivel/Safe-T-Break® Combos

MODEL NO.	DESCRIPTION
005969	1" M NPT Multi-Plane Swivel connected to 1" F NPT Reconnectable Safe-T-Break®
008015	1" M BSPP Multi-Plane Swivel connected to 1" F BSPP Reconnectable Safe-T-Break®
008015A	1" M BSPP Multi-Plane Swivel connected to 1" F BSPP Reconnectable Safe-T-Break® - Atex Spouts

Spouts

MODEL NO.	DESCRIPTION
005215	Heavy Duty Diesel Spout

Pressure/Vacuum Vents

MODEL NO.	DESCRIPTION
004620	2" Slip-On Pressure Vacuum Vent
004885	2" Thread-On Pressure Vacuum Vent - NPT
005885	2" Thread-On Pressure Vacuum Vent with Internal Screen - NPT

Accessories, Testing and Maintenance

MODEL NO.	DESCRIPTION
000385	1" M x 3/4" F Reducer Bushing
000397	Unleaded Spout Gauge
003593	Hold Open Clip Kit
007089	Nozzle Service Kit

Swivels

MODEL NO.	DESCRIPTION
000087	1" M x 1" F NPT Multi-Plane Swivel
000095	1" M x 1" F NPT 70° Multi-Plane Swivel
000352	1" M x 3/4" F NPT Multi-Plane Swivel
000356	1" M x 3/4" F NPT Multi-Plane Swivel Anodized Black
003306	1" M x 1" F BSPP Multi-Plane Swivel
003306A	1" M x 1" F BSPP Multi-Plane Swivel - Atex
003395	1" M x 1" F NPT Multi-Plane Restricted Swivel
004860	1" M x 1" F NPT Multi-Plane High Volume Swivel
006949	1" M x 1" F BSPP Multi-Plane High Volume Swivel

Guards

MODEL NO.	DESCRIPTION
000099	Protection Package
000226	Mate Nozzle Guard
000554	Full Grip Guard
001804	Full Grip Reguard
001808	Waffle Splash Guard
001811	Reguard Protection Package
005494	Lever Guard
006628	POPD® S Clear Cover
006655	POPD® S Full Grip Guard
007210	POPD® S Full Grip Reguard
007295	Mate Handle Guard
007999	POPD® H Clear Cover
008169	POPD® S Mate Nozzle Guard
008170	POPD® H Mate Nozzle Guard
008179	POPD® EZS Nozzle Guard
008180	POPD® EZH Nozzle Guard
008183	POPD® H Full Grip Guard
008190	POPD® H Full Grip Reguard

Guard Color Chart

COLOR	SUFFIX	COLOR	SUFFIX	COLOR <i>CUSTOM</i>	SUFFIX
Blue	-01	Gold	-08	Amoco Blue	-07 <i>CUSTOM</i>
Red	-02	Silver	-09	Apple Green	-18 <i>CUSTOM</i>
Green	-03	BP Green	-16	Purple	-19 <i>CUSTOM</i>
Black	-04	M Blue	-21	Pink	-20 <i>CUSTOM</i>
Yellow	-05	Orange	-39	BPS Green	-22 <i>CUSTOM</i>
White	-06				

Scuff Guards are to be ordered with the corresponding guard color option added to the model number. Example: If BLUE guards are desired, add guard color option -01 to the model number (159504-01). For custom colors, a minimum order of 4,000 guards will be required.

1HSS Nozzles

Automatic shut-off nozzle with polymer handguard for dispensing up to 25 gpm / 94.6 Lpm.

- 1HSS nozzle shuts off when:
 - the pump shuts off.
 - the gas tank is full.
 - the lever is opened before the pump is turned on.
 - the leak detector has not completed the test cycle.
- Comes standard with smooth full grip guard.
- ADA-compliant EZ Lever reduces the force required to open the main poppet valve by 50%, resulting in a lever operating force ≤5 lbs.
- Nozzle is equipped with a unique Flo-Stop® device that shuts off the nozzle if it falls from the fill neck or raises above the horizontal.
- Optional cold weather seals are rated to -40 °F/C.
- Optional Gilbarco, Tokheim, and Wayne handguards can be fitted with a magnet to trigger the dispenser's proximity switch, or can be provided without the magnet for dispensers equipped with a standard "flapper" switch.



MODEL NO.
1217110

New Heavy Duty Diesel PHG Nozzles with NPT Inlet

MODEL NO.	DESCRIPTION	SHIPPING WEIGHT LBS (KG)
1217110	with Two Notch Hold Open Clip and Polymer Handguard	3.4 (1.5)
1217110N^	with Two Notch Hold Open Clip and Polymer Handguard	3.4 (1.5)
12171266	with Two Notch Hold Open Clip, Waffle Guard, Inlet Screen (Strainer) and Polymer Handguard	3.4 (1.5)

New Heavy Duty Diesel PHG Nozzles with BSP Inlet

MODEL NO.	DESCRIPTION	SHIPPING WEIGHT LBS (KG)
1217138N^	with Two Notch Hold Open Clip and Polymer Handguard	3.4 (1.5)
1217138	with Two Notch Hold Open Clip and Polymer Handguard	3.4 (1.5)

New Heavy Duty Diesel PHG Nozzles with BSP Inlet

MODEL NO.	DESCRIPTION	SHIPPING WEIGHT LBS (KG)
1217410	with Two Notch Hold Open Clip and Metal Handguard	3.5 (1.6)

^ NOT LISTED



II 1 G
EN 13012
TYPE 2



WARNING: Cancer and Reproductive Harm - www.P65Warnings.ca.gov

1HSS Nozzles

Automatic shut-off nozzle with polymer handguard for dispensing up to 25 gpm / 94.6 Lpm.

Dimensions

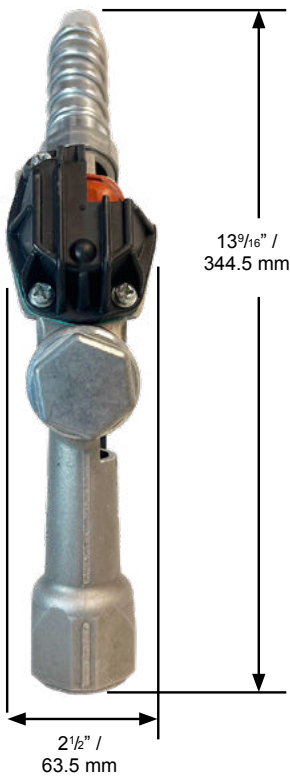
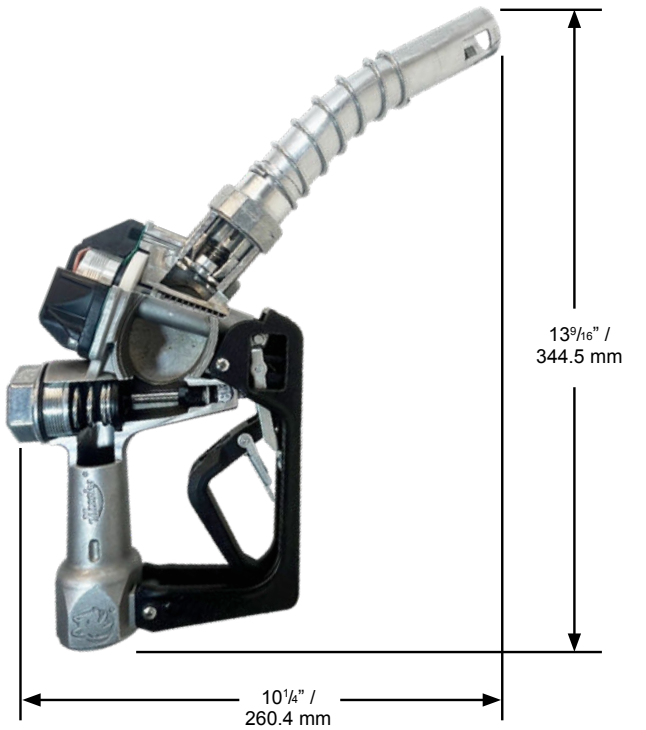

Construction

Body	One piece die cast aluminum with high-impact polymer or metal handguard
Seals	Fluorocarbon
Packing	Double o-ring seal protected by fiber-reinforced Teflon®
Lever	Two-piece polymer EZ Lever
Inlet	1" (25.4 mm) NPT or 1" (25.4 mm) BSP

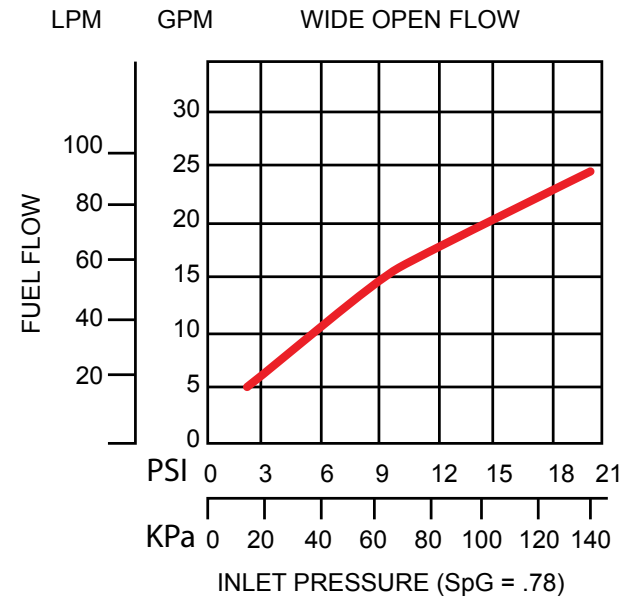

1HSS Nozzles

TRUCK AND HIGH VOLUME

Automatic shut-off nozzle with polymer handguard for dispensing up to 25 gpm / 94.6 Lpm.

Nozzle Options

Nozzle Guard Options



Full Grip Guard

POPD®S Full Grip Guard

POPD®H Full Grip Guard

Mate Guard

POPD®S Mate Guard

POPD®H Mate Guard

Waffle Guard Options



1808 Waffle Guard

Handguard Options



Standard Polymer Handguard

Standard Metal Handguard

Gilbarco Polymer Handguard
(with or without Magnet)

Tokheim Polymer Handguard
(with or without Magnet)

Wayne Polymer Handguard
(with or without Magnet)

Lever Options



Lever without Hold Open Clip



Lever with Hold Open Clip

Latch Plate Options

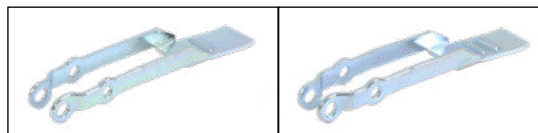

1 - Position Latch Plate

2 - Position Latch Plate

1HSS Nozzles

Automatic shut-off nozzle with polymer handguard for dispensing up to 25 gpm / 94.6 Lpm.

System Options

Safe-T-Breaks®

MODEL NO.	DESCRIPTION
002276	1" F x 1" F NPT Reconnectable Safe-T-Break®
003076	1" F x 1" F BSPP Reconnectable Safe-T-Break®
003076A	1" F x 1" F BSPP Reconnectable Safe-T-Break® - Atex
005231	1" F x 1" F Low Pull NPT Reconnectable Safe-T-Break®
005812	1" F x 1" F NPT Non-Reconnectable Safe-T-Break®
006301	1" F x 1" F NPT Non-Reconnectable PCC Safe-T-Break®
006914	1" F x 1" F BSPP Non-Reconnectable Safe-T-Break®
008331	1" F x 1" F NPT CK Reconnectable MAGBREAK®
009911	1" F x 1" F BSPP Reconnectable G2 MAGBREAK®

Swivel/Safe-T-Break® Combos

MODEL NO.	DESCRIPTION
005969	1" M NPT Multi-Plane Swivel connected to 1" F NPT Reconnectable Safe-T-Break®
008015	1" M BSPP Multi-Plane Swivel connected to 1" F BSPP Reconnectable Safe-T-Break®
008015A	1" M BSPP Multi-Plane Swivel connected to 1" F BSPP Reconnectable Safe-T-Break® - Atex Spouts

Spouts

MODEL NO.	DESCRIPTION
005215	Heavy Duty Diesel Spout

Pressure/Vacuum Vents

MODEL NO.	DESCRIPTION
004620	2" Slip-On Pressure Vacuum Vent
004885	2" Thread-On Pressure Vacuum Vent - NPT
005885	2" Thread-On Pressure Vacuum Vent with Internal Screen - NPT

Accessories, Testing and Maintenance

MODEL NO.	DESCRIPTION
000385	1" M x 3/4" F Reducer Bushing
003593	Hold Open Clip Kit
007089	Nozzle Service Kit

Swivels

MODEL NO.	DESCRIPTION
000087	1" M x 1" F NPT Multi-Plane Swivel
000095	1" M x 1" F NPT 70° Multi-Plane Swivel
000352	1" M x 3/4" F NPT Multi-Plane Swivel
000356	1" M x 3/4" F NPT Multi-Plane Swivel Anodized Black
003306	1" M x 1" F BSPP Multi-Plane Swivel
003306A	1" M x 1" F BSPP Multi-Plane Swivel - Atex
003395	1" M x 1" F NPT Multi-Plane Restricted Swivel
004860	1" M x 1" F NPT Multi-Plane High Volume Swivel
006949	1" M x 1" F BSPP Multi-Plane High Volume Swivel

Guards

MODEL NO.	DESCRIPTION
001807	Waffle Splash Guard with Smaller Hole
001808	Waffle Splash Guard
005494	Lever Guard
007295	Mate Handle Guard
012164	Full Grip Guard

Guard Color Chart

COLOR	SUFFIX	COLOR	SUFFIX	COLOR <i>CUSTOM</i>	SUFFIX
Blue	-01	Gold	-08	Amoco Blue	-07 <i>CUSTOM</i>
Red	-02	Silver	-09	Apple Green	-18 <i>CUSTOM</i>
Green	-03	BP Green	-16	Purple	-19 <i>CUSTOM</i>
Black	-04	M Blue	-21	Pink	-20 <i>CUSTOM</i>
Yellow	-05	Orange	-39	BPS Green	-22 <i>CUSTOM</i>
White	-06				

Scuff Guards are to be ordered with the corresponding guard color option added to the model number. Example: If BLUE guards are desired, add guard color option -01 to the model number (159504-01). For custom colors, a minimum order of 4,000 guards will be required.

1690/1691 Nozzles

Automatic shut-off bulk fueling nozzle.

- Designed with extra large hand opening to accommodate gloves or mittens.
- Equipped with dual poppets for easy opening.
- Design includes a self-adjusting stem packing.
- Check valve is in the nozzle body, not the spout, which makes for an inexpensive and fast spout replacement.
- 1690 nozzle is equipped with two-position hold open latch.
- 1691 nozzle is not equipped with a hold open latch.
- Right angle design allows nozzle to “fit” close to walls and corners.
- Cast-in protective standoffs provide durability with rough usage.
- Nozzle is 30% lighter than similar nozzles in the market.

New High Volume Nozzles with NPT Inlet

MODEL NO.	DESCRIPTION	SHIPPING WEIGHT LBS (KG)
169112	without Hold Open Pins, with Shear Groove in Spout	4.6 (2.0)
169010N [^]	with Two-Position Hold Open Pins	4.6 (2.0)
652310N [^]	with Two-Position Hold Open Pins and Cold Weather Seals	4.6 (2.0)

[^] NOT LISTED

New High Volume Nozzles with BSP Inlet

MODEL NO.	DESCRIPTION	SHIPPING WEIGHT LBS (KG)
169038N [^]	with Two-Position Hold Open Pins	4.6 (2.0)

[^] NOT LISTED



MODEL NO.
169010N



 WARNING: Cancer and Reproductive Harm - www.P65Warnings.ca.gov

1690/1691 Nozzles

Automatic shut-off bulk fueling nozzle.

Dimensions



Construction

Body	One piece sand cast aluminum
Seals	Fluorocarbon
Packing	Double o-ring seal protected by fiber-reinforced Teflon®
Lever	One piece contoured steel
Inlet	1-1/2" (38.1 mm) NPT or 1-1/2" (38.1 mm) BSP

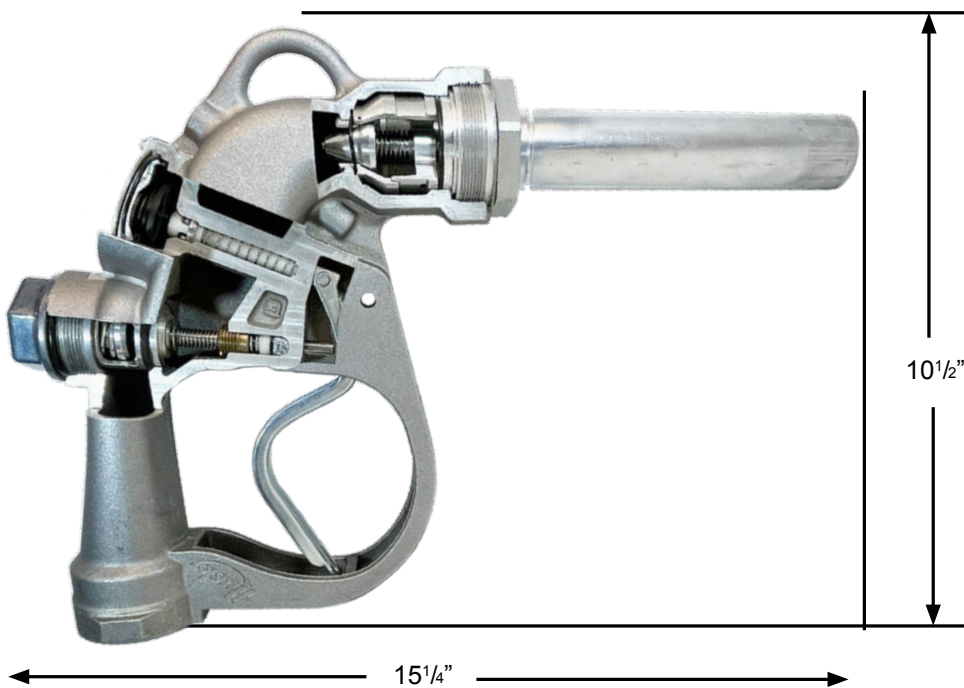
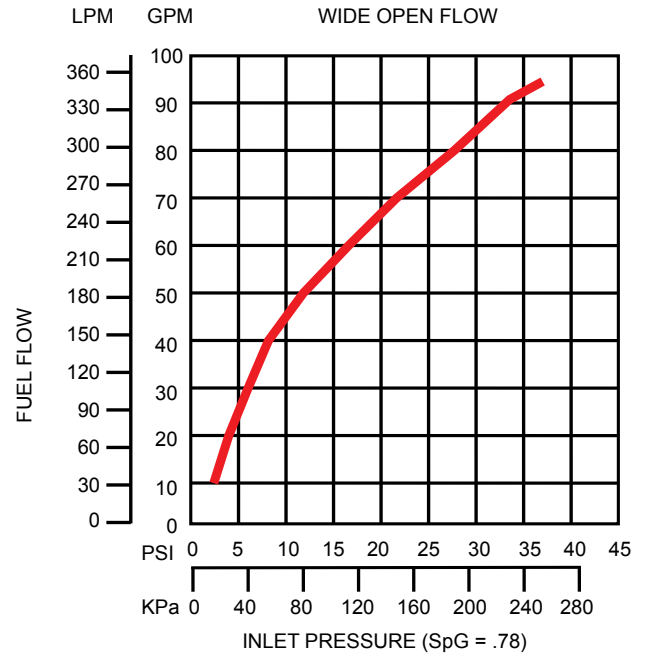

1690/1691 **Nozzles**

Automatic shut-off bulk fueling nozzle.

Nozzle Options

Hold Open Latch Pin Options

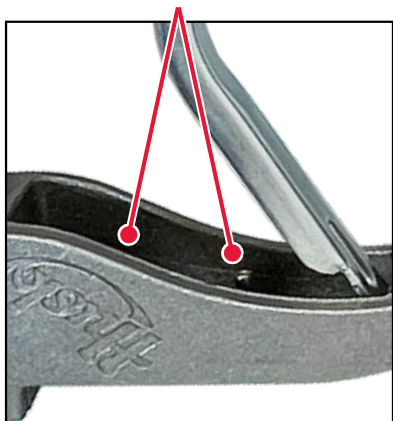

With Hold Open Latch Pins



Without Hold Open Latch Pins

UL Shear Groove Option

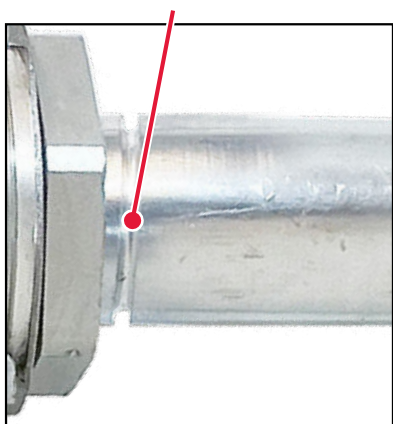

With UL Spout Shear Groove

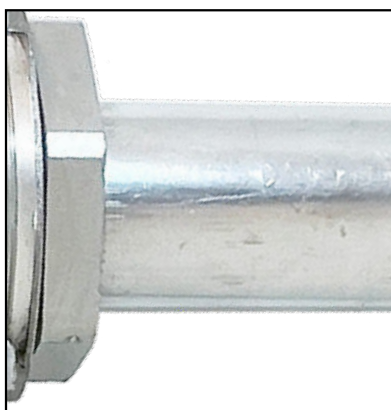

Without UL Spout Shear Groove

1690/1691 Nozzles

Automatic shut-off bulk fueling nozzle.

System Options

Spouts

MODEL NO.	DESCRIPTION
004889	Spout Assembly without Shear Groove
005042	Spout Assembly with shear groove (1691 CUL model)

Pressure/Vacuum Vents

MODEL NO.	DESCRIPTION
004620	2" Slip-On Pressure Vacuum Vent
004885	2" Thread-On Pressure Vacuum Vent - NPT
005885	2" Thread-On Pressure Vacuum Vent with Internal Screen - NPT

Accessories, Testing and Maintenance

MODEL NO.	DESCRIPTION
007089	Nozzle Service Kit

Swivels

MODEL NO.	DESCRIPTION
005240	1-1/4" F x 1-1/2" M NPT Single Plane Swivel
005266	1-1/2" F x 1-1/2" M NPT Single Plane Swivel
005754	1-1/4" F x 1-1/2" M BSPP Single Plane Swivel
005755	1-1/2" F x 1-1/2" M BSPP Single Plane Swivel



Farm & Commercial Nozzles

XFS® Nozzles

Automatic shut-off nozzle for farm, 12V skid tanks and consumer pump applications.

- XFS® nozzle shuts off when the gas tank is full.
- Stainless steel reinforced unleaded spout bushing keeps spout tip round, and acts as a captive fastener to prevent tip-end sensor damage.
- Nozzle is equipped with a unique Flo-Stop® device that shuts off the nozzle if it falls from the fill neck or raises above the horizontal.
- Unleaded *StreamShaper*® reduces turbulence for straighter fuel flow and less splash back spillage.
- Strong flow (up to 18 gpm / 68.1 Lpm)
- Dispenses 10 gpm / 37.8 Lpm at only 5.6 psi / 0.38 bar (unleaded nozzle).
- Has built-in hook and fits “holster lock” of skid tank pumps.
- Optional cold weather seals are rated to -40° F/C.
- Comes standard with smooth full grip guard.
- Not for use with gravity tanks.
- Not legal for retail dispensing applications.



MODEL NO.
337008

New Unleaded Nozzles with NPT Inlet

MODEL NO.	DESCRIPTION	SHIPPING WEIGHT LBS (KG)
337008	without Hold Open Clip	3.0 (1.4)
337004N^	with Single Notch Hold Open Clip	3.0 (1.4)
337004NR^	with Single Notch Hold Open Clip - in Retail Packaging	3.0 (1.4)
503404N^	with Single Notch Hold Open Clip, without Hanging Hook	2.9 (1.3)

^ NOT LISTED

New Unleaded Nozzles with BSP Inlet

MODEL NO.	DESCRIPTION	SHIPPING WEIGHT LBS (KG)
337016N^	with Single Notch Hold Open Clip	2.9 (1.3)

^ NOT LISTED

New Light Duty Diesel Nozzles with NPT Inlet

MODEL NO.	DESCRIPTION	SHIPPING WEIGHT LBS (KG)
337007	without Hold Open Clip	3.0 (1.4)
503407	without Hold Open Clip and Hanging Hook	2.9 (1.3)
337003N^	with Single Notch Hold Open Clip	3.0 (1.4)
337003NR^	with Single Notch Hold Open Clip - in Retail Packaging	3.0 (1.4)
503403N^	with Single Notch Hold Open Clip, without Hanging Hook	2.9 (1.3)
1700203N^	with Single Notch Hold Open Clip, without Hanging Hook	2.9 (1.3)

^ NOT LISTED

New Light Duty Diesel Nozzles with BSP Inlet

MODEL NO.	DESCRIPTION	SHIPPING WEIGHT LBS (KG)
337015N^	with Single Notch Hold Open Clip	3.0 (1.4)

^ NOT LISTED



⚠ WARNING: Cancer and Reproductive Harm - www.P65Warnings.ca.gov

XFS[®] Nozzles

Automatic shut-off nozzle for farm, 12V skid tanks and consumer pump applications.

Dimensions

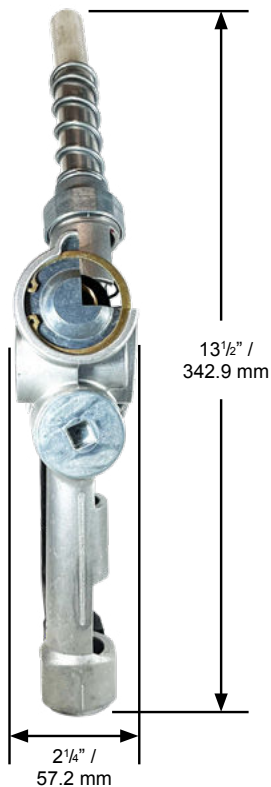
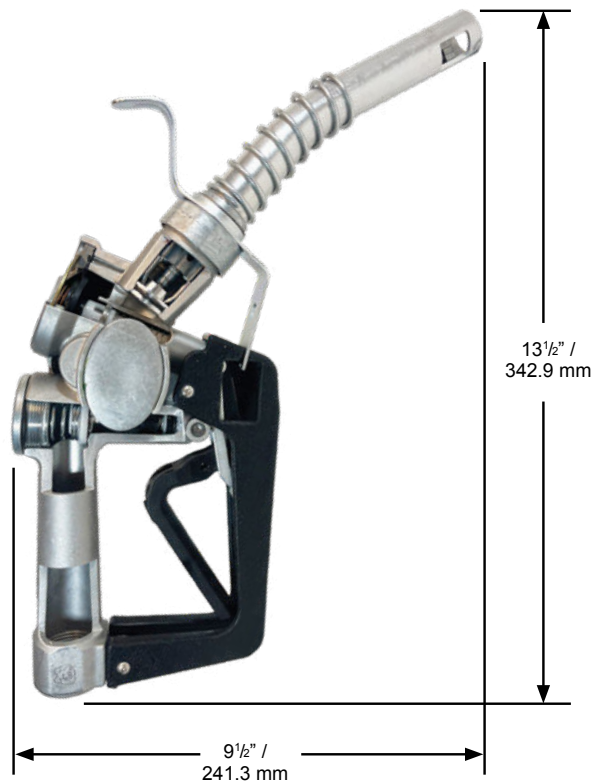

Construction

Body	One piece die cast aluminum with high-impact polymer handguard
Seals	Fluorocarbon
Packing	Double o-ring seal protected by fiber-reinforced Teflon [®]
Lever	One piece polymer
Inlet	3/4" (19 mm) NPT or 3/4" (19 mm) BSP

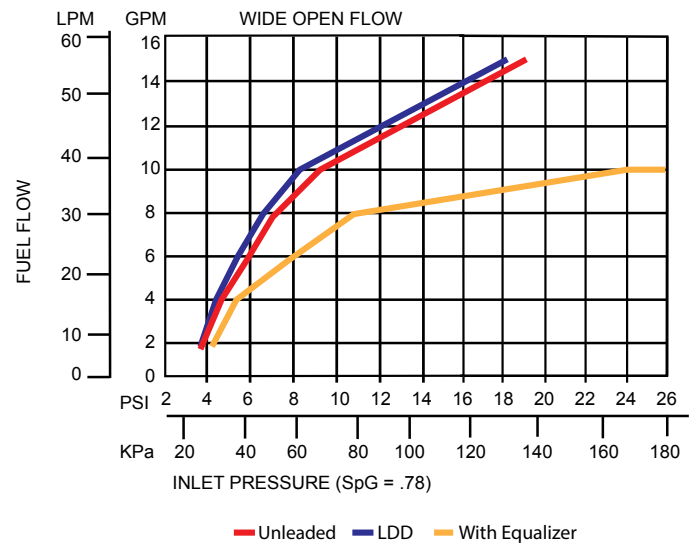

Automatic shut-off nozzle for farm, 12V skid tanks and consumer pump applications.

Nozzle Options

Nozzle Guard Options



Full Grip Guard

POPD®S Full Grip Guard

POPD®H Full Grip Guard

Mate Guard

POPD®S Mate Guard

POPD®H Mate Guard

Waffle Guard Options



1807 Waffle Guard



1808 Waffle Guard

Handguard Options



Standard Polymer Handguard

Gilbarco Polymer Handguard
(with or without Magnet)

Tokheim Polymer Handguard
(with or without Magnet)

Wayne Polymer Handguard
(with or without Magnet)

Lever Options



Lever without Hold Open Clip



Lever with Hold Open Clip

Latch Plate Options



1 - Position Latch Plate

XFS® Nozzles

Automatic shut-off nozzle for farm, 12V skid tanks and consumer pump applications.

System Options

Safe-T-Breaks®

MODEL NO.	DESCRIPTION
002273	3/4" F x 3/4" F NPT Non-Reconnectable Safe-T-Break®
002774	3/4" F x 3/4" F BSPP Non-Reconnectable Safe-T-Break®
003360	3/4" F x 3/4" F NPT Reconnectable Safe-T-Break®
003385	3/4" F x 3/4" F BSPP Reconnectable Safe-T-Break®
005230	3/4" F x 3/4" F NPT Low Pull Reconnectable Safe-T-Break®
006130	3/4" F x 3/4" F NPT Non-Reconnectable PCC Safe-T-Break®
008330	3/4" F x 3/4" F NPT Reconnectable MAGBREAK®
009910	3/4" F x 3/4" F BSPP Reconnectable MAGBREAK®
010328	3/4" F x 3/4" F NPT Reconnectable High Pull MAGBREAK®
010330	3/4" F x 3/4" F BSPP Reconnectable High Pull MAGBREAK®
002774A	3/4" F x 3/4" F BSPP Non-Reconnectable Safe-T-Break® - Atex
003385A	3/4" F x 3/4" F BSPP Reconnectable Safe-T-Break® - Atex

Swivel/Safe-T-Break® Combos

MODEL NO.	DESCRIPTION
006310	3/4" M NPT Multi-Plane Swivel connected to 3/4" F NPT Reconnectable Safe-T-Break®
007085	3/4" M BSPP Multi-Plane Swivel connected to 3/4" F BSPP Reconnectable Safe-T-Break®
007085A	3/4" M BSPP Multi-Plane Swivel connected to 3/4" F BSPP Reconnectable Safe-T-Break® - Atex

Spouts

MODEL NO.	DESCRIPTION
001471	Light Duty Diesel Spout
001473	Unleaded Spout
010353	Light Duty Diesel Long Spout
010434	Unleaded Long Spout

Pressure/Vacuum Vents

MODEL NO.	DESCRIPTION
004620	2" Slip-On Pressure Vacuum Vent
004885	2" Thread-On Pressure Vacuum Vent - NPT
005885	2" Thread-On Pressure Vacuum Vent with Internal Screen - NPT

Accessories, Testing and Maintenance

MODEL NO.	DESCRIPTION
000397	Unleaded Spout Gauge
003593	Hold Open Clip Kit
004490	Conventional Flo-Equalizer® - 10 gpm / 37.9 Lpm
007089	Nozzle Service Kit
007490	Internal Flo-Equalizer® - 10 gpm / 37.9 Lpm

Swivels

MODEL NO.	DESCRIPTION
000350	3/4" M x 3/4" F NPT Multi-Plane Swivel
000355	3/4" M x 3/4" F NPT Multi-Plane Swivel Anodized Black
002272	3/4" M x 3/4" F NPT 90° Pump Swivel
002771	3/4" M x 3/4" F BSPP 90° Pump Swivel
002950	3/4" M x 3/4" F NPT Multi-Plane Restricted Swivel
003590	3/4" M x 3/4" F BSPP Multi-Plane Swivel
003895	3/4" M x 3/4" F NPT Inline Swivel
002771A	3/4" M x 3/4" F BSPP 90° Pump Swivel - Atex
003590A	3/4" M x 3/4" F BSPP Multi-Plane Swivel - Atex

Guards

MODEL NO.	DESCRIPTION
001506	Protection Package
001806	Full Grip Reguard
001807	Waffle Splash Guard with Small Hole
001808	Waffle Splash Guard
001809	Reguard Protection Package
003440	Mate Easy-On Package
003795	Mate Guard
004145	Full Grip Guard
006628	POPD® S Clear Cover
006665	POPD® S Full Grip Guard
007205	POPD® S Full Grip Reguard
007361	Black Handle Cover
007999	POPD® H Clear Cover
008165	POPD® S Mate Guard
008166	POPD® H Mate Guard
008175	POPD® EZS Nozzle Guard
008176	POPD® EZH Nozzle Guard
008185	POPD® H Full Grip Guard
008192	POPD® H Full Grip Reguard
014524	International Mate Package
014530	International Mate Guard
015247	International POPD® H Mate Guard
015253	International POPD® H Mate Package

Guard Color Chart

COLOR	SUFFIX	COLOR	SUFFIX	COLOR <i>CUSTOM</i>	SUFFIX
Blue	-01	Gold	-08	Amoco Blue	-07 <i>CUSTOM</i>
Red	-02	Silver	-09	Apple Green	-18 <i>CUSTOM</i>
Green	-03	BP Green	-16	Purple	-19 <i>CUSTOM</i>
Black	-04	M Blue	-21	Pink	-20 <i>CUSTOM</i>
Yellow	-05	Orange	-39	BPS Green	-22 <i>CUSTOM</i>
White	-06				

Scuff Guards are to be ordered with the corresponding guard color option added to the model number. Example: If BLUE guards are desired, add guard color option -01 to the model number (159504-01). For custom colors, a minimum order of 4,000 guards will be required.

1GS Nozzles

Automatic shut-off nozzle with polymer handguard for farm, 12V skid tanks, large pumps with or without air eliminators and commercial applications.

- 1GS nozzle shuts off when the gas tank is full.
- Stainless steel reinforced spout bushing keeps unleaded and light duty diesel spout tip round, and acts as a captive fastener to prevent tip-end sensor damage.
- Nozzle is equipped with a unique Flo-Stop® device that shuts off the nozzle if it falls from the fill neck or raises above the horizontal.
- Unleaded and light duty diesel *StreamShaper*® reduces turbulence for straighter fuel flow and less splash back spillage.
- Comes standard with smooth full grip guard and hanging hook.
- Not for use with gravity tanks.
- Not legal for retail dispensing applications.
- ADA-compliant EZ Lever reduces the force required to open the main poppet valve by 50%, resulting in a lever operating force ≤5 lbs.



MODEL NO.
045707

New Unleaded PHG Nozzles with NPT Inlet

MODEL NO.	DESCRIPTION	SHIPPING WEIGHT LBS (KG)
045708	without Hold Open Clip, with Polymer Handguard	3.3 (1.4)
045704N^	with Two Notch Open Clip and Polymer Handguard	3.3 (1.4)
045704NR^	with Two Notch Open Clip and Polymer Handguard - in Retail Packaging	3.3 (1.4)
0457209N^	with Two Notch Hold Open Clip, Polymer Handguard and 385 Reducer Bushing	3.4 (1.5)

^ NOT LISTED

New Light Duty Diesel PHG Nozzles with NPT Inlet

MODEL NO.	DESCRIPTION	SHIPPING WEIGHT LBS (KG)
045707	without Hold Open Clip, with Polymer Handguard	3.3 (1.4)
045703N^	with Two Notch Open Clip and Polymer Handguard	3.3 (1.4)
045703NR^	with Two Notch Open Clip and Polymer Handguard - in Retail Packaging	3.3 (1.4)
0457208N^	with Two Notch Hold Open Clip, Polymer Handguard and 385 Reducer Bushing	3.4 (1.5)

^ NOT LISTED

New Light Duty Diesel PHG Nozzles with BSP Inlet

MODEL NO.	DESCRIPTION	SHIPPING WEIGHT LBS (KG)
045715N^	with Two Notch Open Clip and Polymer Handguard	3.3 (1.4)

^ NOT LISTED

New Heavy Duty Diesel PHG Nozzles with NPT Inlet

MODEL NO.	DESCRIPTION	SHIPPING WEIGHT LBS (KG)
045712	without Hold Open Clip, with Polymer Handguard	3.3 (1.4)
1096212	without Hold Open Clip, with Polymer Handguard and Cold Weather Seals	3.3 (1.4)
045709N^	with Two Notch Hold Open Clip, Polymer Handguard and 385 Reducer Bushing, without Flo-Stop®	3.4 (1.5)
045710N^	with Two Notch Open Clip and Polymer Handguard	3.3 (1.4)
045710NR^	with Two Notch Open Clip and Polymer Handguard - in Retail Packaging	3.3 (1.4)
1096210N^	with Two Notch Hold Open Clip, Polymer Handguard and Cold Weather Seals	3.3 (1.4)

^ NOT LISTED

New Heavy Duty Diesel PHG Nozzles with BSP Inlet

MODEL NO.	DESCRIPTION	SHIPPING WEIGHT LBS (KG)
045738N^	with Two Notch Open Clip and Polymer Handguard	3.3 (1.4)

^ NOT LISTED



! WARNING: Cancer and Reproductive Harm - www.P65Warnings.ca.gov

1GS Nozzles

Automatic shut-off nozzle with polymer handguard for farm, 12V skid tanks, large pumps with or without air eliminators and commercial applications.

Dimensions

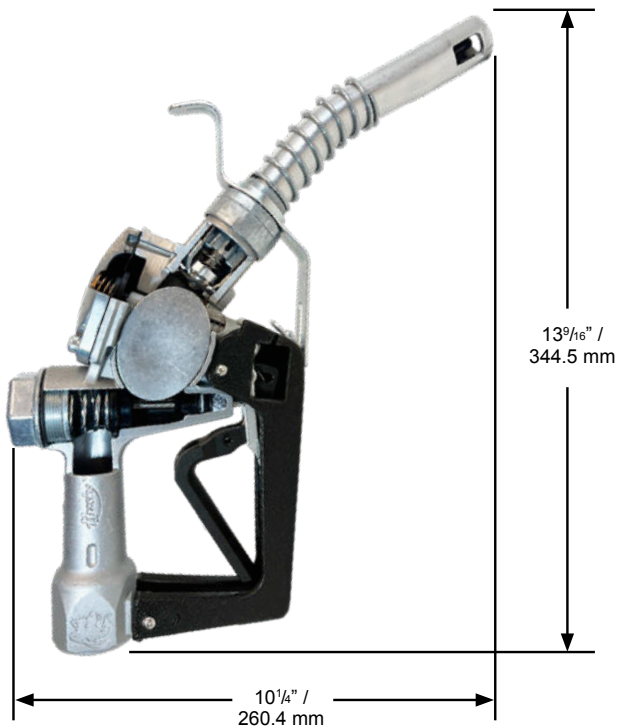

New Unleaded MHG Nozzles with NPT Inlet

MODEL NO.	DESCRIPTION	SHIPPING WEIGHT LBS (KG)
696204N [^]	with Two Notch Open Clip and Metal Handguard	3.4 (1.5)
6962209N [^]	with Two Notch Hold Open Clip, Metal Handguard and 385 Reducer Bushing	3.5 (1.6)

[^] NOT LISTED

New Light Duty Diesel MHG Nozzles with NPT Inlet

MODEL NO.	DESCRIPTION	SHIPPING WEIGHT LBS (KG)
696203N [^]	with Two Notch Open Clip and Metal Handguard	3.4 (1.5)
6962208N [^]	with Two Notch Hold Open Clip, Metal Handguard and 385 Reducer Bushing	3.5 (1.6)

[^] NOT LISTED

New Heavy Duty Diesel MHG Nozzles with NPT Inlet

MODEL NO.	DESCRIPTION	SHIPPING WEIGHT LBS (KG)
696210N [^]	with Two Notch Open Clip and Metal Handguard	3.4 (1.5)

[^] NOT LISTED

New Heavy Duty Diesel MHG Nozzles with BSP Inlet

MODEL NO.	DESCRIPTION	SHIPPING WEIGHT LBS (KG)
696238N [^]	with Two Notch Open Clip and Metal Handguard	3.4 (1.5)

[^] NOT LISTED

Construction

Body	One piece die cast aluminum with high-impact polymer or metal handguard
Seals	Fluorocarbon
Packing	Double o-ring seal protected by fiber-reinforced Teflon [®]
Lever	Two-piece polymer EZ Lever
Inlet	1" (25.4 mm) NPT or 1" (25.4 mm) BSP

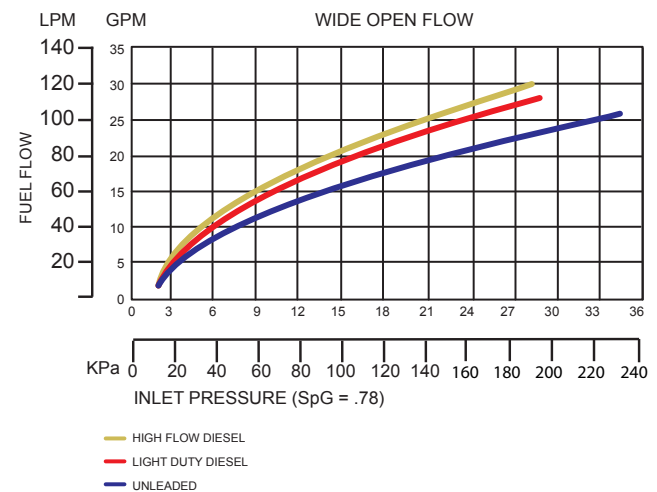

1GS Nozzles

Automatic shut-off nozzle with polymer handguard for farm, 12V skid tanks, large pumps with or without air eliminators and commercial applications.

Nozzle Options

Nozzle Guard Options



Full Grip Guard

POPD[®]S Full Grip Guard

POPD[®]H Full Grip Guard

Mate Guard

POPD[®]S Mate Guard

POPD[®]H Mate Guard

Waffle Guard Options



1808 Waffle Guard

Reducer Bushing



000385

Handguard Options



Standard Polymer Handguard

Standard Metal Handguard

Gilbarco Polymer Handguard

(with or without Magnet)

Tokheim Polymer Handguard

(with or without Magnet)

Wayne Polymer Handguard

(with or without Magnet)

Latch Plate Options

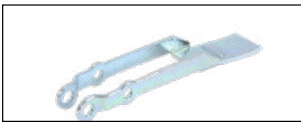

1 - Position Latch Plate



2 - Position Latch Plate

Lever Options



Lever without Hold Open Clip



Lever with Hold Open Clip

Hook Options



Nozzle with Hanging Hook



Nozzle without Hanging Hook

1GS Nozzles

Automatic shut-off nozzle with polymer handguard for farm, 12V skid tanks, large pumps with or without air eliminators and commercial applications.

System Options

Safe-T-Breaks®

MODEL NO.	DESCRIPTION
002276	1" F x 1" F NPT Reconnectable Safe-T-Break®
003076	1" F x 1" F BSPP Reconnectable Safe-T-Break®
003076A	1" F x 1" F BSPP Reconnectable Safe-T-Break® - Atex
005231	1" F x 1" F Low Pull NPT Reconnectable Safe-T-Break®
005812	1" F x 1" F NPT Non-Reconnectable Safe-T-Break®
006301	1" F x 1" F NPT Non-Reconnectable PCC Safe-T-Break®
006914	1" F x 1" F BSPP Non-Reconnectable Safe-T-Break®
008331	1" F x 1" F NPT CK Reconnectable MAGBREAK®
009911	1" F x 1" F BSPP Reconnectable G2 MAGBREAK®

Swivel/Safe-T-Break® Combos

MODEL NO.	DESCRIPTION
005969	1" M NPT Multi-Plane Swivel connected to 1" F NPT Reconnectable Safe-T-Break®
008015	1" M BSPP Multi-Plane Swivel connected to 1" F BSPP Reconnectable Safe-T-Break®
008015A	1" M BSPP Multi-Plane Swivel connected to 1" F BSPP Reconnectable Safe-T-Break® - Atex Spouts

Spouts

MODEL NO.	DESCRIPTION
001471	Light Duty Diesel Spout
001473	Unleaded Spout
005215	Heavy Duty Diesel Spout
010432	Unleaded Long Spout
012263	Light Duty Diesel Long Spout

Pressure/Vacuum Vents

MODEL NO.	DESCRIPTION
004620	2" Slip-On Pressure Vacuum Vent
004885	2" Thread-On Pressure Vacuum Vent - NPT
005885	2" Thread-On Pressure Vacuum Vent with Internal Screen - NPT

Accessories, Testing and Maintenance

MODEL NO.	DESCRIPTION
000385	1" M x 3/4" F Reducer Bushing
000397	Unleaded Spout Gauge
000548	Hanging Hook for Unleaded and Light Duty Diesel Nozzles
003593	Hold Open Clip Kit
007089	Nozzle Service Kit

Swivels

MODEL NO.	DESCRIPTION
000087	1" M x 1" F NPT Multi-Plane Swivel
000095	1" M x 1" F NPT 70° Multi-Plane Swivel
000352	1" M x 3/4" F NPT Multi-Plane Swivel
000356	1" M x 3/4" F NPT Multi-Plane Swivel Anodized Black
003306	1" M x 1" F BSPP Multi-Plane Swivel
003306A	1" M x 1" F BSPP Multi-Plane Swivel - Atex
003395	1" M x 1" F NPT Multi-Plane Restricted Swivel
004860	1" M x 1" F NPT Multi-Plane High Volume Swivel
006949	1" M x 1" F BSPP Multi-Plane High Volume Swivel

Guards

MODEL NO.	DESCRIPTION
000099	Protection Package
000226	Mate Nozzle Guard
000554	Full Grip Guard
001804	Full Grip Reguard
001808	Waffle Splash Guard
001811	Reguard Protection Package
005494	Lever Guard
006628	POPD® S Clear Cover
006655	POPD® S Full Grip Guard
007210	POPD® S Full Grip Reguard
007295	Mate Handle Guard
007999	POPD® H Clear Cover
008169	POPD® S Mate Nozzle Guard
008170	POPD® H Mate Nozzle Guard
008179	POPD® EZS Nozzle Guard
008180	POPD® EZH Nozzle Guard
008183	POPD® H Full Grip Guard
008190	POPD® H Full Grip Reguard

Guard Color Chart

COLOR	SUFFIX	COLOR	SUFFIX	COLOR <i>CUSTOM</i>	SUFFIX
Blue	-01	Gold	-08	Amoco Blue	-07 <i>CUSTOM</i>
Red	-02	Silver	-09	Apple Green	-18 <i>CUSTOM</i>
Green	-03	BP Green	-16	Purple	-19 <i>CUSTOM</i>
Black	-04	M Blue	-21	Pink	-20 <i>CUSTOM</i>
Yellow	-05	Orange	-39	BPS Green	-22 <i>CUSTOM</i>
White	-06				

Scuff Guards are to be ordered with the corresponding guard color option added to the model number. Example: If BLUE guards are desired, add guard color option -01 to the model number (159504-01). For custom colors, a minimum order of 4,000 guards will be required.

1GSS Nozzles

Pressure-activated, automatic shut-off nozzle with polymer handguard for farm, 12V skid tanks, large pumps with or without air eliminators and commercial applications.

- 1GSS nozzle shuts off when:
 - the pump shuts off.
 - the gas tank is full.
 - the lever is opened before the pump is turned on.
 - the leak detector has not completed the test cycle.
- Comes standard with smooth full grip guard and hanging hook
- Not for use with gravity tanks.
- Not legal for retail dispensing applications.
- ADA-compliant EZ Lever reduces the force required to open the main poppet valve by 50%, resulting in a lever operating force ≤5 lbs.
- Stainless steel reinforced spout bushing keeps unleaded and light duty diesel spout tip round, and acts as a captive fastener to prevent tip-end sensor damage.
- Nozzle is equipped with a unique Flo-Stop® device that shuts off the nozzle if it falls from the fill neck or raises above the horizontal
- Unleaded and light duty diesel *StreamShaper*® reduces turbulence for straighter fuel flow and less splash back spillage.



MODEL NO.
1216503

New Unleaded PHG Nozzles with NPT Inlet

MODEL NO.	DESCRIPTION	SHIPPING WEIGHT LBS (KG)
1216504	with Two Notch Hold Open Clip and Polymer Handguard	3.3 (1.4)

New Light Duty Diesel PHG Nozzles with NPT Inlet

MODEL NO.	DESCRIPTION	SHIPPING WEIGHT LBS (KG)
1216503	with Two Notch Hold Open Clip and Polymer Handguard	3.3 (1.4)

New Heavy Duty Diesel PHG Nozzles with NPT Inlet

MODEL NO.	DESCRIPTION	SHIPPING WEIGHT LBS (KG)
1216510	with Two Notch Hold Open Clip and Polymer Handguard	3.3 (1.4)



 WARNING: Cancer and Reproductive Harm - www.P65Warnings.ca.gov

1GSS Nozzles

Pressure-activated, automatic shut-off nozzle with polymer handguard for farm, 12V skid tanks, large pumps with or without air eliminators and commercial applications.

Dimensions

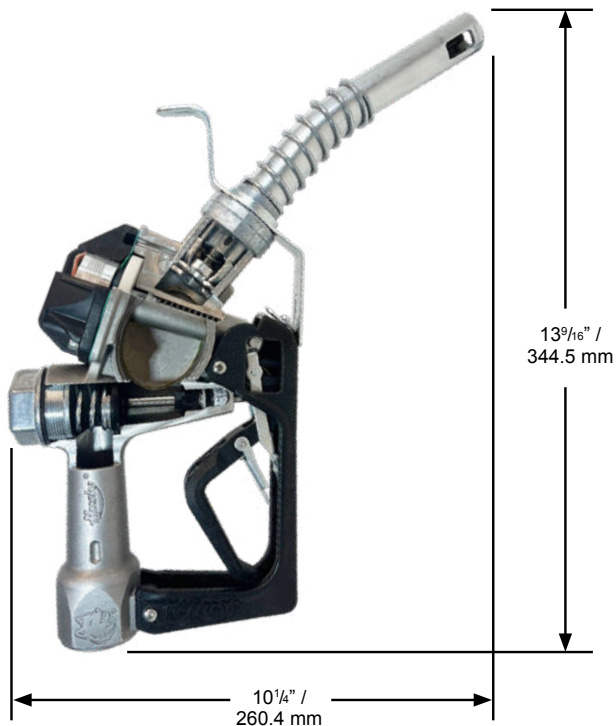

New Unleaded MHG Nozzles with NPT Inlet

MODEL NO.	DESCRIPTION	SHIPPING WEIGHT LBS (KG)
1216804	with Two Notch Hold Open Clip and Metal Handguard	3.5 (1.6)

New Light Duty Diesel MHG Nozzles with NPT Inlet

MODEL NO.	DESCRIPTION	SHIPPING WEIGHT LBS (KG)
1216803	with Two Notch Hold Open Clip and Metal Handguard	3.5 (1.6)

New Heavy Duty Diesel MHG Nozzles with NPT Inlet

MODEL NO.	DESCRIPTION	SHIPPING WEIGHT LBS (KG)
1216810	with Two Notch Hold Open Clip and Metal Handguard	3.3 (1.4)

Construction

Body	One piece die cast aluminum with high-impact polymer or metal handguard
Seals	Fluorocarbon
Packing	Double o-ring seal protected by fiber-reinforced Teflon®
Lever	Two-piece polymer EZ Lever
Inlet	1" (25.4 mm) NPT or 1" (25.4 mm) BSP

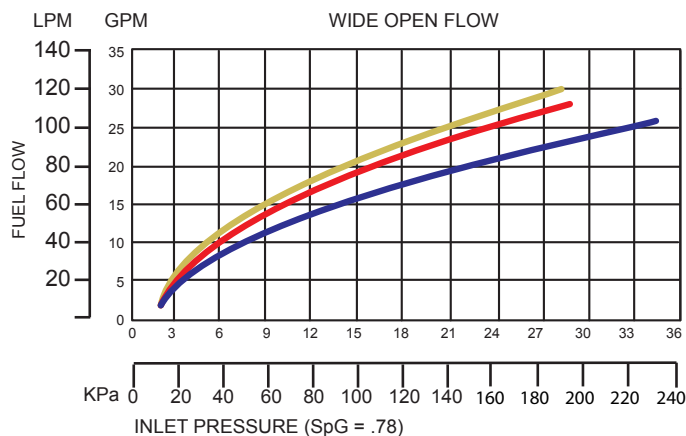

1GSS Nozzles

Pressure-activated, automatic shut-off nozzle with polymer handguard for farm, 12V skid tanks, large pumps with or without air eliminators and commercial applications.

Nozzle Options

Nozzle Guard Options



Full Grip Guard

POPD®S Full Grip Guard

POPD®H Full Grip Guard

Mate Guard

POPD®S Mate Guard

POPD®H Mate Guard

Waffle Guard Options

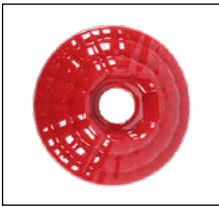

1808 Waffle Guard

Handguard Options



Standard Polymer Handguard

Standard Metal Handguard

Gilbarco Polymer Handguard

Tokheim Polymer Handguard (with or without Magnet)

Wayne Polymer Handguard (with or without Magnet)

Latch Plate Options

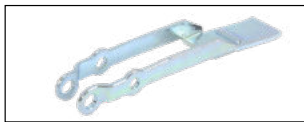

1 - Position Latch Plate

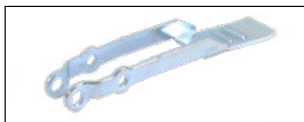

2 - Position Latch Plate

Lever Options



Lever without Hold Open Clip



Lever with Hold Open Clip

Hook Options



Nozzle with Hanging Hook



Nozzle without Hanging Hook

1GSS Nozzles

Pressure-activated, automatic shut-off nozzle with polymer handguard for farm, 12V skid tanks, large pumps with or without air eliminators and commercial applications.

System Options

Safe-T-Breaks®

MODEL NO.	DESCRIPTION
002276	1" F x 1" F NPT Reconnectable Safe-T-Break®
003076	1" F x 1" F BSPP Reconnectable Safe-T-Break®
003076A	1" F x 1" F BSPP Reconnectable Safe-T-Break® - Atex
005231	1" F x 1" F Low Pull NPT Reconnectable Safe-T-Break®
005812	1" F x 1" F NPT Non-Reconnectable Safe-T-Break®
006301	1" F x 1" F NPT Non-Reconnectable PCC Safe-T-Break®
006914	1" F x 1" F BSPP Non-Reconnectable Safe-T-Break®
008331	1" F x 1" F NPT CK Reconnectable MAGBREAK®
009911	1" F x 1" F BSPP Reconnectable G2 MAGBREAK®

Swivel/Safe-T-Break® Combos

MODEL NO.	DESCRIPTION
005969	1" M NPT Multi-Plane Swivel connected to 1" F NPT Reconnectable Safe-T-Break®
008015	1" M BSPP Multi-Plane Swivel connected to 1" F BSPP Reconnectable Safe-T-Break®
008015A	1" M BSPP Multi-Plane Swivel connected to 1" F BSPP Reconnectable Safe-T-Break® - Atex Spouts

Spouts

MODEL NO.	DESCRIPTION
001471	Light Duty Diesel Spout
001473	Unleaded Spout
005215	Heavy Duty Diesel Spout
010432	Unleaded Long Spout
012263	Light Duty Diesel Long Spout

Pressure/Vacuum Vents

MODEL NO.	DESCRIPTION
004620	2" Slip-On Pressure Vacuum Vent
004885	2" Thread-On Pressure Vacuum Vent - NPT
005885	2" Thread-On Pressure Vacuum Vent with Internal Screen - NPT

Accessories, Testing and Maintenance

MODEL NO.	DESCRIPTION
000385	1" M x 3/4" F Reducer Bushing
000397	Unleaded Spout Gauge
000548	Hanging Hook for Unleaded and Light Duty Diesel Nozzles
003593	Hold Open Clip Kit
007089	Nozzle Service Kit

Swivels

MODEL NO.	DESCRIPTION
000087	1" M x 1" F NPT Multi-Plane Swivel
000095	1" M x 1" F NPT 70° Multi-Plane Swivel
000352	1" M x 3/4" F NPT Multi-Plane Swivel
000356	1" M x 3/4" F NPT Multi-Plane Swivel Anodized Black
003306	1" M x 1" F BSPP Multi-Plane Swivel
003306A	1" M x 1" F BSPP Multi-Plane Swivel - Atex
003395	1" M x 1" F NPT Multi-Plane Restricted Swivel
004860	1" M x 1" F NPT Multi-Plane High Volume Swivel
006949	1" M x 1" F BSPP Multi-Plane High Volume Swivel

Guards

MODEL NO.	DESCRIPTION
001807	Waffle Splash Guard with Smaller Hole
001808	Waffle Splash Guard
005494	Lever Guard
007295	Mate Handle Guard
012164	Full Grip Guard

Guard Color Chart

COLOR	SUFFIX	COLOR	SUFFIX	COLOR <i>CUSTOM</i>	SUFFIX
Blue	-01	Gold	-08	Amoco Blue	-07 <i>CUSTOM</i>
Red	-02	Silver	-09	Apple Green	-18 <i>CUSTOM</i>
Green	-03	BP Green	-16	Purple	-19 <i>CUSTOM</i>
Black	-04	M Blue	-21	Pink	-20 <i>CUSTOM</i>
Yellow	-05	Orange	-39	BPS Green	-22 <i>CUSTOM</i>
White	-06				

Scuff Guards are to be ordered with the corresponding guard color option added to the model number. Example: If BLUE guards are desired, add guard color option -01 to the model number (159504-01). For custom colors, a minimum order of 4,000 guards will be required.



Diesel Exhaust Fluid Nozzles



SST DEF Nozzles

Automatic shut-off Diesel Exhaust Fluid (DEF) nozzle for full-service and self-service stations.

- SST DEF nozzle shuts off when tank is full.
- Comes standard with mate nozzle guard and handle cover.
- Modular design for easy cleaning.
- Stainless Steel construction.
- Constructed from materials 100% compatible with Diesel Exhaust Fluid (DEF).
- Available with magnetic Accufuel® safety feature.
- Equipped with a unique Flo-Stop® device that shuts off the nozzle if it falls from the fill tank or raises above the horizontal.



MODEL NO.
731004N

DEF Nozzles with 1" BSPP

MODEL NO.	DESCRIPTION	SHIPPING WEIGHT LBS (KG)
731004N [^]	with Two Notch Hold Open Clip;	4.6 (2.1)
731091N [^]	with Two Notch Hold Open Clip, Spout Ring and magnetic Accufuel® Spout	4.6 (2.1)

[^] NOT LISTED

DEF Nozzles with M34

MODEL NO.	DESCRIPTION	SHIPPING WEIGHT LBS (KG)
1043691N [^]	with Two Notch Hold Open Clip, Spout Ring, magnetic Accufuel® Spout, and Waffle Guard	4.6 (2.1)

[^] NOT LISTED



SST DEF Nozzles

Automatic shut-off Diesel Exhaust Fluid (DEF) nozzle for full-service and self-service stations.

Dimensions

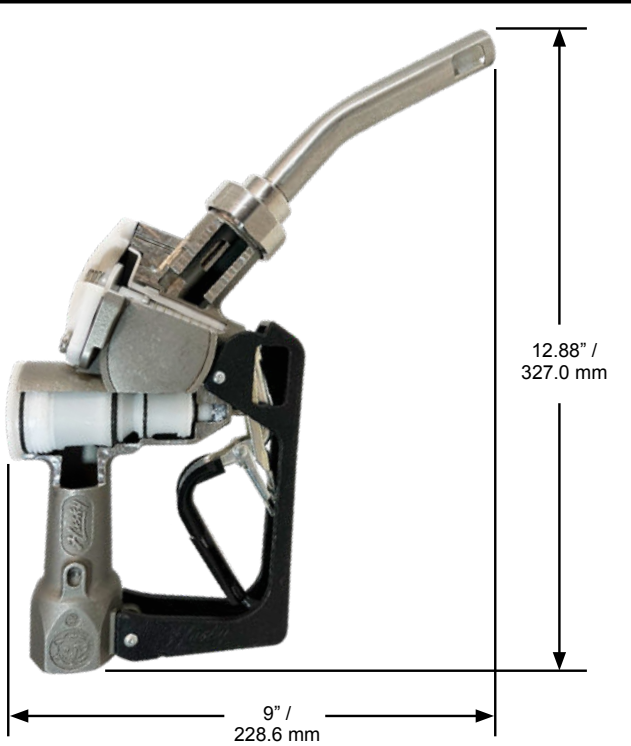

Construction

Body	Investment Cast Stainless Steel
Seals	Fluorocarbon
Packing	Double o-ring seal protected by fiber reinforced Teflon®
Lever	One piece contoured steel with hard plastic cover
Inlet	1" / 25.4 mm BSPP or M34 x 1.5

SST DEF NOZZLE AVERAGE BACK PRESSURE PERFORMANCE VERIFICATION

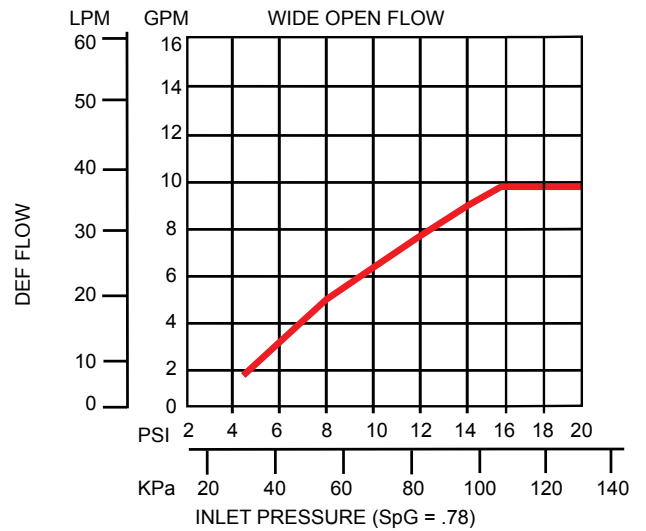

SST DEF Nozzles

Automatic shut-off Diesel Exhaust Fluid (DEF) nozzle for full-service and self-service stations.

Nozzle Options

Nozzle Guard Options



Full Grip Guard

Mate Guard

Handguard Options



Standard Polymer Handguard

Gilbarco Polymer Handguard
(with or without Magnet)

Tokheim Polymer Handguard
(with or without Magnet)

Wayne Polymer Handguard
(with or without Magnet)

Lever Options

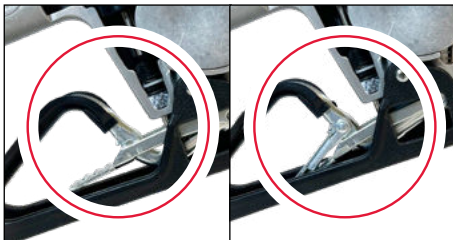

Lever without Hold Open Clip

Lever with Hold Open Clip

Waffle Guard Options



1808 Waffle Guard

Latch Plate Options

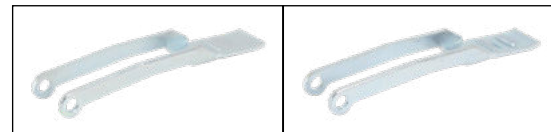

1 - Position Latch Plate

2 - Position Latch Plate

SST DEF Nozzles

Automatic shut-off Diesel Exhaust Fluid (DEF) nozzle for full-service and self-service stations.

System Options

Safe-T-Breaks®

MODEL NO.	DESCRIPTION
007219	1" M x 1" M BSPP Non-Reconnectable Stainless Steel Safe-T-Break®
008216	1" M x 1" M BSPP Reconnectable Stainless Steel Safe-T-Break®

Swivels

MODEL NO.	DESCRIPTION
007269	1" M x 1" M BSPP Inline Swivel
007275	1" M BSPP x M34 M Inline Swivel
007282	3/4" M BSPP x 3/4" Hose Barb Roller Bearing Inline Swivel
007467	1" F x 1" M BSPP Inline Swivel
008510	1" M BSPP 1" F NPT Inline Swivel
010936	3/4" M BSPP X 3/4" Hose Barb Inline Swivel

Spouts

MODEL NO.	DESCRIPTION
007360	with Spout Ring and Flo-Stop®
007362	with Flo-Stop®
007364	with Spout Ring and Magnetic Accufuel® Safety Feature

Guards

MODEL NO.	DESCRIPTION
000226	Mate Nozzle Guard
000554	Full Grip Guard
001808	Waffle Splash Guard
007376	Handle Cover (Black)
008429	DEF Handguard Repair Kit

Adaptors

MODEL NO.	DESCRIPTION
007285	1" M x 1" M BSPP Straight Adaptor
007356	1" M BSPP x M M34 Straight Adaptor
008413	1" M BSPP x 3/4" Hose Barb Adaptor with Seal Kit

















Accessories, Testing and Maintenance

MODEL NO.	DESCRIPTION
007150	Poppet Valve / Venturi Cartridge Assembly
007160	Plunger Cartridge Assembly
007163	Loss Motion Diaphragm Cartridge Assembly
007523	1" BSPP Seal Kit Assembly

Swivel/Safe-T-Break® Combos

MODEL NO.	DESCRIPTION
013185	M34 M NPT Multi-Plane Swivel connected to 1" BSP M Reconnectable Safe-T-Break®
014438	1" BSP M Multi-Plane Swivel connected to 1" BSP M Reconnectable Safe-T-Break®

Guard Color Chart

COLOR	SUFFIX	COLOR	SUFFIX	COLOR <i>CUSTOM</i>	SUFFIX
 Blue	-01	 Gold	-08	 Amoco Blue	-07 <i>CUSTOM</i>
 Red	-02	 Silver	-09	 Apple Green	-18 <i>CUSTOM</i>
 Green	-03	 BP Green	-16	 Purple	-19 <i>CUSTOM</i>
 Black	-04	 M Blue	-21	 Pink	-20 <i>CUSTOM</i>
 Yellow	-05	 Orange	-39	 BPS Green	-22 <i>CUSTOM</i>
 White	-06				

Scuff Guards are to be ordered with the corresponding guard color option added to the model number. Example: If BLUE guards are desired, add guard color option -01 to the model number (159504-01). For custom colors, a minimum order of 4,000 guards will be required.

POLY DEF Nozzles

Polymer shut-off Diesel Exhaust Fluid (DEF) nozzle for full-service stations.

- POLY DEF nozzle shuts off when tank is full.
- Lighter than stainless steel nozzles.
- *StreamShaper*® reduces turbulence for straighter fuel flow and less splash back spillage.
- Less expensive than comparable nozzles.
- Stainless steel spout for durability.
- Replaceable stainless steel spout.
- Available with magnetic Accufuel® safety feature.
- ADA-compliant EZ Lever reduces the force required to open the main poppet valve by 50%, resulting in a lever operating force ≤5 lbs.
- Flow characteristics of nozzle reduces crystallization of DEF.
- Complies with ISO Standard 22241-2:2006.

New Polymer DEF Nozzle with 1" BSPP

MODEL NO.	DESCRIPTION	SHIPPING WEIGHT LBS (KG)
873504N^	with Two Notch Hold Open Clip	1.53 (0.7)
873508	without Two Notch Hold Open Clip, Spout Ring and magnetic Accufuel® Spout	1.53 (0.7)
873504NR^	with Two Notch Hold Open Clip and Retail Packaging	1.53 (0.7)
873588N^	with Two Notch Hold Open Clip and Spout Ring	1.53 (0.7)
873591N^	with Two Notch Hold Open Clip, Spout Ring and magnetic Accufuel® Spout	1.53 (0.7)
1202991N^	with Two Notch Hold Open Clip, Spout Ring, magnetic Accufuel® Spout, and Gilbarco Magnetic Hand Guard	1.53 (0.7)



MODEL NO.
873504N



 WARNING: Cancer and Reproductive Harm - www.P65Warnings.ca.gov

POLY DEF Nozzles

Polymer shut-off Diesel Exhaust Fluid (DEF) nozzle for full-service stations.

Dimensions

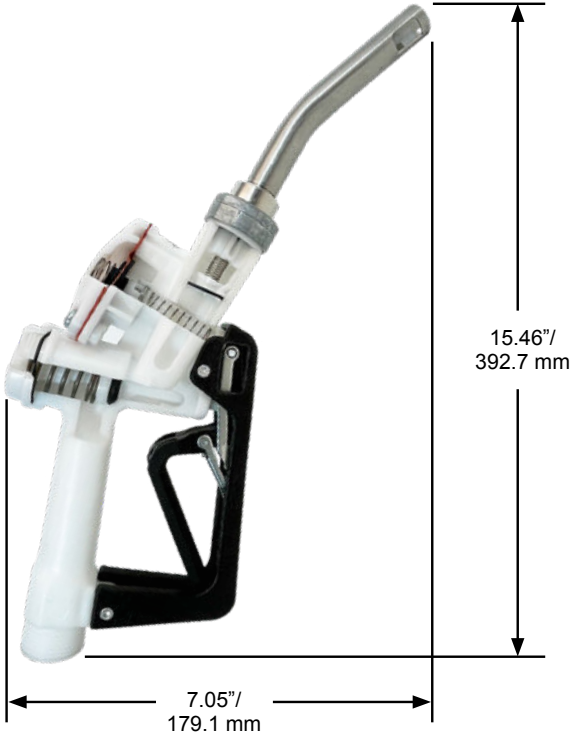

Construction

Body	Investment Cast Stainless Steel
Seals	Fluorocarbon
Spout	19 mm diameter
Packing	Double o-ring seal protected by fiber reinforced Teflon®
Lever	Two piece polymer EZ Lever
Inlet	1" (25.4 mm) BSPP Male Threads or M34 1.5 Male Threads with Face Seal

POLY DEF NOZZLE AVERAGE BACK PRESSURE PERFORMANCE VERIFICATION

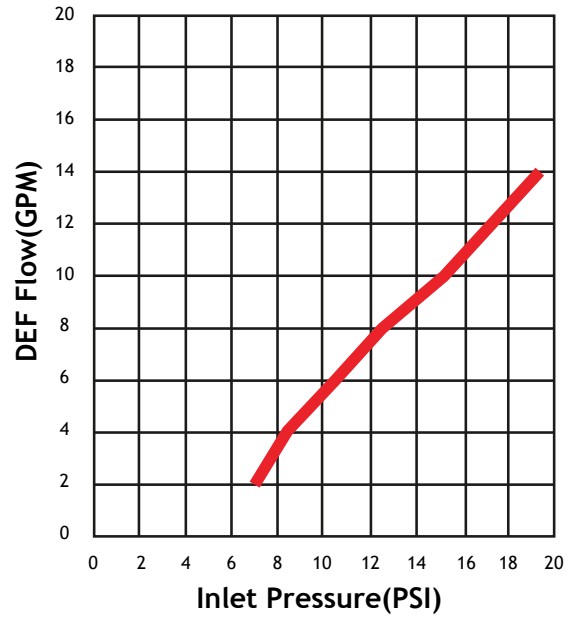

POLY DEF **Nozzles**

Polymer shut-off Diesel Exhaust Fluid (DEF) nozzle for full-service stations.

Nozzle Options

Nozzle Guard Options



Full Grip Guard

Mate Guard

Handguard Options



Standard Polymer Handguard

Gilbarco Polymer Handguard
(with or without Magnet)

Tokheim Polymer Handguard
(with or without Magnet)

Wayne Polymer Handguard
(with or without Magnet)

Lever Options

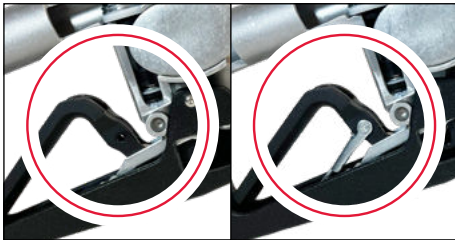

Lever without Hold Open Clip

Lever with Hold Open Clip

Waffle Guard Options



1808 Waffle Guard

Latch Plate Options

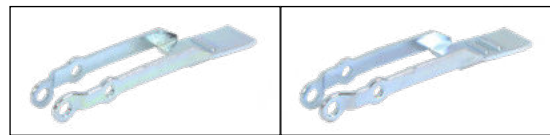

1 - Position Latch Plate

2 - Position Latch Plate

POLY DEF Nozzles

Polymer shut-off Diesel Exhaust Fluid (DEF) nozzle for full-service stations.

System Options

Safe-T-Breaks®

MODEL NO.	DESCRIPTION
007219	1" M x 1" M BSPP Non-Reconnectable Stainless Steel Safe-T-Break®

Swivels

MODEL NO.	DESCRIPTION
007269	1" M x 1" M BSPP Inline Swivel
007275	1" M BSPP x M34 M Inline Swivel
007282	3/4" M BSPP x 3/4" Hose Barb Roller Bearing Inline Swivel
007467	1" F x 1" M BSPP Inline Swivel
008510	1" M BSPP 1" F NPT Inline Swivel
010936	3/4" M BSPP X 3/4" Hose Barb Inline Swivel

Spouts

MODEL NO.	DESCRIPTION
013591	with StreamShaper®
013592	with Spout Ring and StreamShaper®
013593	with Spout Ring and Magnetic Accufuel® Safety Feature

Guards

MODEL NO.	DESCRIPTION
000226	Mate Nozzle Guard
000554	Full Grip Guard
001808	Waffle Splash Guard
007376	Handle Cover (Black)
008429	DEF Handguard Repair Kit

Adaptors

MODEL NO.	DESCRIPTION
007285	1" M x 1" M BSPP Straight Adaptor
007356	1" M BSPP x M M34 Straight Adaptor
008413	1" M BSPP x 3/4" Hose Barb Adaptor with Seal Kit

Accessories, Testing and Maintenance

MODEL NO.	DESCRIPTION
007523	1" BSPP Seal Kit Assembly

Swivel/Safe-T-Break® Combos

MODEL NO.	DESCRIPTION
013185	M34 M NPT Multi-Plane Swivel connected to 1" BSP M Reconnectable Safe-T-Break®
014438	1" BSP M Multi-Plane Swivel connected to 1" BSP M Reconnectable Safe-T-Break®

Guard Color Chart

COLOR	SUFFIX	COLOR	SUFFIX	COLOR <i>CUSTOM</i>	SUFFIX
Blue	-01	Gold	-08	Amoco Blue	-07 <i>CUSTOM</i>
Red	-02	Silver	-09	Apple Green	-18 <i>CUSTOM</i>
Green	-03	BP Green	-16	Purple	-19 <i>CUSTOM</i>
Black	-04	M Blue	-21	Pink	-20 <i>CUSTOM</i>
Yellow	-05	Orange	-39	BPS Green	-22 <i>CUSTOM</i>
White	-06				

Scuff Guards are to be ordered with the corresponding guard color option added to the model number. Example: If BLUE guards are desired, add guard color option -01 to the model number (159504-01). For custom colors, a minimum order of 4,000 guards will be required.

X DEF Nozzles

Automatic shut-off Diesel Exhaust Fluid (DEF) nozzle for full-service and self-service stations.

- X DEF nozzle shuts off when tank is full.
- Lighter than stainless steel nozzles.
- *StreamShaper*® reduces turbulence for straighter fuel flow and less splash back spillage.
- Less expensive than comparable nozzles.
- Tilt poppet design provides precise “to-the-penny” dispensing.
- Stainless steel spout for durability.
- Flow characteristics of nozzle reduces crystallization of DEF.
- Complies with ISO Standard 22241-2:2006.



MODEL NO.
11676155N

New X DEF Nozzle with 3/4" NPT

MODEL NO.	DESCRIPTION	SHIPPING WEIGHT LBS (KG)
11676155N [^]	with Two Notch Hold Open Clip	3.0 (1.3)
11676188N [^]	with Two Notch Hold Open Clip, Spout Ring and Magnetic Accufuel® Spout	3.0 (1.3)
11676189N [^]	with Two Notch Hold Open Clip and Long Spout	3.0 (1.3)
12150155N [^]	with Two Notch Hold Open Clip and Gilbarco Magnetic Handguard	3.0 (1.3)
12970155N [^]	with Two Notch Hold Open Clip and Wayne Magnetic Handguard	3.0 (1.3)

[^] NOT LISTED

New X DEF Nozzle with 3/4" BSPP

MODEL NO.	DESCRIPTION	SHIPPING WEIGHT LBS (KG)
1167691N [^]	with Two Notch Hold Open Clip, Spout Ring and Magnetic Accufuel® Spout	3.0 (1.3)
11676154N [^]	with Two Notch Hold Open Clip	3.0 (1.3)
11676180N [^]	with Two Notch Hold Open Clip without Waffle Guard	3.0 (1.3)
11676190N [^]	with Two Notch Hold Open Clip and Long Spout	3.0 (1.3)
11676290N [^]	with Two Notch Hold Open Clip, Spout Ring and Magnetic Accufuel® Long Spout	3.0 (1.3)
12150154N [^]	with Two Notch Hold Open Clip and Gilbarco Magnetic Handguard	3.0 (1.3)
1215091N [^]	with Two Notch Hold Open Clip, Spout Ring, Magnetic Accufuel® Spout and Gilbarco Magnetic Handguard	3.0 (1.3)
12964154N [^]	with Two Notch Hold Open Clip, and Wayne Magnetic Handguard without Spout Groove	3.0 (1.3)
12970154N [^]	with Two Notch Hold Open Clip and Wayne Magnetic Handguard	3.0 (1.3)
13410204N [^]	with Two Notch Hold Open Clip, without Spout Groove	3.0 (1.3)
11676302N [^]	with Two Notch Hold Open Clip, without Spout Groove and Flo-Equalizer® (3 gpm)	3.0 (1.3)

[^] NOT LISTED



WARNING: Cancer and Reproductive Harm - www.P65Warnings.ca.gov

X DEF Nozzles

Automatic shut-off Diesel Exhaust Fluid (DEF) nozzle for full-service and self-service stations.

Dimensions

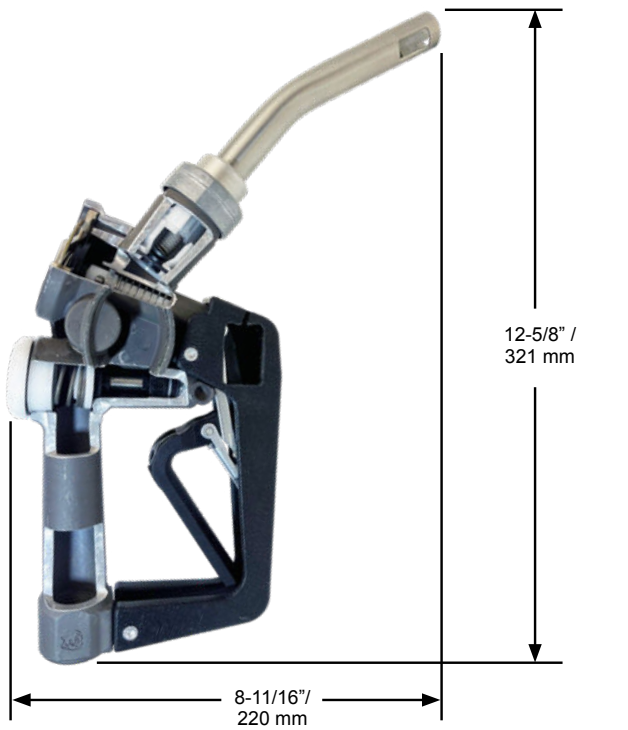

Construction

Body	Anodized Aluminum
Seals	Fluorocarbon
Spout	19 mm diameter
Packing	Double o-ring seal protected by fiber-reinforced Teflon®
Lever	One-piece polymer
Inlet	3/4" / 19 mm NPT or 3/4" / 19 mm BSPP

X DEF NOZZLE AVERAGE BACK PRESSURE PERFORMANCE VERIFICATION

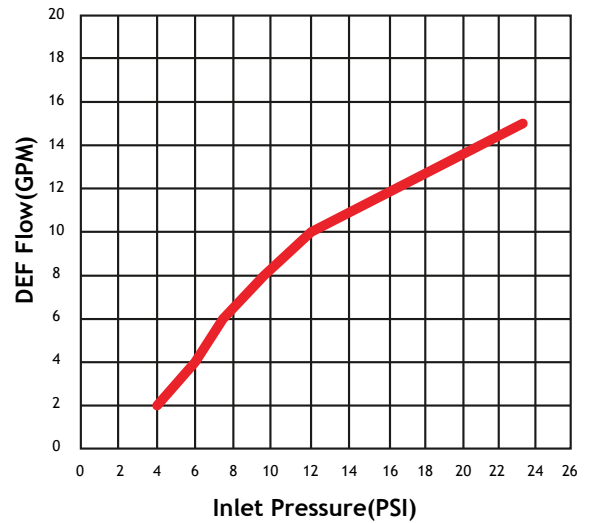

X DEF Nozzles

Automatic shut-off Diesel Exhaust Fluid (DEF) nozzle for full-service and self-service stations.

Nozzle Options

Nozzle Guard Options



Full Grip Guard

Mate Guard

Handguard Options



Standard Polymer Handguard

Gilbarco Polymer Handguard
(with or without Magnet)

Tokheim Polymer Handguard
(with or without Magnet)

Wayne Polymer Handguard
(with or without Magnet)

Lever Options

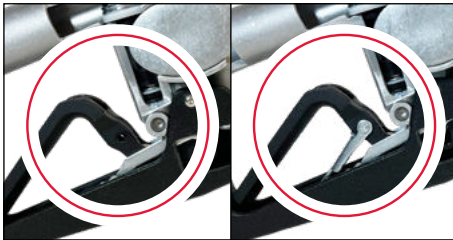

Lever without Hold Open Clip

Lever with Hold Open Clip

Waffle Guard Options



1808 Waffle Guard

Latch Plate Options

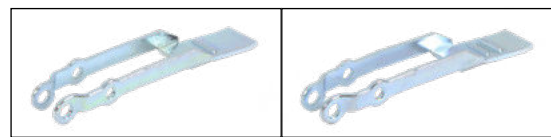

1 - Position Latch Plate

2 - Position Latch Plate

X DEF Nozzles

Automatic shut-off Diesel Exhaust Fluid (DEF) nozzle for full-service and self-service stations.

System Options

Safe-T-Breaks®

MODEL NO.	DESCRIPTION
012070	3/4" F x 3/4" F NPT Reconnectable Safe-T-Break®
012659	3/4" F x 3/4" F BSPP Reconnectable Safe-T-Break®

Swivels

MODEL NO.	DESCRIPTION
007282	3/4" M BSPP x 3/4" Hose Barb Roller Bearing Inline Swivel
010936	3/4" M BSPP x 3/4" Hose Barb Inline Swivel
012604	3/4" M x 3/4" F NPT Roller Bearing Inline Swivel
012656	3/4" M x 3/4" F BSPP Roller Bearing Inline Swivel

Spouts

MODEL NO.	DESCRIPTION
007360	with Spout Ring and Flo-Stop®
007362	with Flo-Stop®
007364	with Spout Ring and Magnetic Accufuel® Safety Feature

Guards

MODEL NO.	DESCRIPTION
001808	Waffle Splash Guard
003795	Mate Nozzle Guard
004145	Full Nozzle Guard
007361	Handle Cover (Black)
014114	International Mate Nozzle Guard

















Accessories, Testing and Maintenance

MODEL NO.	DESCRIPTION
007522	3/4" BSPP Seal Kit Assembly
013285	with StreamShaper®
013286	with Spout Ring and Magnetic Accufuel® Safety Feature
015319	with Long Spout and StreamShaper®

Swivel/Safe-T-Break® Combos

MODEL NO.	DESCRIPTION
012828	3/4" BSP M Multi-Plane Swivel connected to 3/4" BSP F Reconnectable Safe-T-Break®
012831	3/4" NPT M Multi-Plane Swivel connected to 3/4" NPT F Reconnectable Safe-T-Break®
012887	3/4" BSP M Multi-Plane Swivel connected to 1" BSP F Reconnectable Safe-T-Break®
012890	3/4" BSP M Multi-Plane Swivel connected to 1" BSP M Reconnectable Safe-T-Break®

Guard Color Chart

COLOR	SUFFIX	COLOR	SUFFIX	COLOR <i>CUSTOM</i>	SUFFIX
 Blue	-01	 Gold	-08	 Amoco Blue	-07 <i>CUSTOM</i>
 Red	-02	 Silver	-09	 Apple Green	-18 <i>CUSTOM</i>
 Green	-03	 BP Green	-16	 Purple	-19 <i>CUSTOM</i>
 Black	-04	 M Blue	-21	 Pink	-20 <i>CUSTOM</i>
 Yellow	-05	 Orange	-39	 BPS Green	-22 <i>CUSTOM</i>
 White	-06				

Scuff Guards are to be ordered with the corresponding guard color option added to the model number. Example: If BLUE guards are desired, add guard color option -01 to the model number (159504-01). For custom colors, a minimum order of 4,000 guards will be required.



Conventional Ethanol Fueling Nozzles

XS[®] E25 Nozzles

CONVENTIONAL ETHANOL FUELING

Pressure-activated, automatic shut-off nozzle for full-service and self-service stations.

- XS E25 nozzle shuts off when:
 - the pump shuts off.
 - the gas tank is full.
 - the lever is opened before the pump is turned on.
 - the leak detector has not completed the test cycle.
- Stainless steel reinforced spout bushing keeps spout tip round, and acts as a captive fastener to prevent tip-end sensor damage.
- Nozzle is equipped with a unique Flo-Stop[®] device that shuts off the nozzle if it falls from the fill neck or raises above the horizontal.
- *StreamShaper*[®] reduces turbulence for straighter fuel flow and less splash back spillage.
- New poppet seal design in conjunction with new tilt poppet design improves flow control (“to-the-penny” dispensing) and provides enhanced endurance over time.
- Optional cold weather seals are rated to -40° F/C.
- Optional Gilbarco, Tokheim, and Wayne handguards can be fitted with a magnet to trigger the dispenser’s proximity switch, or can be provided without the magnet for dispensers equipped with a standard “flapper” switch.
- All seals are UL approved fluorocarbon compounds to prevent degradation from Ethanol blends.
- Compatible with unleaded and all Ethanol blends through E-25.
- Comes standard with smooth full grip guard.
- ADA-compliant EZ Lever reduces the force required to open the main poppet valve by 50%, resulting in a lever operating force ≤5 lbs.



MODEL NO. 1108459

New Unleaded Nozzles with NPT Inlet

MODEL NO.	DESCRIPTION	SHIPPING WEIGHT LBS (KG)
1108459	with Two Notch Hold Open Clip, 1808 Waffle Splash Guard and Cold Weather Seals	3.1 (1.4)
1108689	with Single Notch Hold Open Clip, POPD's and 1808 Waffle Splash Guard	3.2 (1.5)
11086179	with Single Notch Hold Open Clip and 1808 Waffle Splash Guard	3.1 (1.4)
1108659	with Two notch hold open clip and 1808 Waffle Splash Guard	3.1 (1.4)
E1108604	with Two Notch Hold Open Clip, Mate Guard and Polymer Handle Cover	3.0 (1.4)
E1108659	with Two Notch Hold Open Clip, Mate Guard, Polymer Handle Cover and 1808 Waffle Splash Guard	3.1 (1.4)



WARNING: Cancer and Reproductive Harm - www.P65Warnings.ca.gov

XS[®] E25 Nozzles

Pressure-activated, automatic shut-off nozzle for full-service and self-service stations.

Dimensions

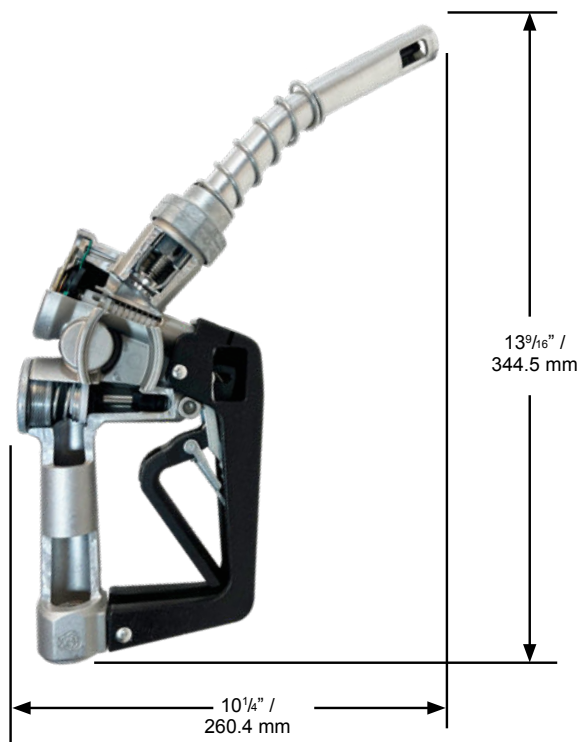

Construction

Body	Die cast aluminum with high-impact polymer handguard
Seals	Fluorocarbon
Packing	Double o-ring seal protected by fiber-reinforced Teflon [®]
Lever	One piece polymer
Inlet	3/4" (19 mm) NPT or 3/4" (19 mm) BSP

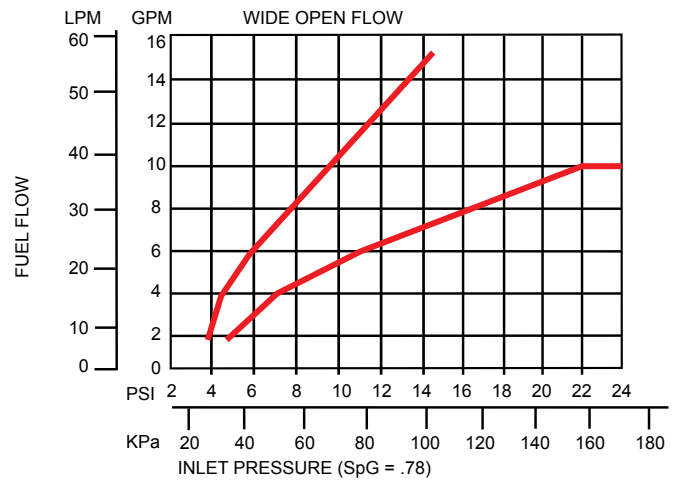

XS[®] E25 Nozzles

Pressure-activated, automatic shut-off nozzle for full-service and self-service stations.

Nozzle Options

Nozzle Guard Options



Waffle Guard Options



Handguard Options



Latch Plate Options

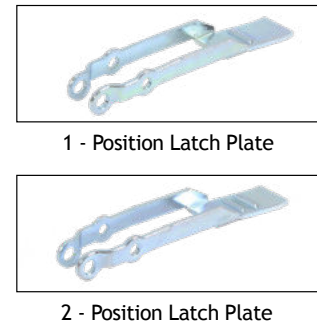

Lever Options

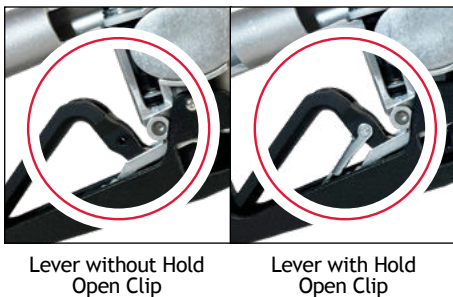

XS[®] E25 Nozzles

Pressure-activated, automatic shut-off nozzle for full-service and self-service stations.

System Options

Safe-T-Breaks[®]

MODEL NO.	DESCRIPTION
006273	3/4" F x 3/4" F Non-Reconnectable E85 Safe-T-Break [®] Trebuchet MS
006360 [^]	3/4" F x 3/4" F Reconnectable E25/E85 Safe-T-Break [®]

Spouts

MODEL NO.	DESCRIPTION
006207	Unleaded E85 Spout Assembly

Pressure/Vacuum Vents

MODEL NO.	DESCRIPTION
004620	2" Slip-On Pressure Vacuum Vent
004885	2" Thread-On Pressure Vacuum Vent - NPT
005885	2" Thread-On Pressure Vacuum Vent with Internal Screen - NPT

Accessories, Testing and Maintenance

MODEL NO.	DESCRIPTION
000397	Unleaded Spout Gauge
003593	Hold Open Clip Kit
007089	Nozzle Service Kit
007490	Internal Flo-Equalizer [®] - 10 gpm / 37.9 Lpm

Swivels

MODEL NO.	DESCRIPTION
006350 [^]	3/4" M x 3/4" F NPT Multi-Plane E85 Swivel

Guards

MODEL NO.	DESCRIPTION
001506	Protection Package
001806	Full Grip Reguard
001807	Waffle Splash Guard with Small Hole
001808	Waffle Splash Guard
001809	Reguard Protection Package
003440	Mate Easy-On Package
003795	Mate Guard
004145	Full Grip Guard
006628	POPD [®] S Clear Cover
006665	POPD [®] S Full Grip Guard
007205	POPD [®] S Full Grip Reguard
007361	Black Handle Cover
007999	POPD [®] H Clear Cover
008165	POPD [®] S Mate Guard
008166	POPD [®] H Mate Guard
008175	POPD [®] EZS Nozzle Guard
008176	POPD [®] EZH Nozzle Guard
008185	POPD [®] H Full Grip Guard
008192	POPD [®] H Full Grip Reguard
014524	International Mate Package
014530	International Mate Guard
015247	International POPD [®] H Mate Guard
015253	International POPD [®] H Mate Package

Guard Color Chart

COLOR	SUFFIX	COLOR	SUFFIX	COLOR <i>CUSTOM</i>	SUFFIX
Blue	-01	Gold	-08	Amoco Blue	-07 <i>CUSTOM</i>
Red	-02	Silver	-09	Apple Green	-18 <i>CUSTOM</i>
Green	-03	BP Green	-16	Purple	-19 <i>CUSTOM</i>
Black	-04	M Blue	-21	Pink	-20 <i>CUSTOM</i>
Yellow	-05	Orange	-39	BPS Green	-22 <i>CUSTOM</i>
White	-06				

Scuff Guards are to be ordered with the corresponding guard color option added to the model number. Example: If BLUE guards are desired, add guard color option -01 to the model number (159504-01). For custom colors, a minimum order of 4,000 guards will be required.

X E85 Nozzles

Automatic shut-off nozzle for full-service and self-service stations.

- X E85 nozzle shuts off when the gas tank is full.
- Stainless steel reinforced spout bushing keeps spout tip round, and acts as a captive fastener to prevent tip-end sensor damage.
- Nozzle is equipped with a unique Flo-Stop® device that shuts off the nozzle if it falls from the fill neck or raises above the horizontal.
- StreamShaper® reduces turbulence for straighter fuel flow and less splash back spillage.
- Aluminum body, spout, and internal parts are nickel plated to prevent contamination and corrosion from Ethanol blends.
- New poppet seal design in conjunction with new tilt poppet design improves flow control (“to-the-penny” dispensing) and provides enhanced endurance over time.
- Optional cold weather seals are rated to -40° F/C.
- Optional Gilbarco, Tokheim, and Wayne handguards can be fitted with a magnet to trigger the dispenser’s proximity switch, or can be provided without the magnet for dispensers equipped with a standard “flapper” switch.
- All seals are UL approved fluorocarbon compounds to prevent degradation from Ethanol blends.
- Compatible with unleaded and all Ethanol blends through E-85.
- Comes standard with smooth full grip guard.
- ADA-compliant EZ Lever reduces the force required to open the main poppet valve by 50%, resulting in a lever operating force ≤5 lbs.



MODEL NO.
659404N

New Unleaded Nozzles with NPT Inlet

MODEL NO.	DESCRIPTION	SHIPPING WEIGHT LBS (KG)
659404N [^]	with Two Notch Hold Open Clip	2.9 (1.3)
659459N [^]	with Two Notch Hold Open Clip and 1808 Waffle Splash Guard	3.0 (1.4)
659495N [^]	with Two Notch Hold Open Clip, POPD® S and 1808 Waffle Splash Guard	3.0 (1.4)

[^] NOT LISTED



⚠ WARNING: Cancer and Reproductive Harm - www.P65Warnings.ca.gov

X E85 Nozzles

Automatic shut-off nozzle for full-service and self-service stations.

Dimensions

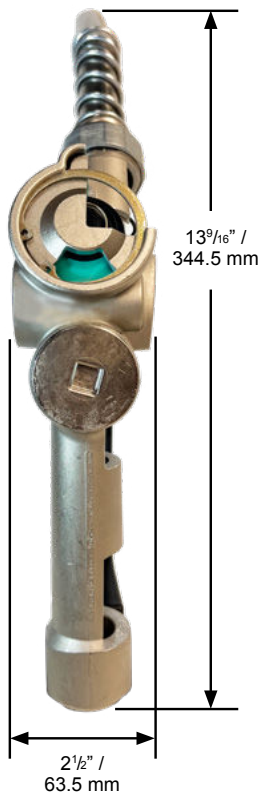
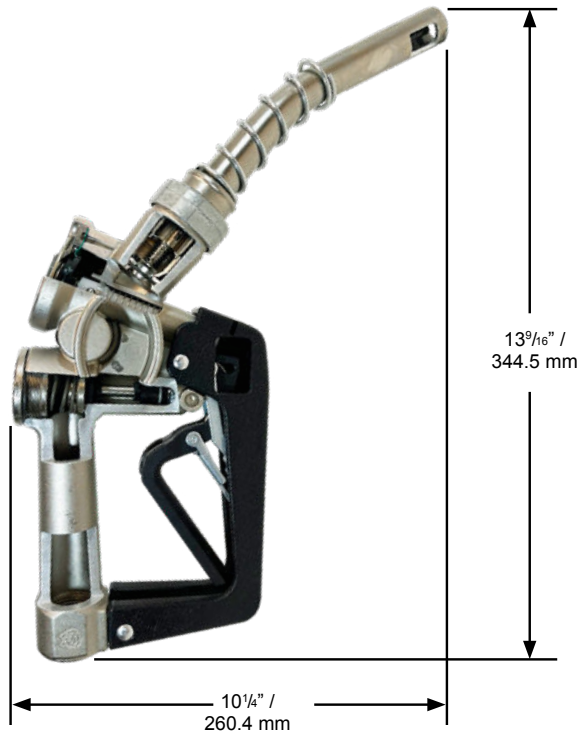

Construction

Body	Nickel-plated die cast aluminum with high-impact polymer handguard
Seals	Fluorocarbon
Packing	Double o-ring seal protected by fiber-reinforced Teflon®
Lever	Two piece polymer EZ Lever
Inlet	3/4" (19 mm) NPT or 3/4" (19 mm) BSP

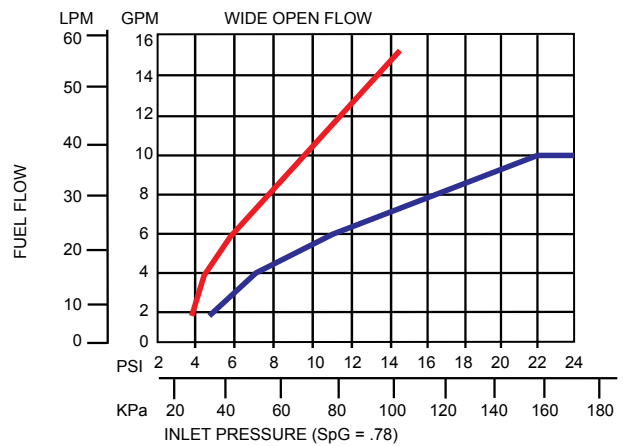

X E85 Nozzles

Automatic shut-off nozzle for full-service and self-service stations.

Nozzle Options

Nozzle Guard Options



Waffle Guard Options



Handguard Options

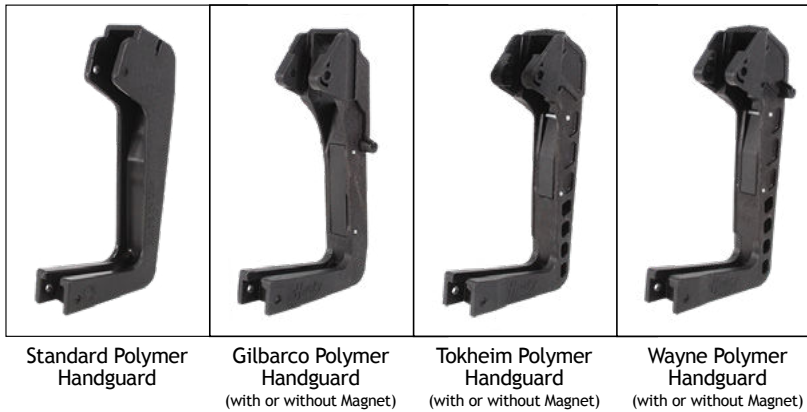

Latch Plate Options

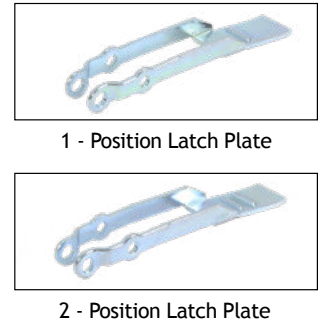

Lever Options

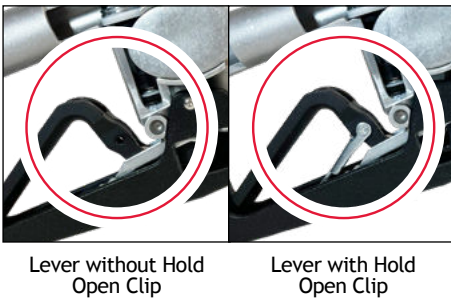

X E85 Nozzles

Automatic shut-off nozzle for full-service and self-service stations.

System Options

Safe-T-Breaks®

MODEL NO.	DESCRIPTION
006273	3/4" F x 3/4" F Non-Reconnectable E85 Safe-T-Break® Trebuchet MS
006360^	3/4" F x 3/4" F Reconnectable E25/E85 Safe-T-Break®

Spouts

MODEL NO.	DESCRIPTION
006207	Unleaded E85 Spout Assembly

Pressure/Vacuum Vents

MODEL NO.	DESCRIPTION
004620	2" Slip-On Pressure Vacuum Vent
004885	2" Thread-On Pressure Vacuum Vent - NPT
005885	2" Thread-On Pressure Vacuum Vent with Internal Screen - NPT

Accessories, Testing and Maintenance

MODEL NO.	DESCRIPTION
000397	Unleaded Spout Gauge
003593	Hold Open Clip Kit
007089	Nozzle Service Kit
007490	Internal Flo-Equalizer® - 10 gpm / 37.9 Lpm

Swivels

MODEL NO.	DESCRIPTION
006350^	3/4" M x 3/4" F NPT Multi-Plane E85 Swivel

Guards

MODEL NO.	DESCRIPTION
001506	Protection Package
001806	Full Grip Reguard
001807	Waffle Splash Guard with Small Hole
001808	Waffle Splash Guard
001809	Reguard Protection Package
003440	Mate Easy-On Package
003795	Mate Guard
004145	Full Grip Guard
006628	POPD® S Clear Cover
006665	POPD® S Full Grip Guard
007205	POPD® S Full Grip Reguard
007361	Black Handle Cover
007999	POPD® H Clear Cover
008165	POPD® S Mate Guard
008166	POPD® H Mate Guard
008175	POPD® EZS Nozzle Guard
008176	POPD® EZH Nozzle Guard
008185	POPD® H Full Grip Guard
008192	POPD® H Full Grip Reguard
014524	International Mate Package
014530	International Mate Guard
015247	International POPD® H Mate Guard
015253	International POPD® H Mate Package

Guard Color Chart

COLOR	SUFFIX	COLOR	SUFFIX	COLOR <i>CUSTOM</i>	SUFFIX
Blue	-01	Gold	-08	Amoco Blue	-07 <i>CUSTOM</i>
Red	-02	Silver	-09	Apple Green	-18 <i>CUSTOM</i>
Green	-03	BP Green	-16	Purple	-19 <i>CUSTOM</i>
Black	-04	M Blue	-21	Pink	-20 <i>CUSTOM</i>
Yellow	-05	Orange	-39	BPS Green	-22 <i>CUSTOM</i>
White	-06				

Scuff Guards are to be ordered with the corresponding guard color option added to the model number. Example: If BLUE guards are desired, add guard color option -01 to the model number (159504-01). For custom colors, a minimum order of 4,000 guards will be required.

XS[®] E85 Nozzles

CONVENTIONAL ETHANOL FUELING

Pressure-activated, automatic shut-off nozzle for full-service and self-service stations.

- XS E85 nozzle shuts off when:
 - the pump shuts off.
 - the gas tank is full.
 - the lever is opened before the pump is turned on.
 - the leak detector has not completed the test cycle.
- Stainless steel reinforced spout bushing keeps spout tip round, and acts as a captive fastener to prevent tip-end sensor damage.
- Nozzle is equipped with a unique Flo-Stop[®] device that shuts off the nozzle if it falls from the fill neck or raises above the horizontal.
- *StreamShaper*[®] reduces turbulence for straighter fuel flow and less splash back spillage.
- Aluminum body, spout, and internal parts are nickel plated to prevent contamination and corrosion from Ethanol blends.
- New poppet seal design in conjunction with new tilt poppet design improves flow control (“to-the-penny” dispensing) and provides enhanced endurance over time.
- Optional cold weather seals are rated to -40° F/C.
- Optional Gilbarco, Tokheim, and Wayne handguards can be fitted with a magnet to trigger the dispenser’s proximity switch, or can be provided without the magnet for dispensers equipped with a standard “flapper” switch.
- All seals are UL approved fluorocarbon compounds to prevent degradation from Ethanol blends.
- Compatible with unleaded and all Ethanol blends through E-85.
- Comes standard with smooth full grip guard.
- ADA-compliant EZ Lever reduces the force required to open the main poppet valve by 50%, resulting in a lever operating force ≤5 lbs.



MODEL NO.
659504

New Unleaded Nozzles with NPT Inlet

MODEL NO.	DESCRIPTION	SHIPPING WEIGHT LBS (KG)
659504	with Two Notch Hold Open Clip	3.0 (1.4)
659559	with Two Notch Hold Open Clip and 1808 Waffle Splash Guard	3.1 (1.4)
659589	with Single Notch Hold Open Clip, POPD [®] S and 1808 Waffle Splash Guard	3.2 (1.5)
666164	with Two Notch Hold Open Clip, 1808 Waffle Splash Guard and Cold Weather Seals	3.1 (1.4)
6595179	with Single Notch Hold Open Clip and 1808 Waffle Splash Guard	3.1 (1.4)
E659504	with Two Notch Hold Open Clip and Mate Guard	3.0 (1.4)
E659559	with Two Notch Hold Open Clip, Mate Guard and 1808 Waffle Splash Guard	3.1 (1.4)
E659595	with Two Notch Hold Open Clip, POPD [®] S Mate Guard and 1808 Waffle Splash Guard	3.1 (1.5)

^ NOT LISTED



WARNING: Cancer and Reproductive Harm - www.P65Warnings.ca.gov

XS[®] E85 Nozzles

Pressure-activated, automatic shut-off nozzle for full-service and self-service stations.

Dimensions

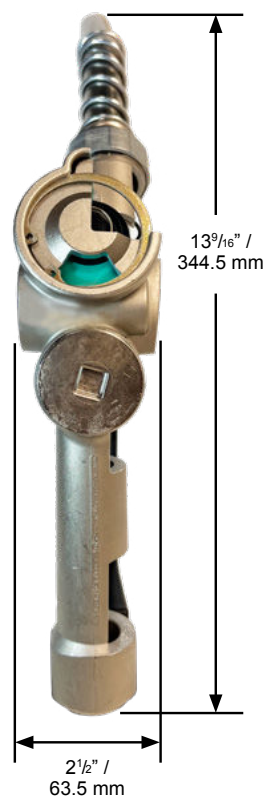
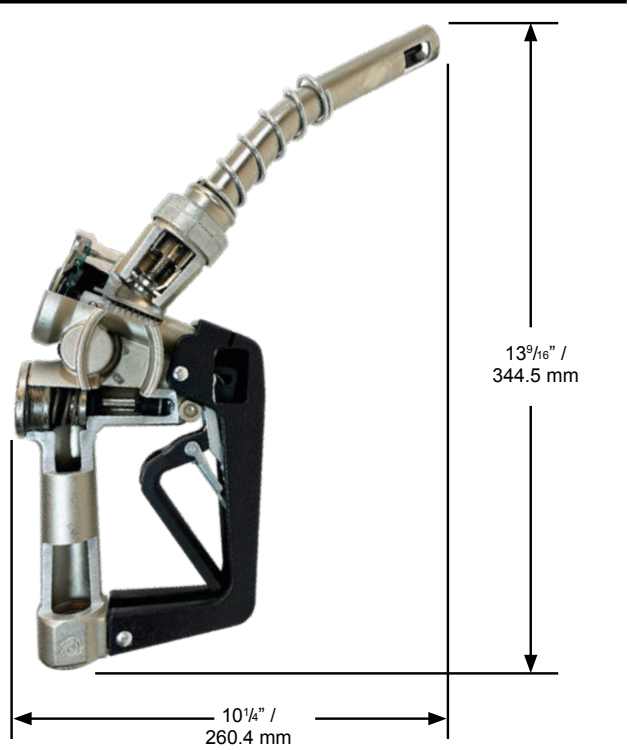

Construction

Body	Nickel-plated die cast aluminum with high-impact polymer handguard
Seals	Fluorocarbon
Packing	Double o-ring seal protected by fiber-reinforced Teflon [®]
Lever	Two piece polymer EZ Lever
Inlet	3/4" (19 mm) NPT or 3/4" (19 mm) BSP

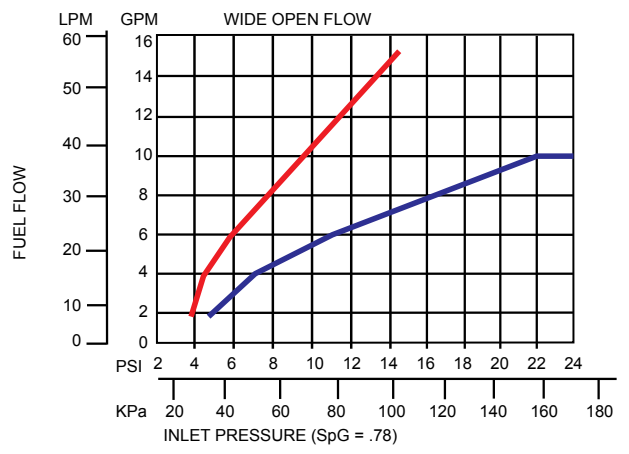

XS[®] E85 Nozzles

Pressure-activated, automatic shut-off nozzle for full-service and self-service stations.

Nozzle Options

Nozzle Guard Options



Waffle Guard Options



Handguard Options



Latch Plate Options

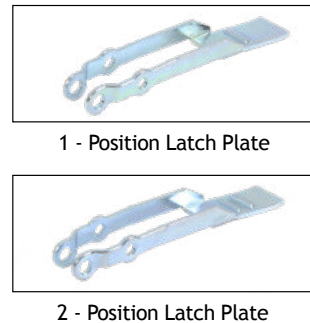

Lever Options

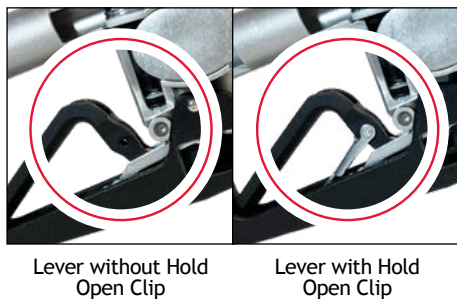

CONVENTIONAL ETHANOL FUELING

XS[®] E85 Nozzles

Pressure-activated, automatic shut-off nozzle for full-service and self-service stations.

System Options

Safe-T-Breaks[®]

MODEL NO.	DESCRIPTION
006273	3/4" F x 3/4" F Non-Reconnectable E85 Safe-T-Break [®] Trebuchet MS
006360 [^]	3/4" F x 3/4" F Reconnectable E25/E85 Safe-T-Break [®]

Spouts

MODEL NO.	DESCRIPTION
006207	Unleaded E85 Spout Assembly

Pressure/Vacuum Vents

MODEL NO.	DESCRIPTION
004620	2" Slip-On Pressure Vacuum Vent
004885	2" Thread-On Pressure Vacuum Vent - NPT
005885	2" Thread-On Pressure Vacuum Vent with Internal Screen - NPT

Accessories, Testing and Maintenance

MODEL NO.	DESCRIPTION
000397	Unleaded Spout Gauge
003593	Hold Open Clip Kit
007089	Nozzle Service Kit
007490	Internal Flo-Equalizer [®] - 10 gpm / 37.9 Lpm

















Swivels

MODEL NO.	DESCRIPTION
006350 [^]	3/4" M x 3/4" F NPT Multi-Plane E85 Swivel

Guards

MODEL NO.	DESCRIPTION
001506	Protection Package
001806	Full Grip Reguard
001807	Waffle Splash Guard with Small Hole
001808	Waffle Splash Guard
001809	Reguard Protection Package
003440	Mate Easy-On Package
003795	Mate Guard
004145	Full Grip Guard
006628	POPD [®] S Clear Cover
006665	POPD [®] S Full Grip Guard
007205	POPD [®] S Full Grip Reguard
007361	Black Handle Cover
007999	POPD [®] H Clear Cover
008165	POPD [®] S Mate Guard
008166	POPD [®] H Mate Guard
008175	POPD [®] EZS Nozzle Guard
008176	POPD [®] EZH Nozzle Guard
008185	POPD [®] H Full Grip Guard
008192	POPD [®] H Full Grip Reguard
014524	International Mate Package
014530	International Mate Guard
015247	International POPD [®] H Mate Guard
015253	International POPD [®] H Mate Package

Guard Color Chart

COLOR	SUFFIX	COLOR	SUFFIX	COLOR <i>CUSTOM</i>	SUFFIX
 Blue	-01	 Gold	-08	 Amoco Blue	-07 <i>CUSTOM</i>
 Red	-02	 Silver	-09	 Apple Green	-18 <i>CUSTOM</i>
 Green	-03	 BP Green	-16	 Purple	-19 <i>CUSTOM</i>
 Black	-04	 M Blue	-21	 Pink	-20 <i>CUSTOM</i>
 Yellow	-05	 Orange	-39	 BPS Green	-22 <i>CUSTOM</i>
 White	-06				

Scuff Guards are to be ordered with the corresponding guard color option added to the model number. Example: If BLUE guards are desired, add guard color option -01 to the model number (159504-01). For custom colors, a minimum order of 4,000 guards will be required.



Vapor Recovery Nozzles

V34 Nozzles

Pressure-activated, automatic shut-off vacuum assist nozzle for full-service and self-service stations.

- V34 nozzle shuts off when:
 - the pump shuts off.
 - the gas tank is full.
 - the lever is opened before the pump is turned on.
 - the leak detector has not completed the test cycle.
- Stainless steel reinforced spout bushing keeps spout tip round, and acts as a captive fastener to prevent tip-end sensor damage.
- Nozzle is equipped with a unique Flo-Stop® device that shuts off the nozzle if it falls from the fill neck or raises above the horizontal.
- *StreamShaper*® reduces turbulence for straighter fuel flow and less splash back spillage.
- Tilt poppet design provides precise “to-the-penny” dispensing.
- Strong vapor valve in the nozzle that is mechanically operated by the on-off action of the nozzle’s lever.
- Husky® vapor return line is an internal part of the body casting, thus eliminating potential vapor leak points and fugitive evaporative emissions from the fuel remaining in the vapor path of the hose.
- Vapor assist achieved at the body end of the spout where a vapor ring catches emissions.
- Uses conventional unleaded spout with spout ring and soft vapor escape guard.

- Nozzle comes standard with a full grip guard.
- Optional cold weather seals are rated to -40° F/C.
- Optional Gilbarco, Tokheim, and Wayne handguards can be fitted with a magnet to trigger the dispenser’s proximity switch, or can be provided without the magnet for dispensers equipped with a standard “flapper” switch.
- Optional vapor insert increases the vapor back pressure, closely matching that of the competition, and making installation a breeze, with little-to-no changes to the vacuum pump draw.
- Optional sightglass provides a clear window for the customer to view the fuel as it passes through the main poppet valve.
- ADA-compliant EZ Lever reduces the force required to open the main poppet valve by 50%, resulting in a lever operating force ≤5 lbs.



MODEL NO.
6250041

New Unleaded PHG Nozzles

MODEL NO.	DESCRIPTION	SHIPPING WEIGHT LBS (KG)
6250041	with Two Notch Hold Open Clip and Vapor Emissions Guard	3.3 (1.5)
6250431	with Single Notch Hold Open Clip and Vapor Emissions Guard	3.3 (1.5)
14373264N^	with Two Notch Hold Open Clip, Vapor Emissions Guard and RFID Spout	3.3 (1.5)

^ NOT LISTED



WARNING: Cancer and Reproductive Harm - www.P65Warnings.ca.gov

V34 Nozzles

Pressure-activated, automatic shut-off vacuum assist nozzle for full-service and self-service stations.

Dimensions

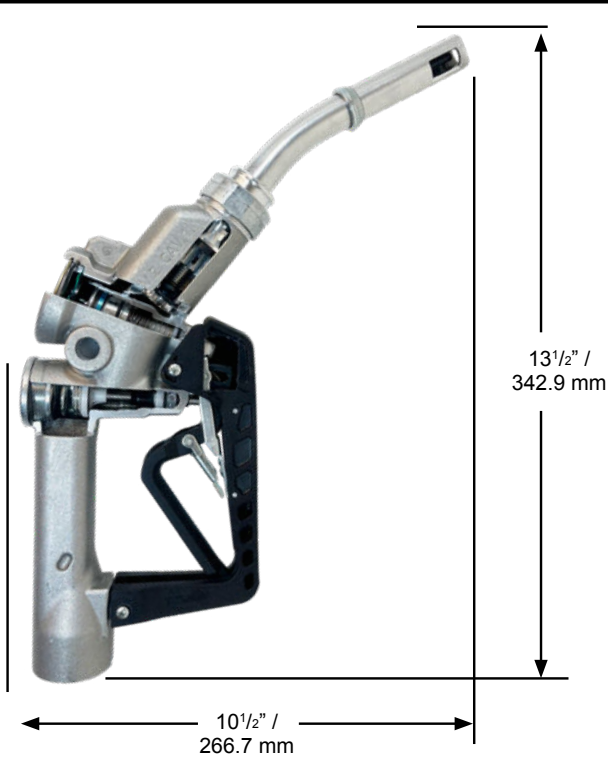

Construction

Body	One piece sand cast aluminum with high-impact polymer handguard
Seals	Fluorocarbon
Packing	Double o-ring seal protected by fiber-reinforced Teflon®
Lever	Two piece polymer EZ Lever
Inlet	M34 x 1.5mm

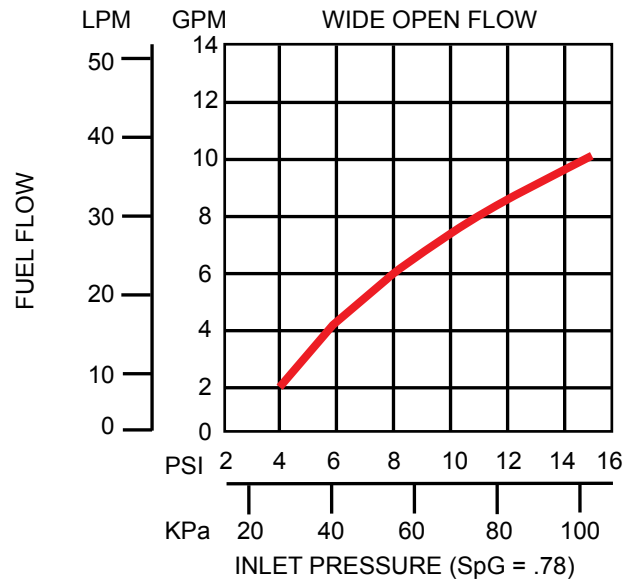
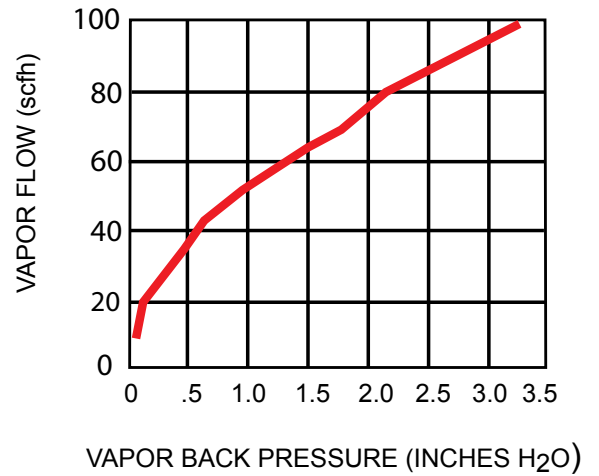

V34 Nozzles

Pressure-activated, automatic shut-off vacuum assist nozzle for full-service and self-service stations.

Nozzle Options

Nozzle Guard Options



Waffle Guard Options



1808 Waffle Guard

Handguard Options



Standard Polymer Handguard

Gilbarco Polymer Handguard
(with or without Magnet)

Tokheim Polymer Handguard
(with or without Magnet)

Wayne Polymer Handguard
(with or without Magnet)

Latch Plate Options

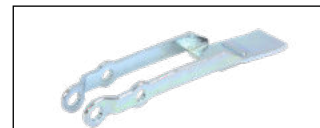

1 - Position Latch Plate



2 - Position Latch Plate

Lever Options

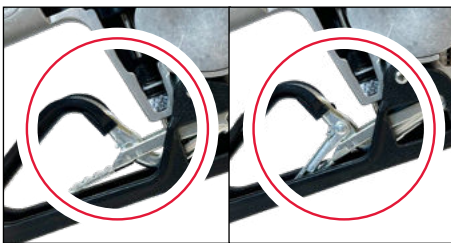

Lever without Hold Open Clip

Lever with Hold Open Clip

TUV Vapor Insert



07329

Sightglass Option



V34 Nozzles

Pressure-activated, automatic shut-off vacuum assist nozzle for full-service and self-service stations.

System Options

Safe-T-Breaks®

MODEL NO.	DESCRIPTION
004034	Reconnectable Safe-T-Break®
004034A*	Reconnectable Safe-T-Break® - Atex
005134A*	Non-Reconnectable Safe-T-Break® - Atex
006210	Non-Reconnectable Safe-T-Break®
008332	MAGBREAK® Coax M34 CK
010513	Non-Reconnectable Safe-T-Break® - Shearpin

Spouts

MODEL NO.	DESCRIPTION
006291	V34 Spout Assy Kit (Includes 004000 VSG and 006391 Spout Assembly)
006391	V34 Spout Assembly with Streamshaper®

Pressure/Vacuum Vents

MODEL NO.	DESCRIPTION
004620	2" Slip-On Pressure Vacuum Vent
004885	2" Thread-On Pressure Vacuum Vent - NPT
005885	2" Thread-On Pressure Vacuum Vent with Internal Screen - NPT

Accessories, Testing and Maintenance

MODEL NO.	DESCRIPTION
000397	Unleaded Spout Gauge
003593	Hold Open Clip Kit
004000	Vapor Splash Guard (VSG) with Clamp
004039	Vapor Splash Guard Clamp
004335	O-ring, Air / Liquid Test Spout Adaptor
004360	Air / Liquid Spout Adaptor
005233	O-ring Kit
005260	Tool for dry Air / Liquid Test
005837	Vapor Assist Flo-Equalizer®
006497	VSG Clamp Tool
006941	Hose Conversion Adaptor M34 x 1.5
007089	Nozzle Service Kit
010073	Waffle VSG with Clamp (single notch V34)
010076	Waffle VSG without Clamp (single notch V34)

Swivels

MODEL NO.	DESCRIPTION
004605	Multi-Plane Swivel
004605A*	Multi-Plane Swivel - Atex

Guards

MODEL NO.	DESCRIPTION
004231	Full Grip Reguard
005494	Lever Guard
006628	POPD® S Clear Cover
006660	POPD® S Full Grip Guard
006951	Full Grip Guard
007220	POPD® S Full Grip Reguard
007999	POPD® H Clear Cover
008184	POPD® H Full Grip Guard
008191	POPD® H Full Grip Reguard
010089	Black Handle Cover
014526	Mate Guard

Guard Color Chart

COLOR	SUFFIX	COLOR	SUFFIX	COLOR <i>CUSTOM</i>	SUFFIX
Blue	-01	Gold	-08	Amoco Blue	-07 <i>CUSTOM</i>
Red	-02	Silver	-09	Apple Green	-18 <i>CUSTOM</i>
Green	-03	BP Green	-16	Purple	-19 <i>CUSTOM</i>
Black	-04	M Blue	-21	Pink	-20 <i>CUSTOM</i>
Yellow	-05	Orange	-39	BPS Green	-22 <i>CUSTOM</i>
White	-06				

Scuff Guards are to be ordered with the corresponding guard color option added to the model number. Example: If BLUE guards are desired, add guard color option -01 to the model number (159504-01). For custom colors, a minimum order of 4,000 guards will be required.

V34 COAX Nozzles

Pressure-activated, automatic shut-off vacuum assist nozzle for full-service and self-service stations.

- V34 COAX nozzle shuts off when:
 - the pump shuts off.
 - the gas tank is full.
 - the lever is opened before the pump is turned on.
 - the leak detector has not completed the test cycle.
- Uses unleaded spout with spout ring, soft vapor splash guard and coaxial design that allows for fuel to be dispensed through the center of the spout while collecting vapors between the inner and outer spout tubes.
- Nozzle is equipped with a unique Flo-Stop® device that shuts off the nozzle if it falls from the fill neck or raises above the horizontal.
- Tilt poppet design provides precise “to-the-penny”
- Strong vapor valve in the nozzle that is mechanically operated by the on-off action of the nozzle’s lever.
- Husky® vapor return line is an internal part of the body casting, thus eliminating potential vapor leak points and fugitive evaporative emissions from the fuel remaining in the vapor path of the hose.
- Nozzle comes standard with a full grip guard.
- Optional cold weather seals are rated to -40° F/C
- Optional Gilbarco, Tokheim, and Wayne handguards can be fitted with a magnet to trigger the dispenser’s proximity switch, or can be provided without the magnet for dispensers equipped with a standard “flapper” switch.
- Optional sightglass provides a clear window for the customer to view the fuel as it passes through the main poppet valve.
- ADA-compliant EZ Lever reduces the force required to open the main poppet valve by 50%, resulting in a lever operating force ≤5 lbs.

New Unleaded PHG Nozzles

MODEL NO.	DESCRIPTION	SHIPPING WEIGHT LBS (KG)
6200041	with Two Notch Hold Open Clip and Vapor Splash Guard	3.3 (1.5)
		[^] NOT LISTED



MODEL NO.
6200041



WARNING: Cancer and Reproductive Harm - www.P65Warnings.ca.gov

V34 COAX Nozzles

Pressure-activated, automatic shut-off vacuum assist nozzle for full-service and self-service stations.

Dimensions

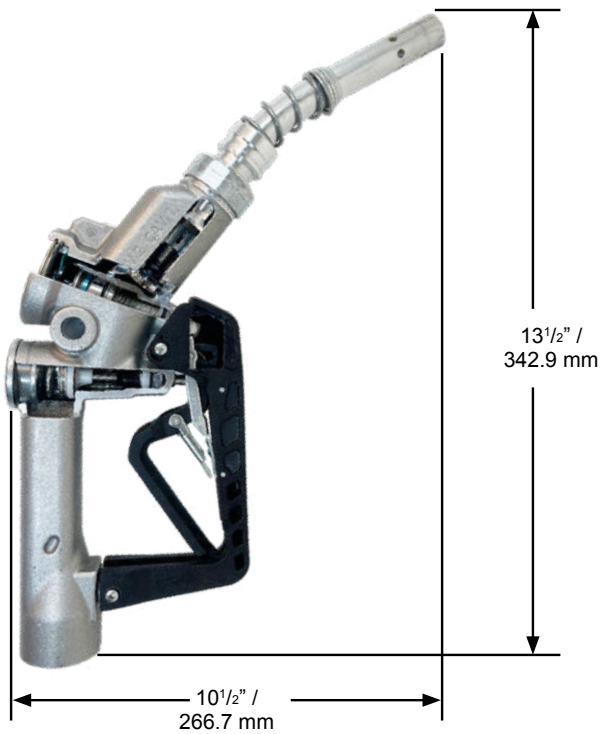

Construction

Body	One piece sand cast aluminum with high-impact polymer handguard
Seals	Fluorocarbon
Packing	Double o-ring seal protected by fiber-reinforced Teflon®
Lever	Two piece polymer EZ Lever
Inlet	M34 x 1.5mm

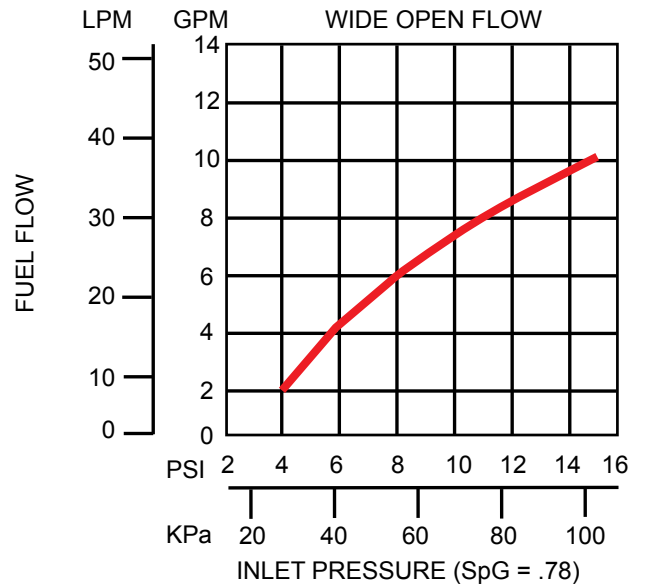
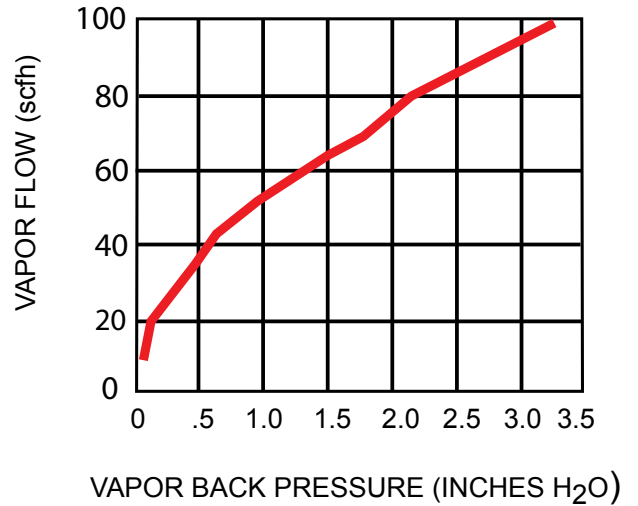

V34 COAX Nozzles

Pressure-activated, automatic shut-off vacuum assist nozzle for full-service and self-service stations.

Nozzle Options

Nozzle Guard Options



Full Grip Guard

POPD®S Full Grip Guard

POPD®H Full Grip Guard

Mate Guard

POPD®S Mate Guard

POPD®H Mate Guard

Handguard Options



Standard Polymer Handguard

Gilbarco Polymer Handguard (with or without Magnet)

Tokheim Polymer Handguard (with or without Magnet)

Wayne Polymer Handguard (with or without Magnet)

Latch Plate Options

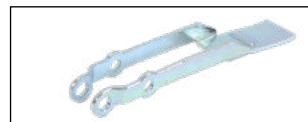

1 - Position Latch Plate

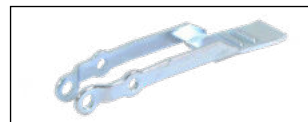

2 - Position Latch Plate

Lever Options

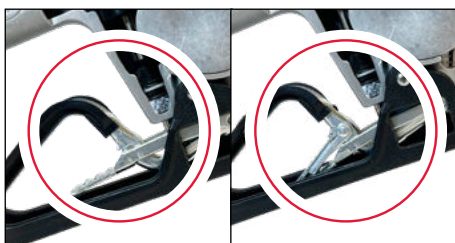

Lever without Hold Open Clip

Lever with Hold Open Clip

Sightglass Option



V34 COAX Nozzles

Pressure-activated, automatic shut-off vacuum assist nozzle for full-service and self-service stations.

System Options

Safe-T-Breaks®

MODEL NO.	DESCRIPTION
004034	Reconnectable Safe-T-Break®
004034A*	Reconnectable Safe-T-Break® - Atex
005134A*	Non-Reconnectable Safe-T-Break® - Atex
006210	Non-Reconnectable Safe-T-Break®
008332	MAGBREAK® Coax M34 CK
010513	Non-Reconnectable Safe-T-Break® - Shearpin

Spouts

MODEL NO.	DESCRIPTION
008642	V34-006200 Coaxial Spout Assembly Kit (Includes 009968 Spout Assembly and 004000 VSG)
009968	V34-006200 Coaxial Spout Assembly

Pressure/Vacuum Vents

MODEL NO.	DESCRIPTION
004620	2" Slip-On Pressure Vacuum Vent
004885	2" Thread-On Pressure Vacuum Vent - NPT
005885	2" Thread-On Pressure Vacuum Vent with Internal Screen - NPT

Accessories, Testing and Maintenance

MODEL NO.	DESCRIPTION
000397	Unleaded Spout Gauge
003593	Hold Open Clip Kit
004000	Vapor Splash Guard (VSG) with Clamp
004039	Vapor Splash Guard Clamp
004335	O-ring, Air / Liquid Test Spout Adaptor
004360	Air / Liquid Spout Adaptor
005233	O-ring Kit
005260	Tool for dry Air / Liquid Test
005837	Vapor Assist Flo-Equalizer®
006497	VSG Clamp Tool
006941	Hose Conversion Adaptor M34 x 1.5
007089	Nozzle Service Kit
010073	Waffle VSG with Clamp (single notch V34)
010076	Waffle VSG without Clamp (single notch V34)

Swivels

MODEL NO.	DESCRIPTION
004605	Multi-Plane Swivel
004605A*	Multi-Plane Swivel - Atex

Guards

MODEL NO.	DESCRIPTION
004231	Full Grip Reguard
005494	Lever Guard
006628	POPD® S Clear Cover
006660	POPD® S Full Grip Guard
006951	Full Grip Guard
007220	POPD® S Full Grip Reguard
007999	POPD® H Clear Cover
008184	POPD® H Full Grip Guard
008191	POPD® H Full Grip Reguard
010089	Black Handle Cover
014526	Mate Guard

Guard Color Chart

COLOR	SUFFIX	COLOR	SUFFIX	COLOR <i>CUSTOM</i>	SUFFIX
Blue	-01	Gold	-08	Amoco Blue	-07 <i>CUSTOM</i>
Red	-02	Silver	-09	Apple Green	-18 <i>CUSTOM</i>
Green	-03	BP Green	-16	Purple	-19 <i>CUSTOM</i>
Black	-04	M Blue	-21	Pink	-20 <i>CUSTOM</i>
Yellow	-05	Orange	-39	BPS Green	-22 <i>CUSTOM</i>
White	-06				

Scuff Guards are to be ordered with the corresponding guard color option added to the model number. Example: If BLUE guards are desired, add guard color option -01 to the model number (159504-01). For custom colors, a minimum order of 4,000 guards will be required.

V34 ORVR Nozzles

Pressure-activated, automatic shut-off vacuum assist nozzle for full-service and self-service stations.

- V34 ORVR nozzle shuts off when:
 - the pump shuts off.
 - the gas tank is full.
 - the lever is opened before the pump is turned on.
 - the leak detector has not completed the test cycle.
- Nozzle designed for the Veeder-Root® 900301 and VST Enviro-Loc® primary hose with ORVR valve.
- Stainless steel reinforced spout bushing keeps spout tip round, and acts as a captive fastener to prevent tip-end sensor damage.
- Nozzle is equipped with a unique Flo-Stop® device that shuts off the nozzle if it falls from the fill neck or raises above the horizontal.
- *StreamShaper*® reduces turbulence for straighter fuel flow and less splash back spillage.
- Tilt poppet design provides precise “to-the-penny” dispensing.
- Strong vapor valve in the nozzle that is mechanically operated by the on-off action of the nozzle’s lever.
- Husky® vapor return line is an internal part of the body casting, thus eliminating potential vapor leak points and fugitive evaporative emissions from the fuel remaining in the vapor path of the hose.
- Vapor assist achieved at the body end of the spout where a vapor ring catches emissions.
- Uses conventional unleaded spout with spout ring and soft vapor escape guard.
- Nozzle comes standard with a full grip guard.
- Optional cold weather seals are rated to -40° F/C.
- Optional Gilbarco, Tokheim, and Wayne handguards can be fitted with a magnet to trigger the dispenser’s proximity switch, or can be provided without the magnet for dispensers equipped with a standard “flapper” switch.
- Optional vapor insert increases the vapor back pressure, closely matching that of the competition, and making installation a breeze, with little-to-no changes to the vacuum pump draw.
- Optional sightglass provides a clear window for the customer to view the fuel as it passes through the main poppet valve.
- ADA-compliant EZ Lever reduces the force required to open the main poppet valve by 50%, resulting in a lever operating force ≤5 lbs.



MODEL NO.
6536041

New Unleaded PHG Nozzles

MODEL NO.	DESCRIPTION	SHIPPING WEIGHT LBS (KG)
6536041	with Two Notch Hold Open Clip and Vapor Escape Guard	3.3 (1.5)
		[^] NOT LISTED

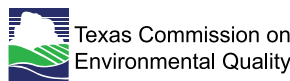

 WARNING: Cancer and Reproductive Harm - www.P65Warnings.ca.gov

V34 ORVR Nozzles

Pressure-activated, automatic shut-off vacuum assist nozzle for full-service and self-service stations.

Dimensions

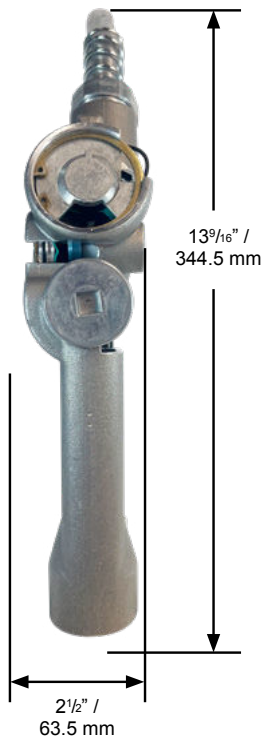
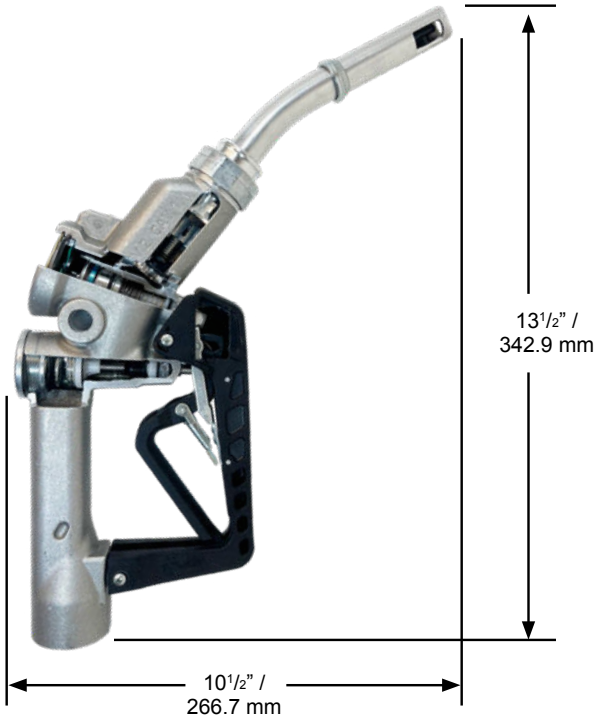

Construction

Body	One piece sand cast aluminum with high-impact polymer handguard
Seals	Fluorocarbon
Packing	Double o-ring seal protected by fiber-reinforced Teflon®
Lever	Two-piece polymer EZ Lever
Inlet	1-1/4" - 18 Unified (31.75 mm)

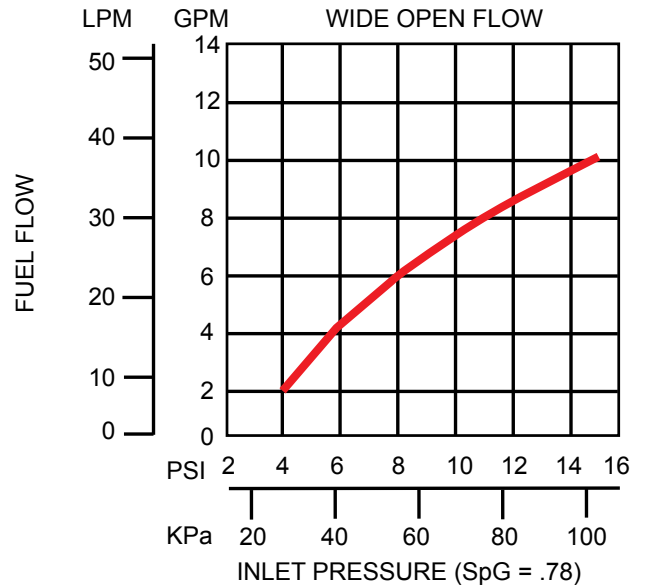
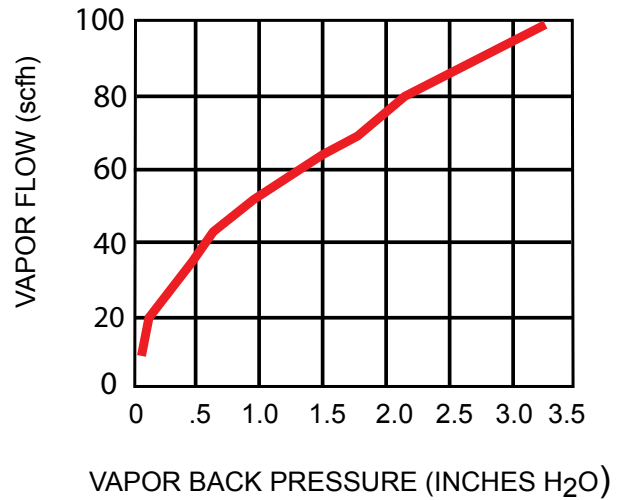

V34 ORVR **Nozzles**

Pressure-activated, automatic shut-off vacuum assist nozzle for full-service and self-service stations.

Nozzle Options

Nozzle Guard Options



Waffle Guard Options



1808 Waffle Guard

Handguard Options



Standard Polymer Handguard

Gilbarco Polymer Handguard
(with or without Magnet)

Tokheim Polymer Handguard
(with or without Magnet)

Wayne Polymer Handguard
(with or without Magnet)

Latch Plate Options

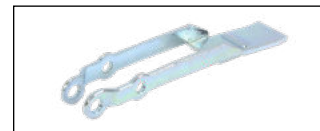

1 - Position Latch Plate

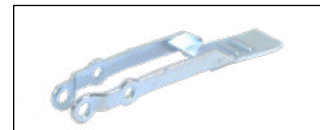

2 - Position Latch Plate

Lever Options



Lever without Hold Open Clip



Lever with Hold Open Clip

TUV Vapor Insert



07329

Sightglass Option



V34 ORVR Nozzles

Pressure-activated, automatic shut-off vacuum assist nozzle for full-service and self-service stations.

System Options

Safe-T-Breaks®

MODEL NO.	DESCRIPTION
006560	Reconnectable Safe-T-Break® for 1-1/4" THREADS
014592	MAGBREAK® Coax 1.25
015377	Non-reconnectable Safe-T-Break® 1-1/4"

Spouts

MODEL NO.	DESCRIPTION
006291	V34 Spout Assy Kit (Includes 004000 VSG and 006391 Spout Assembly)
006391	V34 Spout Assembly with Streamshaper®

Pressure/Vacuum Vents

MODEL NO.	DESCRIPTION
004620	2" Slip-On Pressure Vacuum Vent
004885	2" Thread-On Pressure Vacuum Vent - NPT
005885	2" Thread-On Pressure Vacuum Vent with Internal Screen - NPT

Accessories, Testing and Maintenance

MODEL NO.	DESCRIPTION
000397	Unleaded Spout Gauge
003593	Hold Open Clip Kit
004000	Vapor Splash Guard (VSG) with Clamp
004039	Vapor Splash Guard Clamp
004335	O-ring, Air / Liquid Test Spout Adaptor
004360	Air / Liquid Spout Adaptor
005233	O-ring Kit
005260	Tool for dry Air / Liquid Test
005837	Vapor Assist Flo-Equalizer®
006497	VSG Clamp Tool
006941	Hose Conversion Adaptor M34 x 1.5
007089	Nozzle Service Kit
010073	Waffle VSG with Clamp (single notch V34)
010076	Waffle VSG without Clamp (single notch V34)

















Swivels

MODEL NO.	DESCRIPTION
014620	Multi-Plane Swivel, 1-1/4"

Guards

MODEL NO.	DESCRIPTION
004231	Full Grip Reguard
005494	Lever Guard
006628	POPD® S Clear Cover
006660	POPD® S Full Grip Guard
006951	Full Grip Guard
007220	POPD® S Full Grip Reguard
007999	POPD® H Clear Cover
008184	POPD® H Full Grip Guard
008191	POPD® H Full Grip Reguard
010089	Black Handle Cover
014526	Mate Guard

Guard Color Chart

COLOR	SUFFIX	COLOR	SUFFIX	COLOR <i>CUSTOM</i>	SUFFIX
 Blue	-01	 Gold	-08	 Amoco Blue	-07 <i>CUSTOM</i>
 Red	-02	 Silver	-09	 Apple Green	-18 <i>CUSTOM</i>
 Green	-03	 BP Green	-16	 Purple	-19 <i>CUSTOM</i>
 Black	-04	 M Blue	-21	 Pink	-20 <i>CUSTOM</i>
 Yellow	-05	 Orange	-39	 BPS Green	-22 <i>CUSTOM</i>
 White	-06				

Scuff Guards are to be ordered with the corresponding guard color option added to the model number. Example: If BLUE guards are desired, add guard color option -01 to the model number (159504-01). For custom colors, a minimum order of 4,000 guards will be required.

V34iS Nozzles

Pressure-activated, automatic shut-off vacuum assist nozzle for full-service and self-service stations.

- V34iS nozzle shuts off when:
 - the pump shuts off.
 - the gas tank is full.
 - the lever is opened before the pump is turned on.
 - the leak detector has not completed the test cycle.
- Stainless steel reinforced spout bushing keeps spout tip round, and acts as a captive fastener to prevent tip-end sensor damage.
- Nozzle is equipped with a unique Flo-Stop® device that shuts off the nozzle if it falls from the fill neck or raises above the horizontal.
- StreamShaper® reduces turbulence for straighter fuel flow and less splash back spillage.
- Tilt poppet design provides precise “to-the-penny” dispensing.
- Strong vapor valve in the nozzle that is mechanically operated by the on-off action of the nozzle’s lever.
- Husky® vapor return line is an internal part of the body casting, thus eliminating potential vapor leak points and fugitive evaporative emissions from the fuel remaining in the vapor path of the hose.
- Vapor assist achieved at the body end of the spout where a vapor ring catches emissions.
- Uses international spout and aluminum vapor collector.

- Nozzle comes standard with a full grip guard.
- Optional cold weather seals are rated to -40 °F/C.
- Optional Gilbarco, Tokheim, and Wayne handguards can be fitted with a magnet to trigger the dispenser’s proximity switch, or can be provided without the magnet for dispensers equipped with a standard “flapper” switch.
- Optional vapor insert increases the vapor back pressure, closely matching that of the competition, and making installation a breeze, with little-to-no changes to the vacuum pump draw.
- Optional sightglass provides a clear window for the customer to view the fuel as it passes through the main poppet valve.
- ADA-compliant EZ Lever reduces the force required to open the main poppet valve by 50%, resulting in a lever operating force ≤5 lbs.

New Unleaded PHG Nozzles

MODEL NO.	DESCRIPTION	SHIPPING WEIGHT LBS (KG)
E13177041N^	with Two Notch Hold Open Clip, Mate Guard and Gilbarco Magnetic Handguard	3.3 (1.5)
E13800106N^	with Two Notch Hold Open Clip, Mate Guard and Tokheim Magnetic Handguard	3.3 (1.5)
E13986223N^	with Two Notch Hold Open Clip, Mate Guard and Wayne Magnetic Handguard	3.3 (1.5)
E16588041N^	with Two Notch Hold Open Clip, Mate Guard and Wayne Magnetic Handguard	3.3 (1.5)

^ NOT LISTED



MODEL NO.
E15071041A*



II 1 G
EN 13012
Type 1



P-TU7-8113626964



WARNING: Cancer and Reproductive Harm - www.P65Warnings.ca.gov

V34iS Nozzles

Pressure-activated, automatic shut-off vacuum assist nozzle for full-service and self-service stations.

Dimensions

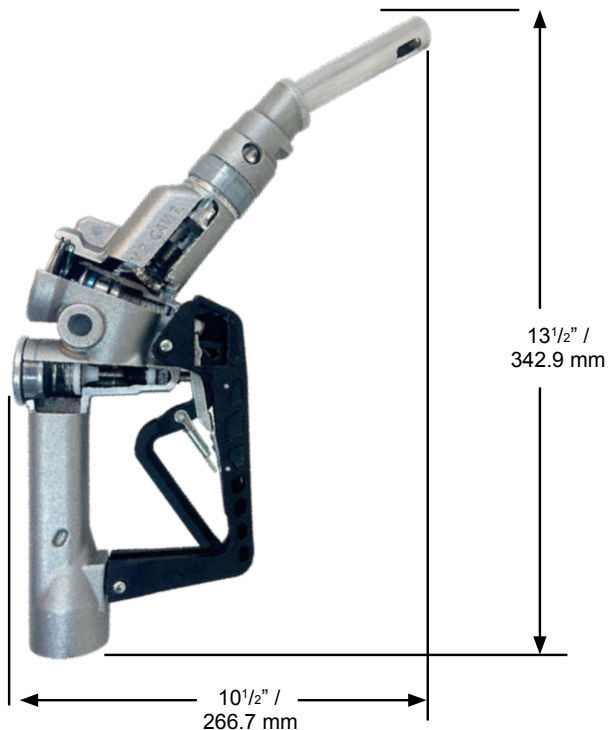

Construction

Body	One piece sand cast aluminum with high-impact polymer handguard
Seals	Fluorocarbon
Packing	Double o-ring seal protected by fiber-reinforced Teflon®
Lever	Two-piece polymer EZ Lever
Inlet	M34 x 1.5mm

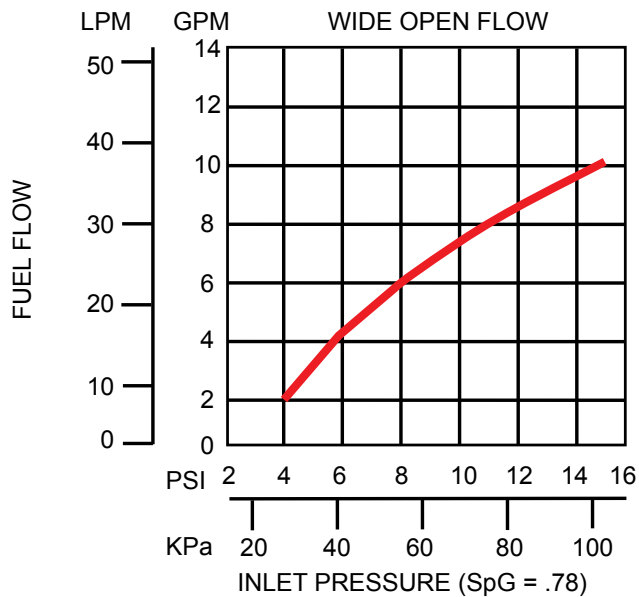
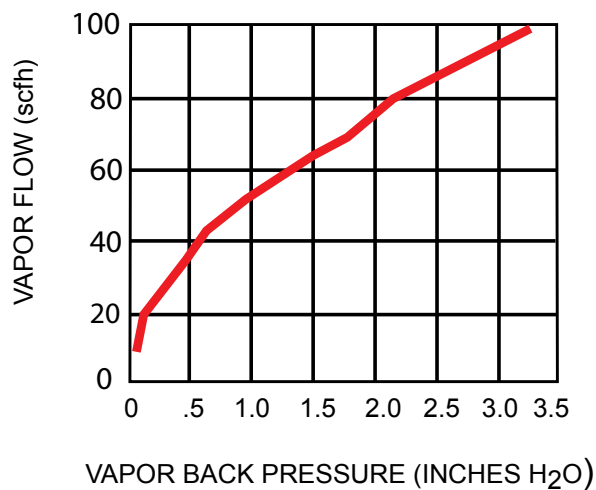

V34iS Nozzles

Pressure-activated, automatic shut-off vacuum assist nozzle for full-service and self-service stations.

Nozzle Options

Nozzle Guard Options



Waffle Guard Options



1808 Waffle Guard

Handguard Options



Standard Polymer Handguard

Gilbarco Polymer Handguard
(with or without Magnet)

Tokheim Polymer Handguard
(with or without Magnet)

Wayne Polymer Handguard
(with or without Magnet)

Latch Plate Options



1 - Position Latch Plate



2 - Position Latch Plate

Lever Options



Lever without Hold Open Clip



Lever with Hold Open Clip

TUV Vapor Insert



07329

Sightglass Option



V34iS Nozzles

Pressure-activated, automatic shut-off vacuum assist nozzle for full-service and self-service stations.

System Options

Safe-T-Breaks®

MODEL NO.	DESCRIPTION
004034	Reconnectable Safe-T-Break®
004034A*	Reconnectable Safe-T-Break® - Atex
005134A*	Non-Reconnectable Safe-T-Break® - Atex
006210	Non-Reconnectable Safe-T-Break®
008332	MAGBREAK® Coax M34 CK
010513	Non-Reconnectable Safe-T-Break® - Shearpin

Spouts

MODEL NO.	DESCRIPTION
006291	V34 Spout Assy Kit (Includes 004000 VSG and 006391 Spout Assembly)
006391	V34 Spout Assembly with Streamshaper®

Pressure/Vacuum Vents

MODEL NO.	DESCRIPTION
004620	2" Slip-On Pressure Vacuum Vent
004885	2" Thread-On Pressure Vacuum Vent - NPT
005885	2" Thread-On Pressure Vacuum Vent with Internal Screen - NPT

Accessories, Testing and Maintenance

MODEL NO.	DESCRIPTION
000397	Unleaded Spout Gauge
003593	Hold Open Clip Kit
004335	O-ring, Air / Liquid Test Spout Adaptor
004360	Air / Liquid Spout Adaptor
005233	O-ring Kit
005260	Tool for dry Air / Liquid Test
005837	Vapor Assist Flo-Equalizer®
006941	Hose Conversion Adaptor M34 x 1.5
007089	Nozzle Service Kit

















Swivels

MODEL NO.	DESCRIPTION
004605	Multi-Plane Swivel
004605A*	Multi-Plane Swivel - Atex

Guards

MODEL NO.	DESCRIPTION
004231	Full Grip Reguard
005494	Lever Guard
006628	POPD® S Clear Cover
006660	POPD® S Full Grip Guard
006951	Full Grip Guard
007220	POPD® S Full Grip Reguard
007999	POPD® H Clear Cover
008184	POPD® H Full Grip Guard
008191	POPD® H Full Grip Reguard
010089	Black Handle Cover
014526	Mate Guard

Guard Color Chart

COLOR	SUFFIX	COLOR	SUFFIX	COLOR <i>CUSTOM</i>	SUFFIX
 Blue	-01	 Gold	-08	 Amoco Blue	-07 <i>CUSTOM</i>
 Red	-02	 Silver	-09	 Apple Green	-18 <i>CUSTOM</i>
 Green	-03	 BP Green	-16	 Purple	-19 <i>CUSTOM</i>
 Black	-04	 M Blue	-25	 Pink	-20 <i>CUSTOM</i>
 Yellow	-05	 Orange	-21	 BPS Green	-22 <i>CUSTOM</i>
 White	-06				

Scuff Guards are to be ordered with the corresponding guard color option added to the model number. Example: If BLUE guards are desired, add guard color option -01 to the model number (159504-01). For custom colors, a minimum order of 4,000 guards will be required.



Distilled Spirits Dispensing

SST WN **Nozzles**

Automatic shut-off nozzle for wine and distilled spirits dispensing.

- SST WN nozzle shuts off when the container is full.
- Stainless steel construction.
- Modular design for easy cleaning.
- Constructed with food grade materials.
- Seals provide maximum durability and chemical resistance to high concentrations of ethanols.
- Comes standard with mate guard and black polymer handle cover.



MODEL NO.
E8528104N^

New Nozzles with BSP Inlet

MODEL NO.	DESCRIPTION	SHIPPING WEIGHT LBS (KG)
E8528104N^	with Two Notch Hold Open Clip, Mate Guard and Polymer Handle Cover	4.6 (2.1)
		^ NOT LISTED

New Nozzles without Inlet Threads

MODEL NO.	DESCRIPTION	SHIPPINGST
4.7 (2.1)		
		^ NOT LISTED



 WARNING: Cancer and Reproductive Harm - www.P65Warnings.ca.gov

SST WN Nozzles

Automatic shut-off nozzle for wine and distilled spirits dispensing.

Dimensions

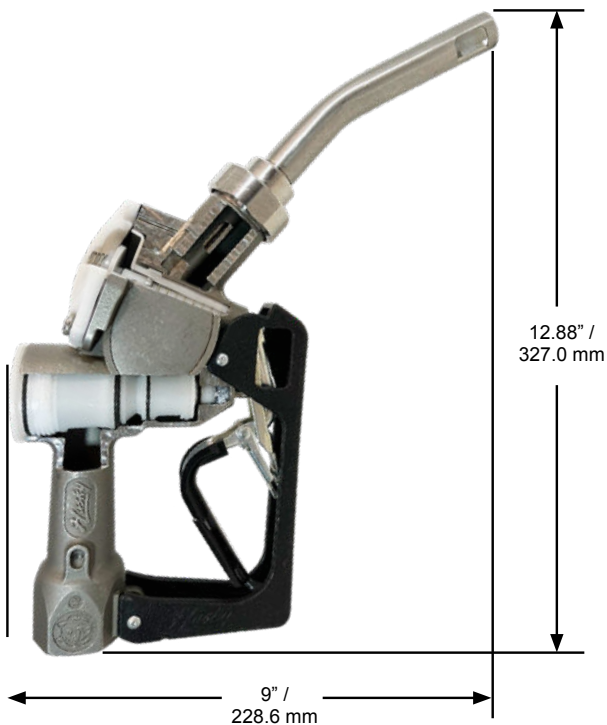

Construction

Body	Investment cast stainless steel with high-impact polymer handguard
Seals	Ethylene Propylene
Packing	Double o-ring seal protected by fiber reinforced Teflon®
Lever	One piece contoured steel with hard plastic cover
Inlet	1" / 25.4 mm BSPP or M34 x 1.5 mm

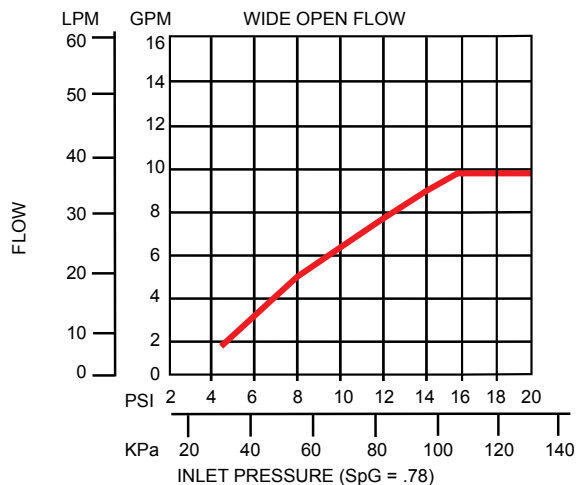

SST WN **Nozzles**

Automatic shut-off nozzle for wine and distilled spirits dispensing.

Nozzle Options

Nozzle Guard Options



Full Grip Guard

Mate Guard

Lever Options

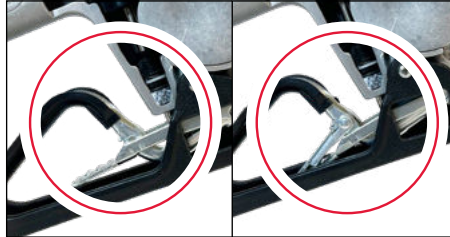

Lever without Hold
Open Clip

Lever with Hold
Open Clip

Latch Plate Options

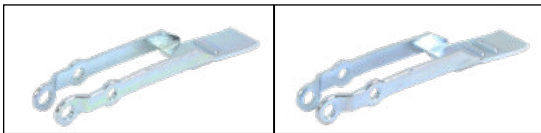

1 - Position Latch Plate

2 - Position Latch Plate

SST WN Nozzles

Automatic shut-off nozzle for wine and distilled spirits dispensing.

System Options

Swivels

MODEL NO.	DESCRIPTION
007269	1" M x 1" M BSPP Inline Swivel
007467	1" F x 1" M BSPP Inline Swivel

Spouts

MODEL NO.	DESCRIPTION
007362	with Flo-Stop®

















Guards

MODEL NO.	DESCRIPTION
000226	Mate Nozzle Guard
000554	Full Grip Guard
005494	Lever Guard
007295	Mate Handle Guard

Accessories, Testing and Maintenance

MODEL NO.	DESCRIPTION
007523	1" BSPP Seal Kit Assembly

Guard Color Chart

COLOR	SUFFIX	COLOR	SUFFIX	COLOR <i>CUSTOM</i>	SUFFIX
 Blue	-01	 Gold	-08	 Amoco Blue	-07 <i>CUSTOM</i>
 Red	-02	 Silver	-09	 Apple Green	-18 <i>CUSTOM</i>
 Green	-03	 BP Green	-16	 Purple	-19 <i>CUSTOM</i>
 Black	-04	 M Blue	-21	 Pink	-20 <i>CUSTOM</i>
 Yellow	-05	 Orange	-39	 BPS Green	-22 <i>CUSTOM</i>
 White	-06				

Scuff Guards are to be ordered with the corresponding guard color option added to the model number.
 Example: If BLUE guards are desired, add guard color option -01 to the model number (159504-01).
 For custom colors, a minimum order of 4,000 guards will be required.

X WN Nozzles

Automatic shut-off nozzle for distilled spirits dispensing.

- X WN nozzle shuts off when the container is full.
- Stainless steel reinforced spout bushing keeps spout tip round, and acts as a captive fastener to prevent tip-end sensor damage.
- *StreamShaper*[®] reduces turbulence for straighter fuel flow and less splash back spillage.
- Aluminum body, spout, and internal parts are nickel plated to prevent contamination and corrosion.
- Seals provide maximum durability and chemical resistance to higher concentrations of ethanol.
- Comes standard with a mate guard and black plastic handle cover.
- ADA-compliant EZ Lever reduces the force required to open the main poppet valve by 50%, resulting in a lever operating force ≤5 lbs.



MODEL NO.
E840004N[^]

New Nozzles with NPT Inlet

MODEL NO.	DESCRIPTION	SHIPPING WEIGHT LBS (KG)
E840004N [^]	with Two Notch Hold Open Clip, Mate Guard and Polymer Handle Cover	2.8 (1.2)
		[^] NOT LISTED

New Nozzles wit BSP Threads

MODEL NO.	DESCRIPTION	SHIPPING WEIGHT LBS (KG)
E840016N [^]	with Two Notch Hold Open Clip, Mate Guard and Polymer Handle Cover	2.8 (1.2)
		[^] NOT LISTED



 WARNING: Cancer and Reproductive Harm - www.P65Warnings.ca.gov

X WN Nozzles

Automatic shut-off nozzle for distilled spirits dispensing.

Dimensions

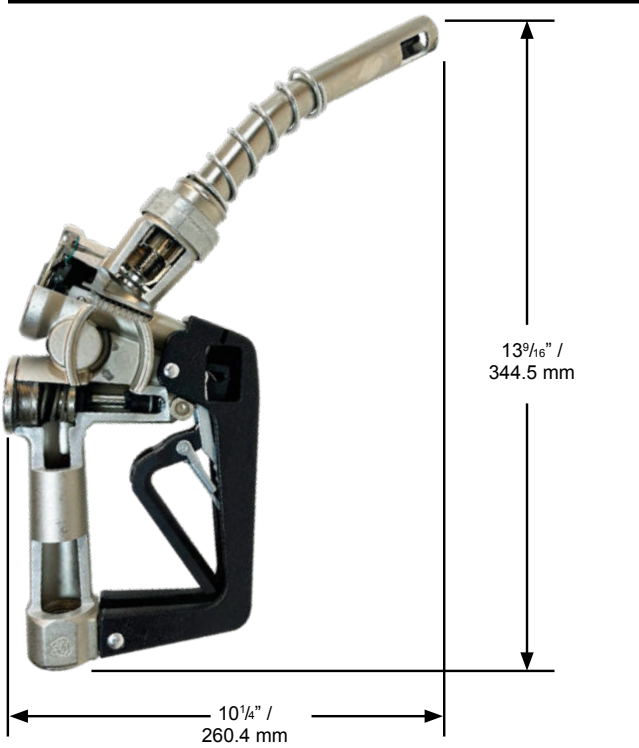

Construction

Body	Nickel-plated die cast aluminum with high-impact polymer handguard
Seals	Fluorocarbon
Packing	Double o-ring seal protected by fiber-reinforced Teflon®
Lever	Two piece polymer EZ Lever
Inlet	3/4" (19 mm) NPT or 3/4" (19 mm) BSP

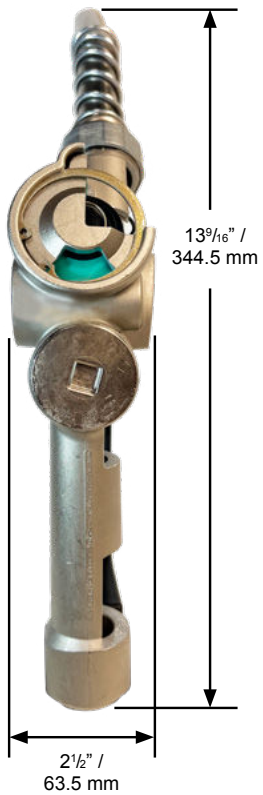
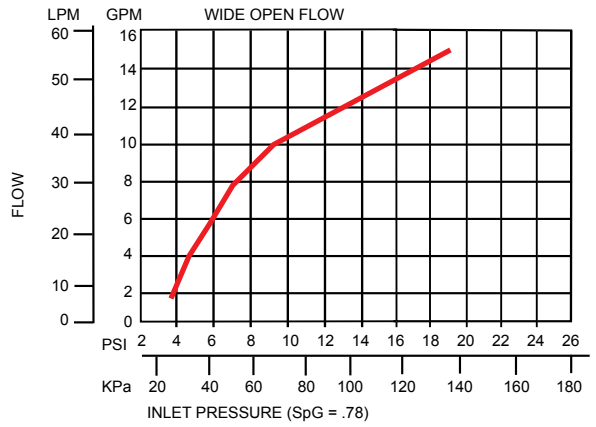

X WN Nozzles

Automatic shut-off nozzle for distilled spirits dispensing.

Nozzle Options

Nozzle Guard Options



Full Grip Guard

Mate Guard

Lever Options

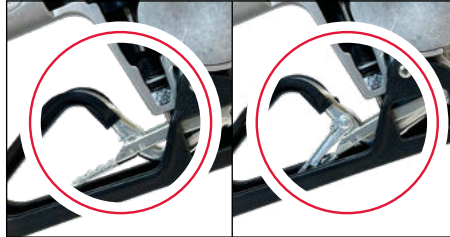

Lever without Hold
Open Clip

Lever with Hold
Open Clip

Latch Plate Options

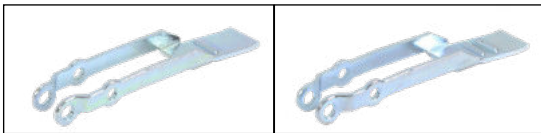

1 - Position Latch Plate

2 - Position Latch Plate

X WN Nozzles

Automatic shut-off nozzle for distilled spirits dispensing.

System Options

Swivels

MODEL NO.	DESCRIPTION
006350^	3/4" M x 3/4" F NPT Multi-Plane E85 Swivel

















Spouts

MODEL NO.	DESCRIPTION
006207	Unleaded E85 Spout Assembly

Guards

MODEL NO.	DESCRIPTION
003440	Mate Easy-On Package
003795	Mate Guard
004145	Full Grip Guard
007361	Black Handle Cover

Guard Color Chart

COLOR	SUFFIX	COLOR	SUFFIX	COLOR <i>CUSTOM</i>	SUFFIX
 Blue	-01	 Gold	-08	 Amoco Blue	-07 <i>CUSTOM</i>
 Red	-02	 Silver	-09	 Apple Green	-18 <i>CUSTOM</i>
 Green	-03	 BP Green	-16	 Purple	-19 <i>CUSTOM</i>
 Black	-04	 M Blue	-21	 Pink	-20 <i>CUSTOM</i>
 Yellow	-05	 Orange	-39	 BPS Green	-22 <i>CUSTOM</i>
 White	-06				

Scuff Guards are to be ordered with the corresponding guard color option added to the model number. Example: If BLUE guards are desired, add guard color option -01 to the model number (159504-01). For custom colors, a minimum order of 4,000 guards will be required.

1A WN Nozzles

Automatic shut-off nozzle for distilled spirits dispensing.

- 1A WN nozzle shuts off when the container is full.
- Stainless steel reinforced spout bushing keeps spout tip round, and acts as a captive fastener to prevent tip-end sensor damage.
- *StreamShaper*[®] reduces reduces turbulence for straighter flow and less splash back spillage.
- Aluminum body, spout, and internal parts are nickel plated to prevent contamination and corrosion.
- Seals provide maximum durability and chemical resistance to higher concentrations of ethanol.
- Comes standard with a mate guard and black plastic handle cover.
- ADA-compliant EZ Lever reduces the force required to open the main poppet valve by 50%, resulting in a lever operating force ≤5 lbs.



MODEL NO.
E874203N[^]

New Nozzles with NPT Inlet

MODEL NO.	DESCRIPTION	SHIPPING WEIGHT LBS (KG)
E874203N [^]	with Two Notch Hold Open Clip, Mate Guard and Polymer Handle Cover	3.3 (1.4)

[^] NOT LISTED

New Nozzles with BSP Threads

MODEL NO.	DESCRIPTION	SHIPPING WEIGHT LBS (KG)
E874215N [^]	with Two Notch Hold Open Clip, Mate Guard and Polymer Handle Cover	3.3 (1.4)

[^] NOT LISTED



 WARNING: Cancer and Reproductive Harm - www.P65Warnings.ca.gov

1A WN Nozzles

Automatic shut-off nozzle for distilled spirits dispensing.

Dimensions

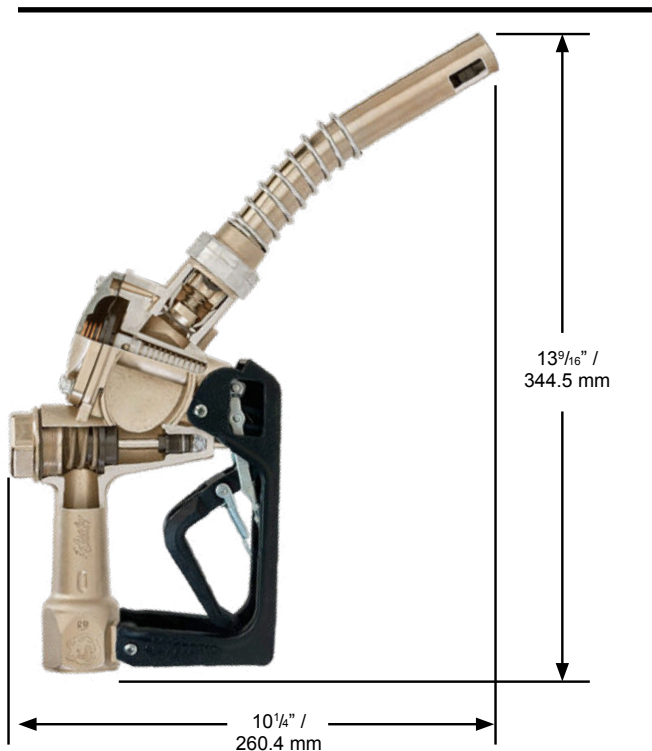

Construction

Body	Nickel-plated die cast aluminum with high-impact polymer handguard
Seals	Fluorocarbon
Packing	Double o-ring seal protected by fiber-reinforced Teflon®
Lever	Two piece polymer EZ Lever
Inlet	1" (25.4 mm) NPT or 1" (25.4 mm) BSP

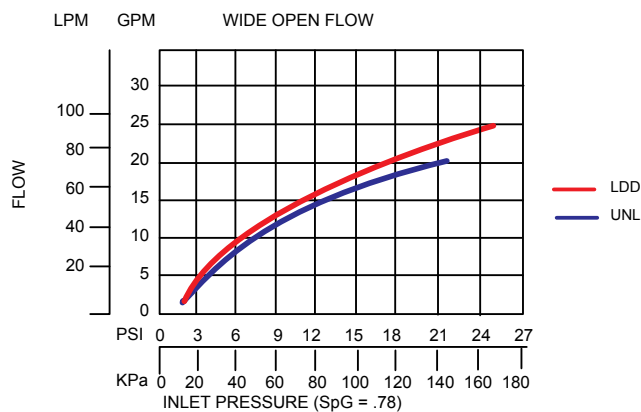

1A WN Nozzles

Automatic shut-off nozzle for distilled spirits dispensing.

Nozzle Options

Nozzle Guard Options



Full Grip Guard

Mate Guard

Lever Options

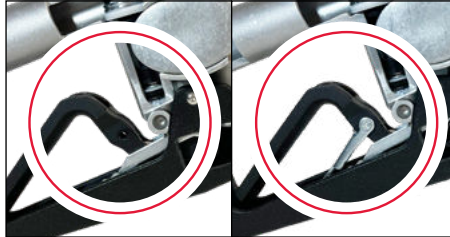

Lever without Hold
Open Clip

Lever with Hold
Open Clip

Latch Plate Options

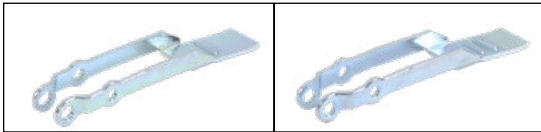

1 - Position Latch Plate

2 - Position Latch Plate

1A WN Nozzles

















Automatic shut-off nozzle for distilled spirits dispensing.

System Options

Guards

MODEL NO.	DESCRIPTION
000226	Mate Nozzle Guard
000554	Full Grip Guard
005494	Lever Guard
007295	Mate Handle Guard

Guard Color Chart

COLOR	SUFFIX	COLOR	SUFFIX	COLOR <i>CUSTOM</i>	SUFFIX
 Blue	-01	 Gold	-08	 Amoco Blue	-07 <i>CUSTOM</i>
 Red	-02	 Silver	-09	 Apple Green	-18 <i>CUSTOM</i>
 Green	-03	 BP Green	-16	 Purple	-19 <i>CUSTOM</i>
 Black	-04	 M Blue	-21	 Pink	-20 <i>CUSTOM</i>
 Yellow	-05	 Orange	-39	 BPS Green	-22 <i>CUSTOM</i>
 White	-06				

Scuff Guards are to be ordered with the corresponding guard color option added to the model number.
Example: If BLUE guards are desired, add guard color option -01 to the model number (159504-01).
 For custom colors, a minimum order of 4,000 guards will be required.

VIII WN Nozzles

High-Flow automatic shut-off nozzle for distilled spirits dispensing.

- VIII WN nozzle shuts off when the container is full.
- Dual poppet design equalizes pressure on both sides of the main poppet valve in order to aid in lifting the lever, and opening the main poppet valve for full flow.
- *StreamShaper*[®] reduces turbulence for straighter fuel flow and less splash back spillage.
- Aluminum body, spout, and internal parts are nickel plated to prevent contamination and corrosion.
- Seals provide maximum durability and chemical resistance to higher concentrations of ethanol.
- Strong flow (up to 75 gpm / 283.9 Lpm).
- Comes standard with a full grip guard.



MODEL NO.
874110N[^]

New Nozzle with NPT Inlet

MODEL NO.	DESCRIPTION	SHIPPING WEIGHT LBS (KG)
874110N [^]	with Three Notch Hold Open Clip, without Spout Bushing	3.9 (1.7)
		[^] NOT LISTED

New Nozzle with BSP Inlet

MODEL NO.	DESCRIPTION	SHIPPING WEIGHT LBS (KG)
874138N [^]	with Three Notch Hold Open Clip, without Spout Bushing	3.9 (1.7)
		[^] NOT LISTED



WARNING: Cancer and Reproductive Harm - www.P65Warnings.ca.gov

VIII WN Nozzles

High-Flow automatic shut-off nozzle for distilled spirits dispensing.

Dimensions

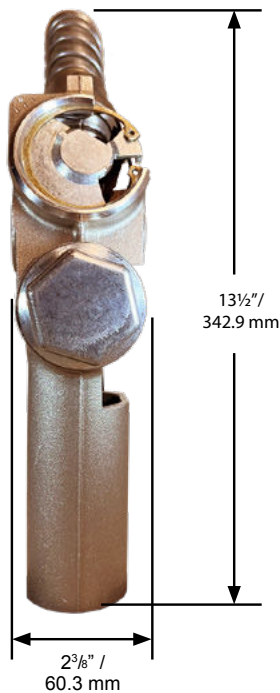
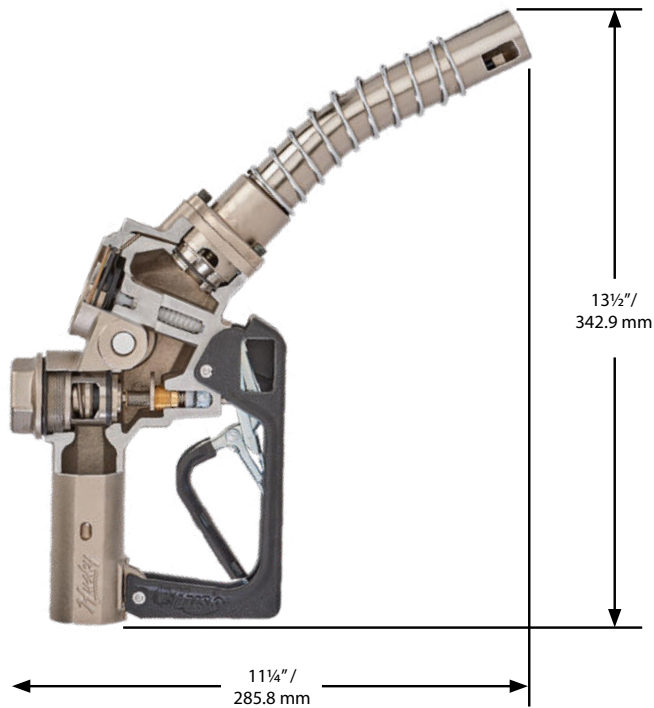

Construction

Body	Nickel-plated sand cast aluminum with high-impact polymer handguard
Seals	Fluorocarbon
Packing	Double o-ring seal protected by fiber-reinforced Teflon®
Lever	One piece contoured steel with hard polymer lever cover
Inlet	1" (25.4 mm) NPT or 1" (25.4 mm) BSP

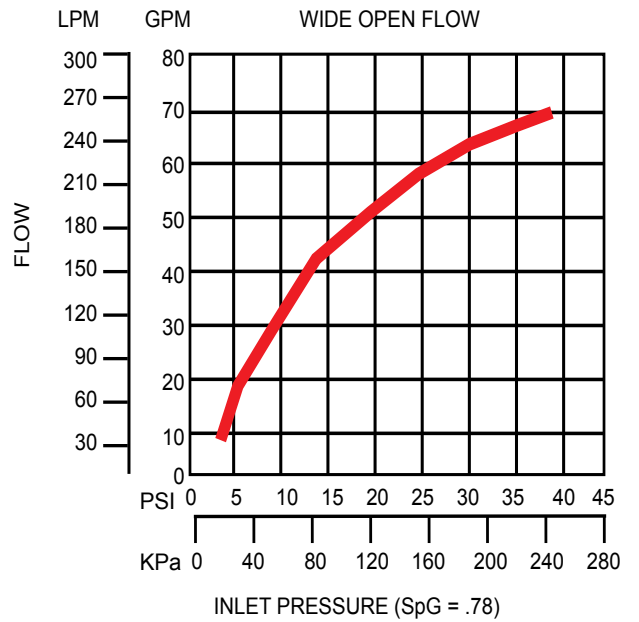

VIII WN **Nozzles**

High-Flow automatic shut-off nozzle for distilled spirits dispensing.

Nozzle Options

Nozzle Guard Options



Full Grip Guard

Lever Options

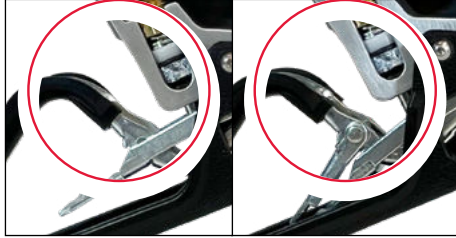

Lever without Hold
Open Clip

Lever with Hold
Open Clip

Latch Plate Options

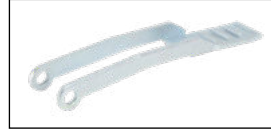

3 - Position Latch Plate

VIII WN **Nozzles**

















High-Flow automatic shut-off nozzle for distilled spirits dispensing.

System Options

Guards

MODEL NO.	DESCRIPTION
000554	Full Grip Guard
005494	Lever Guard

Guard Color Chart

COLOR	SUFFIX	COLOR	SUFFIX	COLOR <i>CUSTOM</i>	SUFFIX
 Blue	-01	 Gold	-08	 Amoco Blue	-07 <i>CUSTOM</i>
 Red	-02	 Silver	-09	 Apple Green	-18 <i>CUSTOM</i>
 Green	-03	 BP Green	-16	 Purple	-19 <i>CUSTOM</i>
 Black	-04	 M Blue	-25	 Pink	-20 <i>CUSTOM</i>
 Yellow	-05	 Orange	-39	 BPS Green	-22 <i>CUSTOM</i>
 White	-06				

Scuff Guards are to be ordered with the corresponding guard color option added to the model number.
 Example: If BLUE guards are desired, add guard color option -01 to the model number (159504-01).
 For custom colors, a minimum order of 4,000 guards will be required.

1690 WN Nozzles

Extreme High-Flow automatic shut-off nozzle for distilled spirits dispensing.

- 1690 WN nozzle shuts off when the container is full.
- Nozzle is equipped with two-position hold open latch.
- Dual poppet design equalizes pressure on both sides of the main poppet valve in order to aid in lifting the lever, and opening the main poppet valve for full flow.
- Design includes a self-adjusting stem packing.
- Right angle design allows nozzle to “fit” close to walls and corners.
- Aluminum body, spout, and internal parts are nickel plated to prevent contamination and corrosion.
- Seals provide maximum durability and chemical resistance to higher concentrations of ethanol.
- Strong flow (up to 100 gpm / 378.5 Lpm).
- Comes standard with a full grip guard.

New Nozzles with NPT Inlet

MODEL NO.	DESCRIPTION	SHIPPING WEIGHT LBS (KG)
875010N [^]	with Two Position Hold Open Device	3.9 (1.7)
		[^] NOT LISTED

New Nozzles wit BSP Threads

MODEL NO.	DESCRIPTION	SHIPPING WEIGHT LBS (KG)
875038N [^]	with Two Position Hold Open Device	3.9 (1.7)
		[^] NOT LISTED



MODEL NO.
875010N[^]



 WARNING: Cancer and Reproductive Harm - www.P65Warnings.ca.gov

1690 WN Nozzles

Extreme High-Flow automatic shut-off nozzle for distilled spirits dispensing.

Dimensions

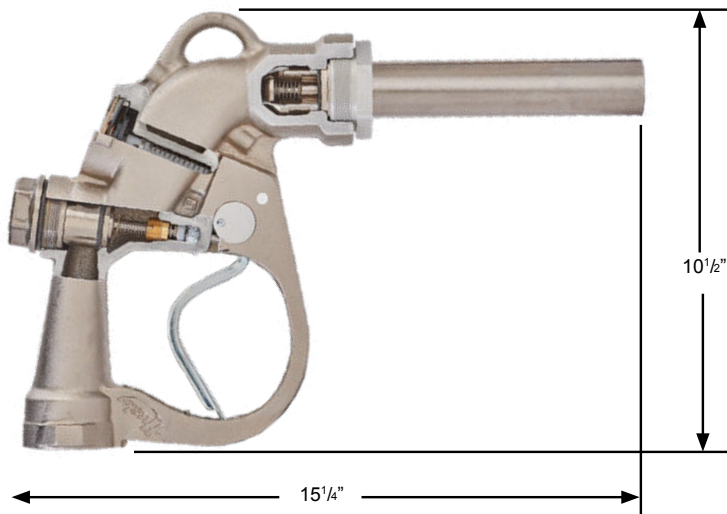

Construction

Body	Nickel-plated sand cast aluminum
Seals	Fluorocarbon
Packing	Double o-ring seal protected by fiber-reinforced Teflon®
Lever	One piece contoured steel
Inlet	1-1/2" (38.1 mm) NPT or 1-1/2" (38.1 mm) BSP

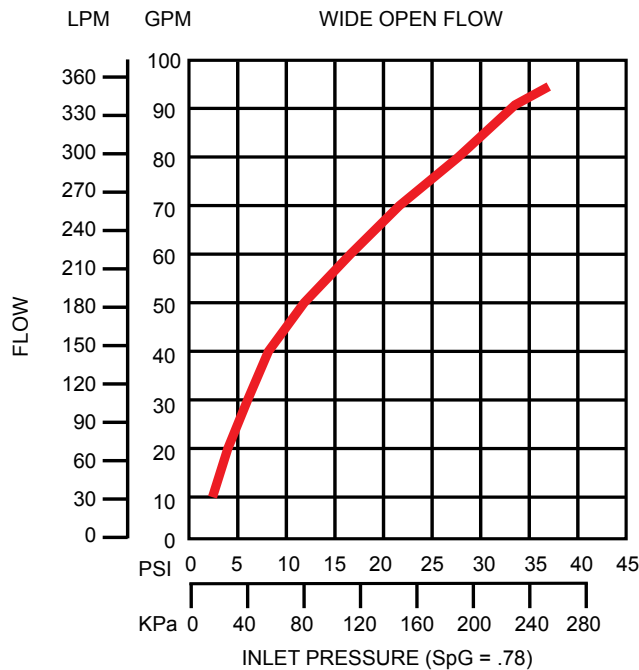

1690 WN **Nozzles**

Extreme High-Flow automatic shut-off nozzle for distilled spirits dispensing.

Nozzle Options

Hold Open Latch Pin Options

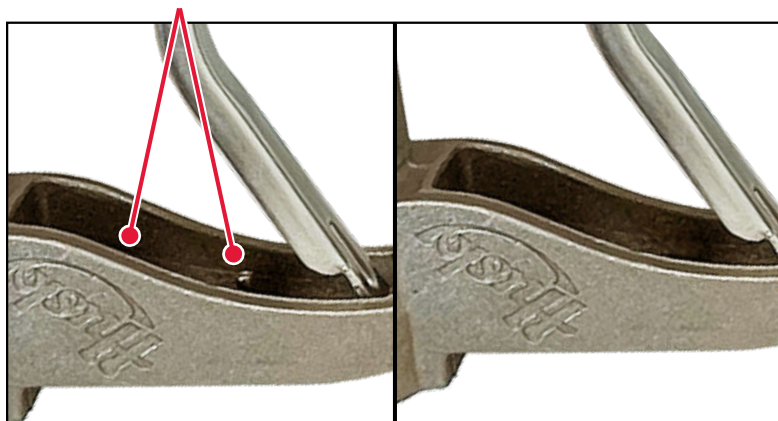

With Hold Open Latch Pins

Without Hold Open Latch Pins



GENERAL FUELING PRODUCTS

Swivels

Standard Swivels

For standard fueling applications.

Features

All Husky® Multi-Plane Swivels

- Compatible with unleaded, diesel, and Ethanol blends through E10.
- Compact and light weight for easy handling.
- High flow rates due to laminar flow design.
- High strength step shoulder bearing diameters and impact absorbing stops.

Model 002950 Restricted Swivel

- Multi-Plane, 210° spherical rotation at the swivel nut.
- Double o-ring seals at each swivel provide long life at low temperatures (-40° F/C).

All Weather Swivels

- Multi-Plane, full 360° spherical rotation for easy movement of nozzle.
- Double o-ring seals at each swivel provide long life at low temperatures (-40° F/C).

Model No.	Size	Thread	Type	Shipping Wt Lbs/Kg
000350	3/4" M x 3/4" F	NPT	Multi-Plane Swivel	.50/.22
000352	1" M x 3/4" F	NPT	Multi-Plane Swivel	.66/.29
000355	3/4" M x 3/4" F	NPT	Multi-Plane Swivel, Black	.49/.22
000356	1" M x 3/4" F	NPT	Multi-Plane Swivel, Black	.66/.29
002272	3/4" M x 3/4" F	NPT	90° Swivel	.38/.17
001491	3/4" M x 3/4" F	BSPT	Multi-Plane Swivel	.50/.22
003590	3/4" M x 3/4" F	BSPP	Multi-Plane Swivel	.60/.27
003590A*	3/4" M x 3/4" F	BSPP	Multi-Plane Swivel - Atex	.60/.27
002771	3/4" M x 3/4" F	BSPP	90° Swivel	.38/.17
002771A*	3/4" M x 3/4" F	BSPP	90° Swivel - Atex	.38/.17

Construction

Body: High Aluminum Zinc Alloy

Inner O-ring: Fluorsilicone

Outer O-ring: Fluorocarbon

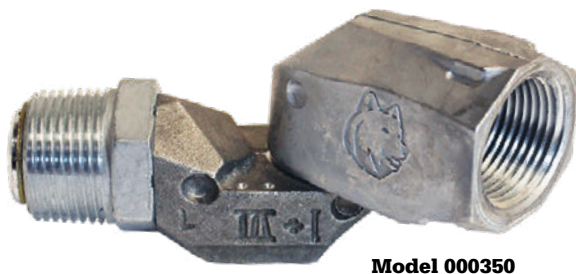

WARNING: Cancer and Reproductive Harm - www.P65Warnings.ca.gov

Standard Swivels

For standard fueling applications.

Dimensions

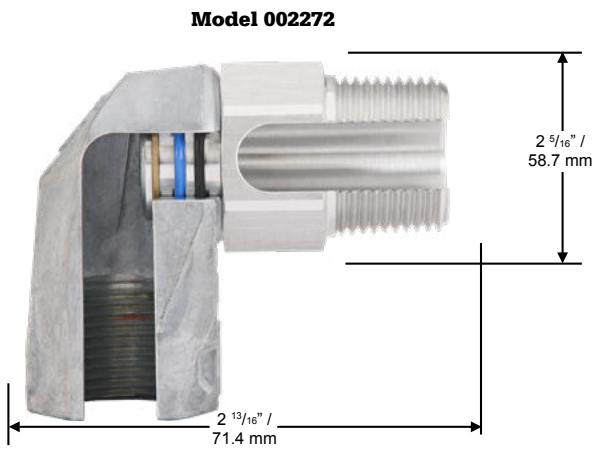
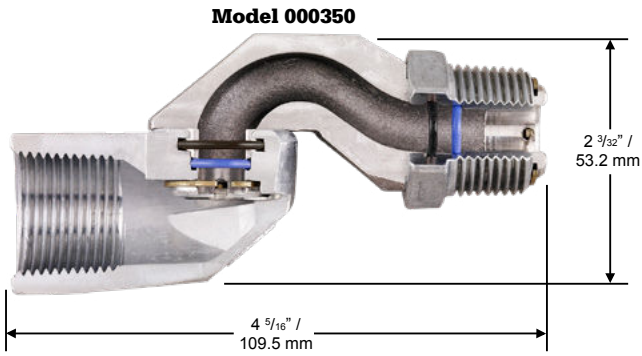

Flow Charts

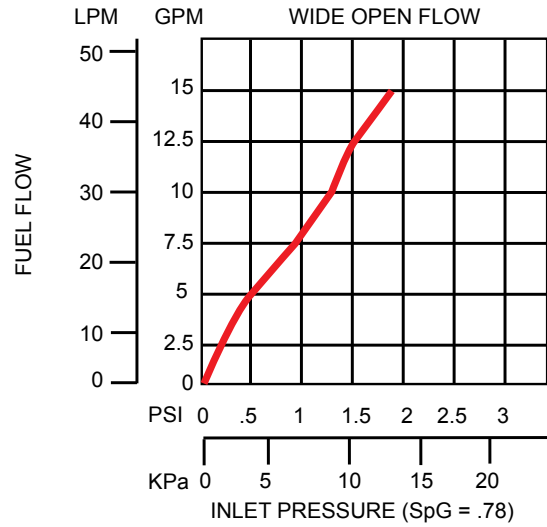

Inline Swivels

For standard fueling applications.

Features

All Husky® Multi-Plane Swivels

- Compatible with unleaded, diesel, and Ethanol blends through E10.
- Compact and light weight for easy handling.
- High flow rates due to laminar flow design.
- High strength step shoulder bearing diameters and impact absorbing stops.

All Weather Swivels

- Multi-Plane, full 360° spherical rotation for easy movement of nozzle.
- Double o-ring seals at each swivel provide long life at low temperatures (-40° F/C).

Model No.	Size	Thread	Type	Shipping Wt Lbs/Kg
003895	3/4" M x 3/4" F	NPT	Single Plane Swivel	1.4/.65
003898	3/4" M x 1" F	NPT	Single Plane Swivel	1.4/.65
008517	1" M x 1" F	NPT	Single Plane Swivel	1.4/.65
003753	3/4" M x 3/4" F	BSPT	Single Plane Swivel	1.4/.65
003760	3/4" M x 1" F	BSPT	Single Plane Swivel	1.4/.65
003830	1" M x 1" F	BSPP	Single Plane Swivel	1.4/.65

Construction

Body: Aluminum

Inner O-ring: Fluorsilicone

Outer O-ring: Fluorosilicone

Model 003895



WARNING: Cancer and Reproductive Harm - www.P65Warnings.ca.gov

Inline Swivels

For standard fueling applications.

Dimensions

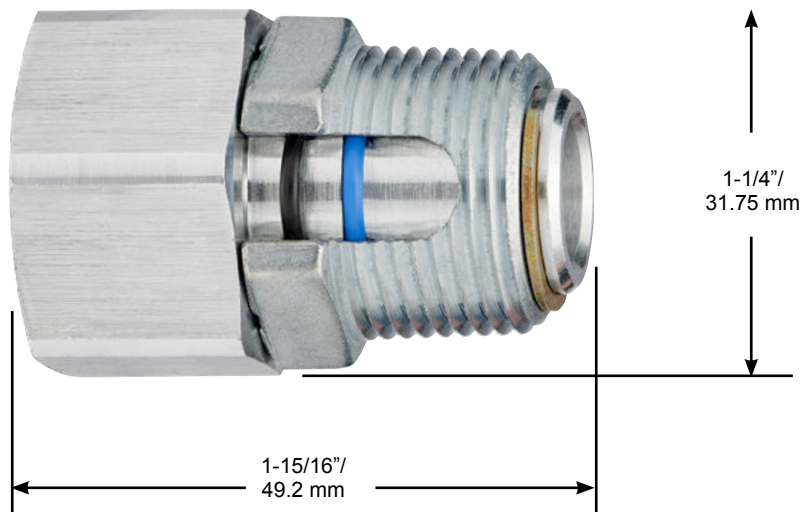

F&C Standard Swivels

For standard fueling applications.

Features

All Husky® Multi-Plane Swivels

- Compatible with unleaded, diesel, and Ethanol blends through E10.
- Compact and light weight for easy handling.
- High flow rates due to laminar flow design.
- High strength step shoulder bearing diameters and impact absorbing stops.

Model 002950 Restricted Swivel

- Multi-Plane, 210° spherical rotation at the swivel nut.
- Double o-ring seals at each swivel provide long life at low temperatures (-40° F/C).

All Weather Swivels

- Multi-Plane, full 360° spherical rotation for easy movement of nozzle.
- Double o-ring seals at each swivel provide long life at low temperatures (-40° F/C).

Model No.	Size	Thread	Type	Shipping Wt Lbs/Kg
000350	3/4" M x 3/4" F	NPT	Multi-Plane Swivel	.50/.22
000350R	3/4" M x 3/4" F	NPT	Multi-Plane Swivel for Retail	.50/.22
000352	1" M x 3/4" F	NPT	Multi-Plane Swivel	.66/.29
000355	3/4" M x 3/4" F	NPT	Multi-Plane Swivel, Black	.49/.22
000356	1" M x 3/4" F	NPT	Multi-Plane Swivel, Black	.66/.29
002272	3/4" M x 3/4" F	NPT	90° Swivel	.38/.17
001491	3/4" M x 3/4" F	BSPT	Multi-Plane Swivel	.50/.22
003590	3/4" M x 3/4" F	BSPP	Multi-Plane Swivel	.60/.27
003590A*	3/4" M x 3/4" F	BSPP	Multi-Plane Swivel - Atex	.60/.27
002771	3/4" M x 3/4" F	BSPP	90° Swivel	.38/.17
002771A*	3/4" M x 3/4" F	BSPP	90° Swivel - Atex	.38/.17

Construction

Body: High Aluminum Zinc Alloy

Inner O-ring: Fluorsilicone

Outer O-ring: Fluorocarbon

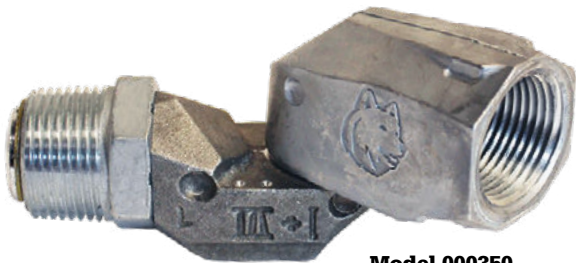

Model 000350



Model 002272



 WARNING: Cancer and Reproductive Harm - www.P65Warnings.ca.gov

F&C Standard Swivels

For standard fueling applications.

Dimensions

Model 000350

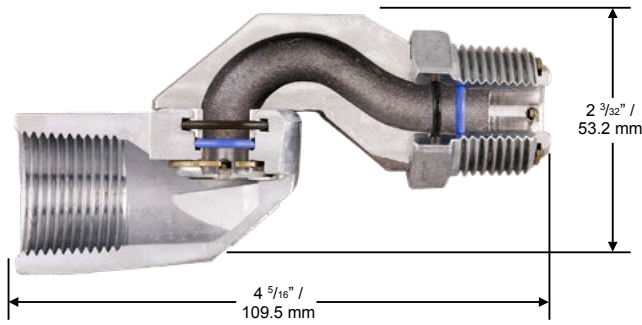

Model 002272

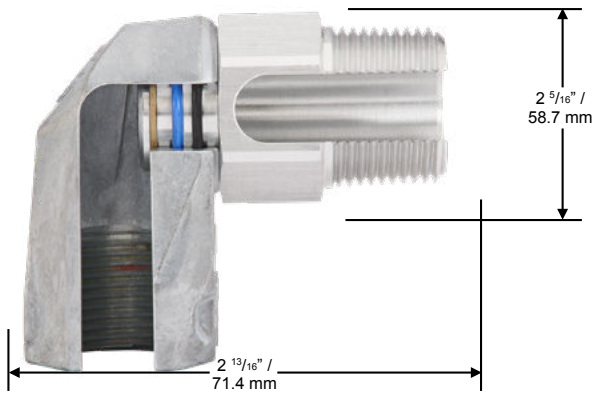

Flow Charts

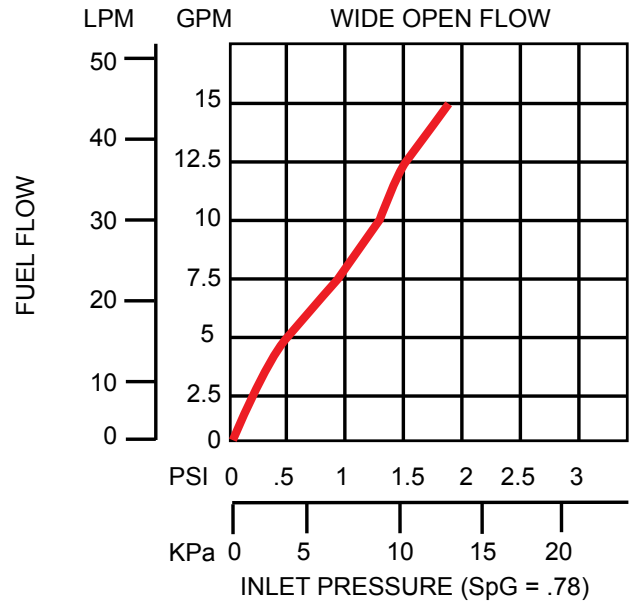

F&C High Volume Swivels

For standard fueling applications.

Features

All Husky® Multi-Plane Swivels

- Compatible with diesel fuels and Ethanol blends through E10.
- Compact and light weight for easy handling.
- High flow rates due to laminar flow design.
- High strength step shoulder bearing diameters and impact absorbing stops.
- Double o-ring seals at each swivel provide long life at low temperatures (-40° F/C).

Husky® High Volume Multi-Plane Swivels

- Multi-Plane, full 360° spherical rotation for easy movement of nozzle.
- For use with high flow nozzles with flow rates up to 100 gpm/ 378 Lpm.
- Raised stainless steel ball bearings provide easy joint movement, greatly improving ease of swivel when used on higher pressure systems.
- 75% less back pressure.

Husky® Multi-Plane Restricted Swivels

- Multi-Plane, 210° spherical rotation at the swivel nut.

Model No.	Size	Thread	Type	Shipping Wt Lbs/Kg
000087	1" M x 1" F	NPT	Multi-Plane Swivel	.96/.43
000087R	1" M x 1" F	NPT	Multi-Plane Swivel For Retail	.96/.43
004860	1" M x 1" F	NPT	High Flow Multi-Plane Swivel	1.4/.63
004860R	1" M x 1" F	NPT	High Flow Multi-Plane Swivel For Retail	1.4/.63
000095	1" M x 1" F	NPT	70° Pump Swivel	.76/.34
003395	1" M x 1" F	NPT	Restricted Multi-Plane Swivel	.93/.42
003306	1" M x 1" F	BSPP	Multi-Plane Swivel	1.1/.49
003306A*	1" M x 1" F	BSPP	Multi-Plane Swivel – Atex	1.1/.49
006949	1" M x 1" F	BSPP	High Flow Multi-Plane Swivel	1.1/.49
006949A*	1" M x 1" F	BSPP	High Flow Multi-Plane Swivel – Atex	1.1/.49

Construction

Standard

Body: High Aluminum Zinc Alloy
 Inner O-ring: Fluorsilicone
 Outer O-ring: Fluorocarbon

High Volume

Body: Aluminum, Zinc and Zinc-Plated Steel
 Inner O-ring: Fluorsilicone
 Outer O-ring: Fluorocarbon

Model 000087



Model 000095



Model 004860



WARNING: Cancer and Reproductive Harm - www.P65Warnings.ca.gov

F&C High Volume Swivels

For standard fueling applications.

Dimensions

Model 000087, 003306, and 003395

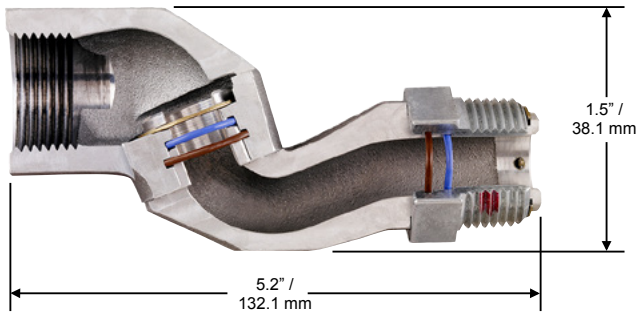

Model 004860 and 006949

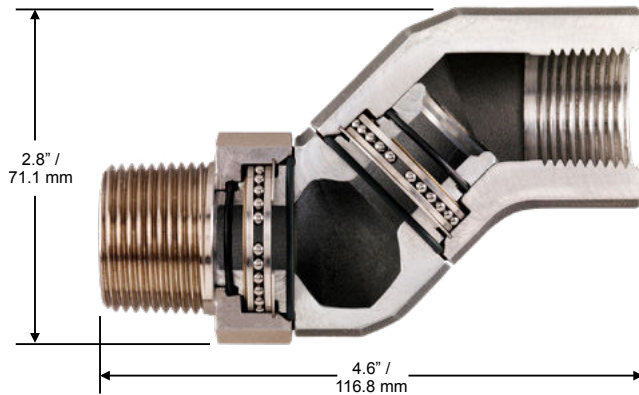

Model 000095

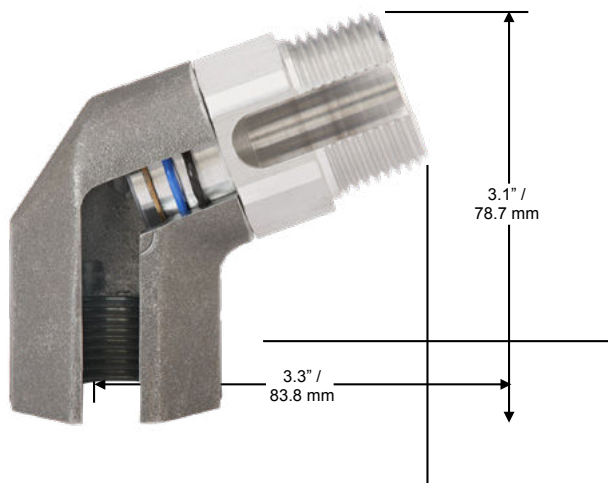

Flow Chart

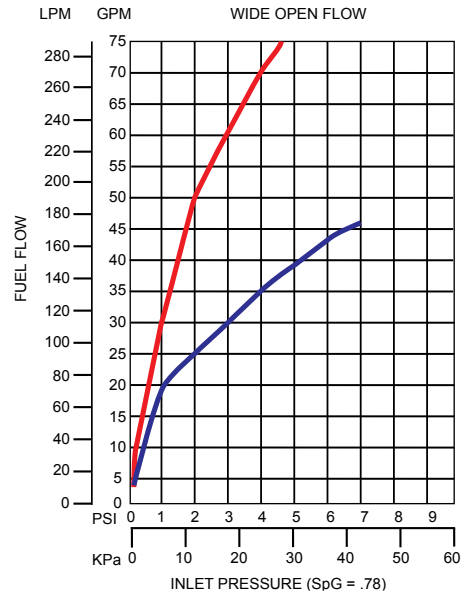

— Model 004860
 — Models 000087, 000095

Vapor Recovery Swivels

Vapor Recovery Swivel is compatible with most vacuum assist vapor recovery systems.

Features

- EVR Certified per CAB CP-201.
- 360° rotation at each swivel joint.
- Double o-rings at each swivel joint.
- Can be installed at the nozzle or at the dispenser.
- Stainless steel ball bearings and races allow for easy joint movement and reduces friction, thus extending the life of the swivel.
- Has 2 (two) plane rotation.
- Exceptional flow rate and reduced back pressure.
- Lightweight and compact.

Model No.	Size	Thread	Type	Shipping Wt Lbs/Kg
004605	M34 x 1.5"	M34	Multi-Plane Swivel	1.0 (.45)
004605A*	M34 x 1.5"	M34	Multi-Plane Swivel - Atex	1.0 (.45)
014620	1-1/4"	1-1/4" x 18	Multi-Plane Swivel, 1-1/4"	1.0 (.45)

Construction

Body: Zinc

Inlet Body: Aluminum

Swivel Nut: Electroless, Nickel Plated Aluminum or Steel

Seals: Fluorocarbon

Model VR Swivel



⚠ WARNING: Cancer and Reproductive Harm - www.P65Warnings.ca.gov

Vapor Recovery Swivels

Vapor Recovery Swivel is compatible with most vacuum assist vapor recovery systems.

Dimensions

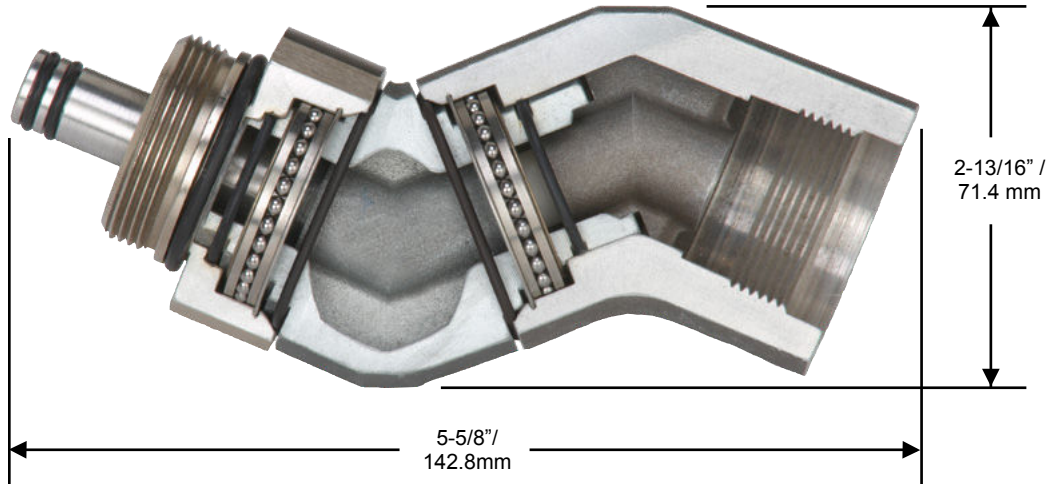

Flow Chart

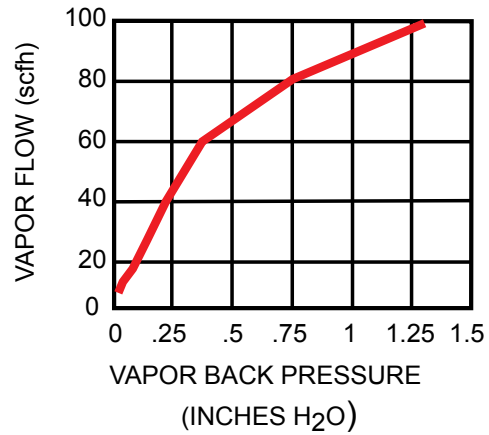
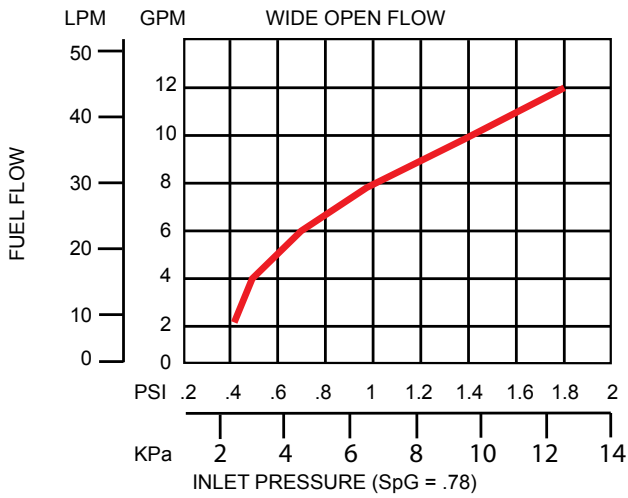

High Volume Swivels

For truck and high volume fueling.

Features

All Husky® Multi-Plane Swivels

- Compatible with diesel fuels and Ethanol blends through E10.
- Compact and light weight for easy handling.
- High flow rates due to laminar flow design.
- High strength step shoulder bearing diameters and impact absorbing stops.
- Double o-ring seals at each swivel provide long life at low temperatures (-40° F/C).

Husky® High Volume Multi-Plane Swivels

- Multi-Plane, full 360° spherical rotation for easy movement of nozzle.
- For use with high flow nozzles with flow rates up to 100 gpm/ 378 Lpm.
- Raised stainless steel ball bearings provide easy joint movement, greatly improving ease of swivel when used on higher pressure systems.
- 75% less back pressure.

Husky® Multi-Plane Restricted Swivels

- Multi-Plane, 210° spherical rotation at the swivel nut.

Model No.	Size	Thread	Type	Shipping Wt Lbs/Kg
000087	1" M x 1" F	NPT	Multi-Plane Swivel	.96/.43
004860	1" M x 1" F	NPT	High Flow Multi-Plane Swivel	1.4/.63
000095	1" M x 1" F	NPT	70° Pump Multi-Plane Swivel	.76/.34
003395	1" M x 1" F	NPT	90° Swivel	.93/.42
003306	1" M x 1" F	BSPP	Multi-Plane Swivel	1.1/.49
003306A*	1" M x 1" F	BSPP	Multi-Plane Swivel – Atex	1.1/.49
006949	1" M x 1" F	BSPP	High Flow Multi-Plane Swivel	1.1/.49
006949A*	1" M x 1" F	BSPP	High Flow Multi-Plane Swivel – Atex	1.1/.49

Construction

Standard

Body: High Aluminum Zinc Alloy
 Inner O-ring: Fluorsilicone
 Outer O-ring: Fluorocarbon

High Volume

Body: Aluminum, Zinc and Zinc-Plated Steel
 Inner O-ring: Fluorsilicone
 Outer O-ring: Fluorocarbon

Model 004860



Model 000095



Model 000087



! WARNING: Cancer and Reproductive Harm - www.P65Warnings.ca.gov

High Volume Swivels

For truck and high volume fueling.

Dimensions

Model 000087, 003306, and 003395

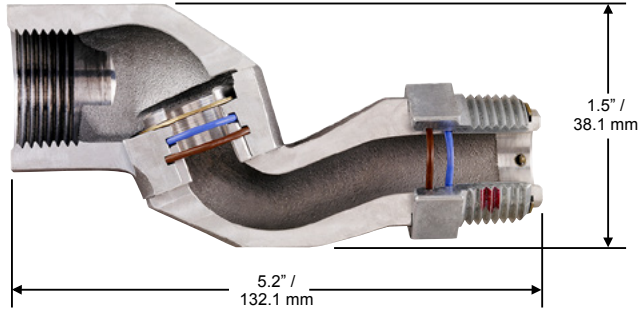

Model 004860 and 006949

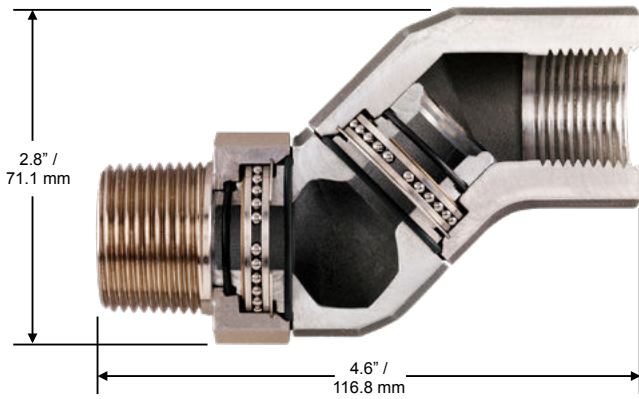

Model 000095

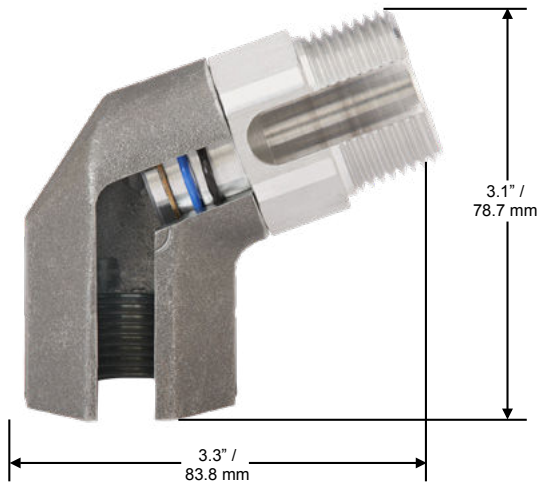

Flow Chart

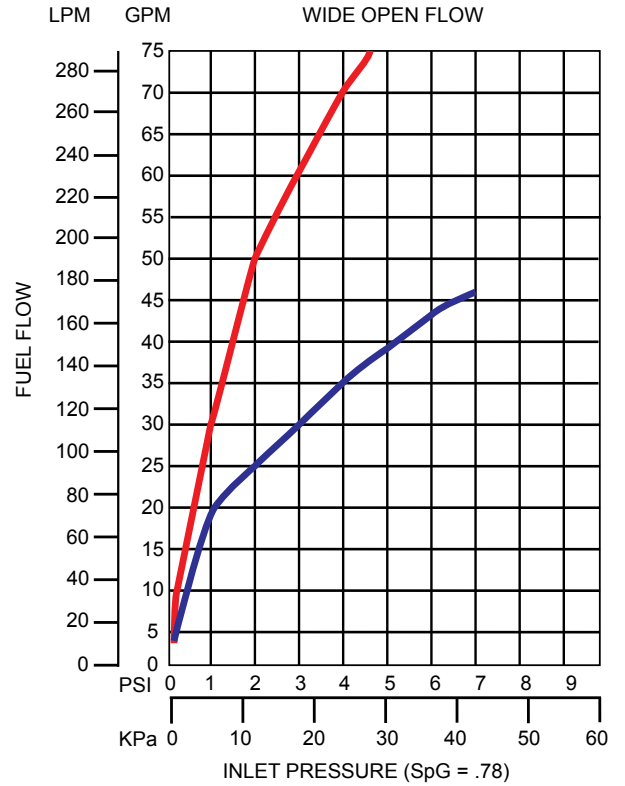

— Model 004860, 006949
 — Models 000087, 000095

Ultra High Flow Swivels

Husky® high volume delivery swivels make it easier to manipulate the long, heavy hoses used on bulk delivery systems.

Features

- Prevents kinking and twisting of hose.
- Unique stainless steel ball bearing design provides easier joint movement during high pressure applications.
- Easier to angle the nozzle into fill openings.

Model 005265



Model No.	Size	Thread	Type	Shipping Wt Lbs/Kg
005235	1¼" F x 1¼" M	NPT	Single Plane Swivel	1.4/.65
005240	1¼" F x 1½" M	NPT	Single Plane Swivel	1.4/.65
005265	1½" F x 1¼" M	NPT	Single Plane Swivel	1.4/.65
005266	1½" F x 1½" M	NPT	Single Plane Swivel	1.4/.65
005754	1¼" F x 1½" M	BSPP	Single Plane Swivel	1.4/.65

Construction

Body: Aluminum
Seals: Fluorocarbon



⚠ WARNING: Cancer and Reproductive Harm - www.P65Warnings.ca.gov

Ultra High Flow Swivels

Husky® high volume delivery swivels make it easier to manipulate the long, heavy hoses used on bulk delivery systems.

Dimensions

Model 005235, 005240, 005265 and 005266

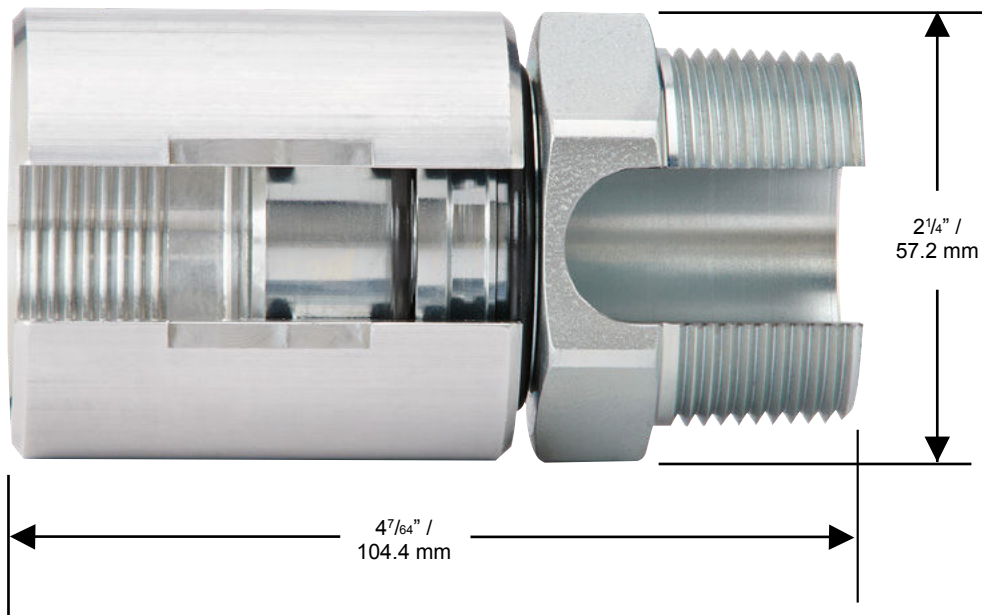

DEF Swivels

Diesel Exhaust Fluid Inline Swivels.

Features

- Full 360° rotation for easy movement of nozzle.
- Relieves kinking and twisting of the hose.
- High flow rate featuring laminar flow design.
- Compact for easy handling.
- Unique to Husky® products, the steel ball bearing design provides easier joint movement during high pressure applications.
- DEF compatible thread sealant required for NPT threads only

Construction

Body: Stainless Steel, Anodized Aluminum
 Seals: Fluorocarbon
 Nut: Stainless Steel

Model No.	Size	Thread	Type	Shipping Wt Lbs/Kg
007269	1" M x 1" M	BSPP	Inline Swivel	.60/.27
007275	1" M x M34 M	BSPP/M34	Inline Swivel	.62/.28
007282	3/4" M x 3/4" Hose Barb	BSPP	Roller Bearing Inline Swivel	.42/.19
007467	1" F x 1" M	BSPP	Inline Swivel	.66/.30
008510	1" M x 1" F	BSPP/NPT	Inline Swivel	.66/.30
008822	1" F x 1" M	BSPP	Face Seal Inline Swivel	.66/.30
010936	3/4" M x 3/4" Hose Barb	BSPP	Inline Swivel	.42/.19
012604^	3/4" M x 3/4" F	NPT	Roller Bearing Inline Swivel	.23/.10
012656^	3/4" M x 3/4" F	BSPP	Roller Bearing Inline Swivel	.23/.10

^ NOT LISTED

Accessories

Model No.	Description
007406	3/4" BSPP Seal Kit Assembly
007407	1" BSPP Seal Kit Assembly

Model 007269



Model 007275



Model 012604/012656



Model 007467/008510/008822



Model 007282/010936



^ NOT LISTED

WARNING: Cancer and Reproductive Harm - www.P65Warnings.ca.gov

DEF Swivels

Diesel Exhaust Fluid Inline Swivels.

Dimensions

Model 007269

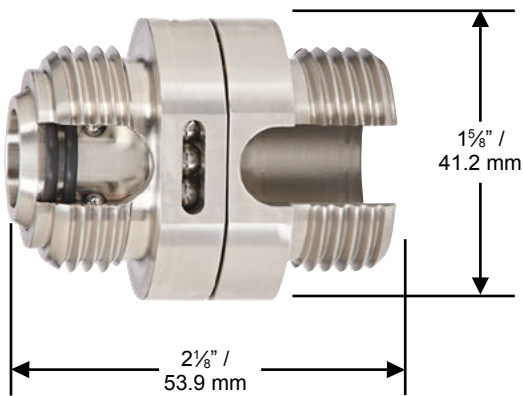

Model 007282/010936

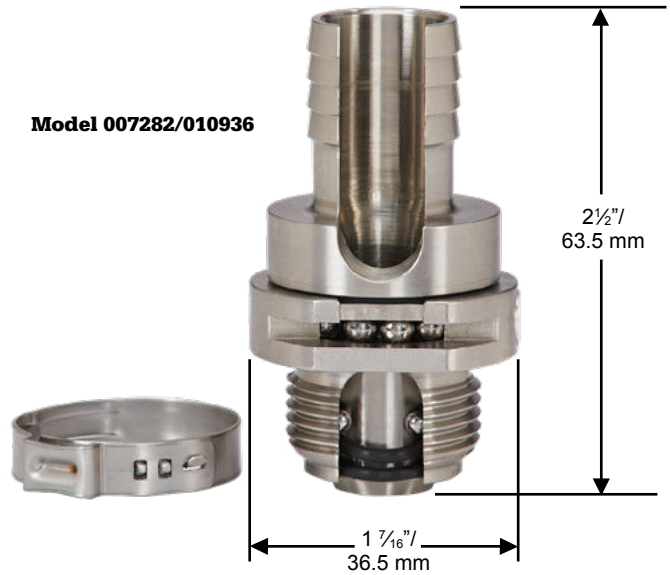

Model 007467/008510/008822

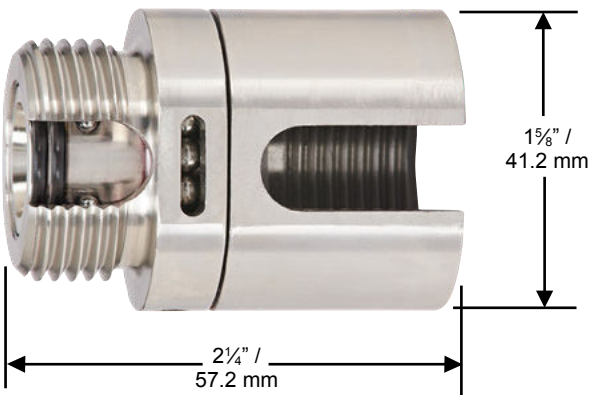

Model 007275

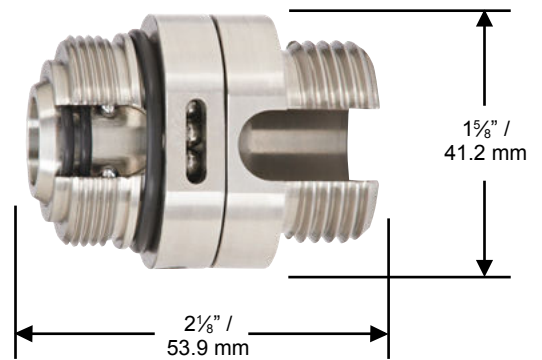

E85 Swivel

Husky Model 6350 Multi-Plane Swivel.

Features

- Multi-Plane, Full 360° spherical rotation for easy movement of nozzle.
- Compatible with unleaded, diesel, and all Ethanol blends through E100.
- Compatible with fuels containing alcohol.
- High flow rate due to laminar flow design.
- Compact and light weight for easy handling.
- Double o-ring seals at each swivel provide long life and low temperature (-40° F/C) performance.
- High strength step shoulder bearing diameters and impact absorbing stops.

Model No.	Size	Thread	Type	Shipping Wt Lbs/Kg
6350	3/4" M x 3/4"	NPTF	Multi-Plane Swivel	.44/.19

Construction

Body: Aluminum with Electroless Nickel Plating

Inner O-ring: Fluorosilicone

Outer O-ring: Fluorocarbon

Model 6350



E85 Swivel

Husky Model 6350 Multi-Plane Swivel.

Dimensions

Model 6350

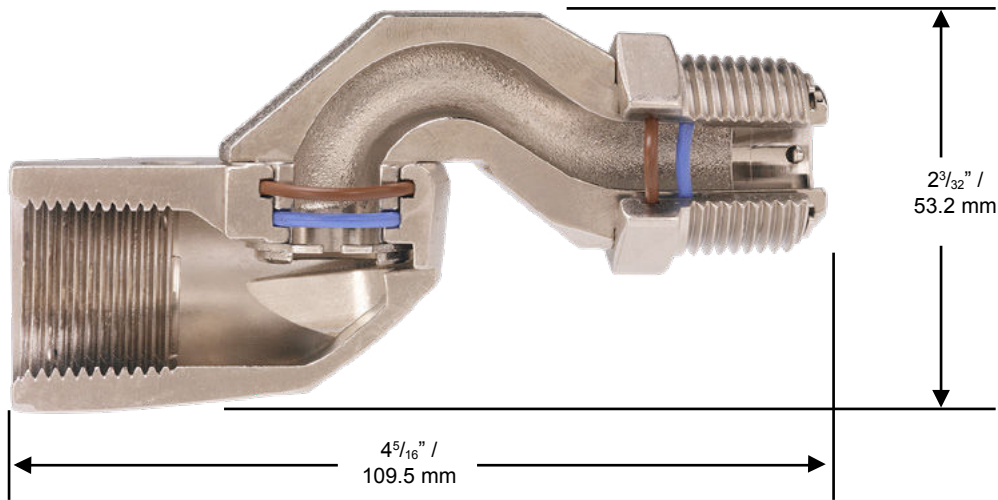

Flow Chart

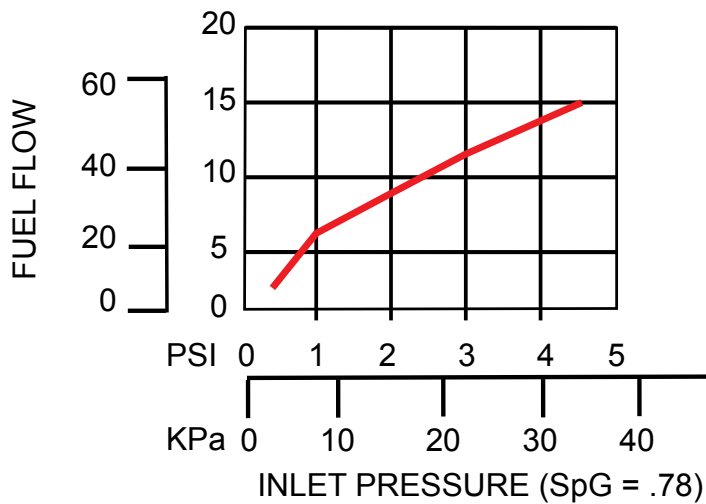



GENERAL FUELING PRODUCTS

Safe-T-Breaks®

Standard **STB**

All Husky® Safe-T-Breaks® stop the flow of fuel on both sides of the separation and have passed the demanding UL test requirements on separations without leaking or failing.

Models 003360 & 003385

- Retains UL listing after reconnection.
- Features a pre-loaded spring and a single turn wave spring that enables valve to resist sudden pressure build-up in the hose causing nuisance separations.
- Separates using ball bearings and latch ring at less than 200 lbf / 889.6 N which minimizes “backlash” force of separation, reducing damage to equipment.

Model 005230

- Retains UL listing after reconnection.
- Uses the same pre-loaded spring and a single turn wave spring as Model 003360.
- Separates using ball bearings and latch ring at less than 115 lbf / 511.5 N.

Model 002273 & 002774

- Light-weight, inexpensive and disposable.
- Same instant-closing dual poppet check valve design as Model 003360.
- Separates using shear pins at less than 300 lbf / 1334.4 N.

Model 006130

- Internal Pressure Compensating Chamber (PCC) that prevents “line shock” nuisance separations.
- Same instant-closing dual poppet check valve as Model 003360.
- Separates using shear pins at less than 225 lbf / 1000.8 N.

Models 015130 & 015349

- Internal Pressure Compensating Chamber (PCC) that prevents “line shock” nuisance separations.
- Same instant-closing dual poppet check valve as Model 002276.
- Features a pre-loaded spring and a single turn wave spring that enables valve to resist fatigue from repeated hose stretching.
- Separates using ball bearings and latch ring at less than 250 lbf / 1,112.1 N.

Model 002273



Model 003360



Model 006130



Reconnectable with NPT

MODEL NO.	DESCRIPTION	SHIPPING WEIGHT LBS (KG)
003360**	¾" F x ¾" F Reconnectable Safe-T-Break® with scuff guard	0.59 (0.26)
005230**	¾" F x ¾" F Reconnectable Low-Pull Safe-T-Break® with scuff guard	0.59 (0.26)

Non-reconnectable with NPT

MODEL NO.	DESCRIPTION	SHIPPING WEIGHT LBS (KG)
002273	¾" F x ¾" F Non-Reconnectable Safe-T-Break®	0.78 (0.35)
006130**	¾" F x ¾" F PCC Non-Reconnectable Safe-T-Break® with scuff guard	0.52 (0.23)
015130**	¾" F x ¾" F LH PCC Non-Reconnectable Safe-T-Break® with scuff guard	0.52 (0.23)

Reconnectable with BSPP

MODEL NO.	DESCRIPTION	SHIPPING WEIGHT LBS (KG)
003385**	¾" F x ¾" F Reconnectable Safe-T-Break® with scuff guard	0.57 (0.25)

Non-reconnectable with BSPP

MODEL NO.	DESCRIPTION	SHIPPING WEIGHT LBS (KG)
002274	¾" F x ¾" F Non-Reconnectable Safe-T-Break®	0.73 (0.33)
002774A*	¾" F x ¾" F Non-Reconnectable Safe-T-Break® - Atex	0.73 (0.33)
015349**	¾" F x ¾" F LH PCC Non-Reconnectable Safe-T-Break®	0.52 (0.23)

**See page 2 for guard color options

Construction

RECONNECTABLE SAFE-T-BREAKS®	
Body	Aluminum
Seals	Fluorocarbon
Springs	Stainless Steel
	Stainless steel load and latch spring reverse mechanism
	Hardened stainless steel latch ring and balls
NON-RECONNECTABLE SAFE-T-BREAKS®	
Body	Zinc Alloys and Aluminum

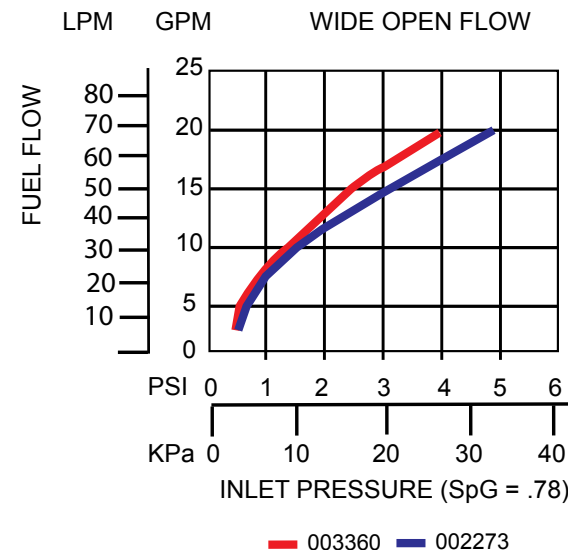

0518
II 1 G
EN 13617-2

⚠ WARNING: Cancer and Reproductive Harm - www.P65Warnings.ca.gov

Standard **STB**

All Husky® Safe-T-Breaks® stop the flow of fuel on both sides of the separation and have passed the demanding UL test requirements on separations without leaking or failing.

Dimensions and System Options

Guards

MODEL NO.	DESCRIPTION
003096**	Scuff Guard for Model #003360, 006130 and 005230
006503**	Dispenser Scuff Guard for Model #002273 and 002774
003098	Scuff Guard for Model #015130 & 015349

Accessories, Testing and Maintenance

MODEL NO.	DESCRIPTION
007000	Safe-T-Break® Drain Cup
003813	Safe-T-Break® Demonstration Kit

Guard Color Chart

COLOR	SUFFIX	COLOR	SUFFIX	COLOR <i>CUSTOM</i>	SUFFIX
Blue	-01	Gold	-08	Amoco Blue	-07 <i>CUSTOM</i>
Red	-02	Silver	-09	Apple Green	-18 <i>CUSTOM</i>
Green	-03	BP Green	-16	Purple	-19 <i>CUSTOM</i>
Black	-04	M Blue	-25	Pink	-20 <i>CUSTOM</i>
Yellow	-05	Orange	-39	BPS Green	-22 <i>CUSTOM</i>
White	-06				

Scuff Guards are to be ordered with the corresponding guard color option added to the model number. Example: If BLUE guards are desired, add guard color option -01 to the model number (159504-01). For custom colors, a minimum order of 4,000 guards will be required.

Model 003360



Model 006130

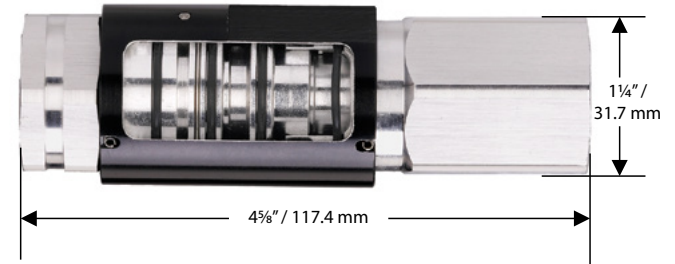

Model 002273

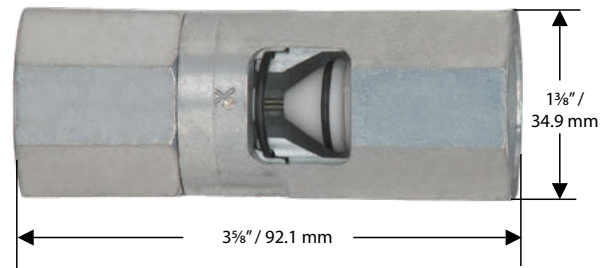

MAG MAGBREAK®

All Husky® Safe-T-Breaks® stop the flow of fuel on both sides of the separation and have passed the demanding UL test requirements on separations without leaking or failing.

G2 Magbreak®

- Low scuff, High impact resistant polymer housing
- 15% Smaller housing diameter
- Available in 3/4" Female NPT or BSP threads
- 40% Lighter than Original Magbreak®
- Separates at less than 200 pounds (889 N) pull force
- Can be separated using two flathead screwdrivers allowing for easier maintenance on hanging hardware
- Assurance of proper reconnection using a simple "Twist to Lock" feature.
- Line shock absorbing design
- Retains UL listing after reconnection

Magbreak®

- Low scuff, High impact resistant polymer housing
- Available in 3/4" or 1" Female NPT or BSP threads
- Lighter than competing magnetic breakaways
- Separates at less than 225 pounds (1,000 N) pull force
- Can be separated using two flathead screwdrivers allowing for easier maintenance on hanging hardware
- Assurance of proper reconnection using a simple "Twist to Lock" feature.
- Line shock absorbing design
- Retains UL listing after reconnection

G2 Magbreak®

MODEL NO.	DESCRIPTION	SHIPPING WEIGHT LBS (KG)
008330	G2 Magbreak @ 3/4" F NPT(separates at less than 200 pounds pull force)	.72 (.32)
009910	G2 Magbreak @ 3/4" F BSP(separates at less than 200 pounds pull force)	.72 (.32)

Magbreak®

MODEL NO.	DESCRIPTION	SHIPPING WEIGHT LBS (KG)
008331	Magbreak @ 1" F NPT CK(separates at less than 225 pounds pull force)	1.09 (.50)
009911	G2 Magbreak @ 1" F BSP(separates at less than 200 pounds pull force)	1.09 (.50)
010328	Magbreak @ 3/4" F NPT CK(separates at less than 225 pounds pull force)	1.21 (.55)

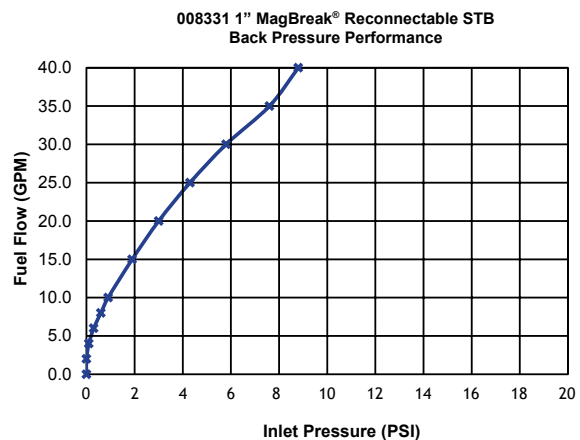
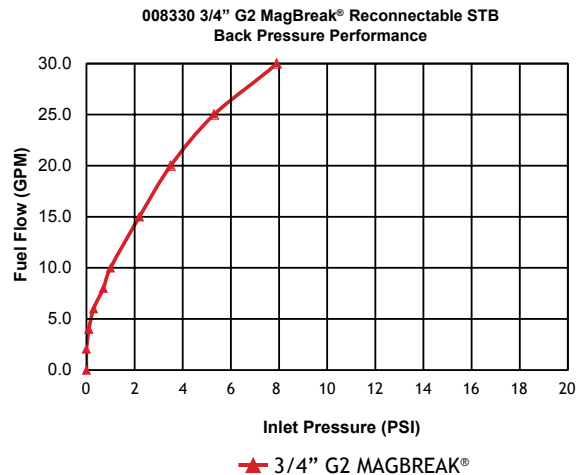

WARNING: Cancer and Reproductive Harm - www.P65Warnings.ca.gov

MAG MAGBREAK®

All Husky® Safe-T-Breaks® stop the flow of fuel on both sides of the separation and have passed the demanding UL test requirements on separations without leaking or failing.

Dimensions and System Options

Replacement Parts

MODEL NO.	DESCRIPTION
008630	MAGBREAK LOWER HALF 008330
008631	MAGBREAK LOWER HALF 008331

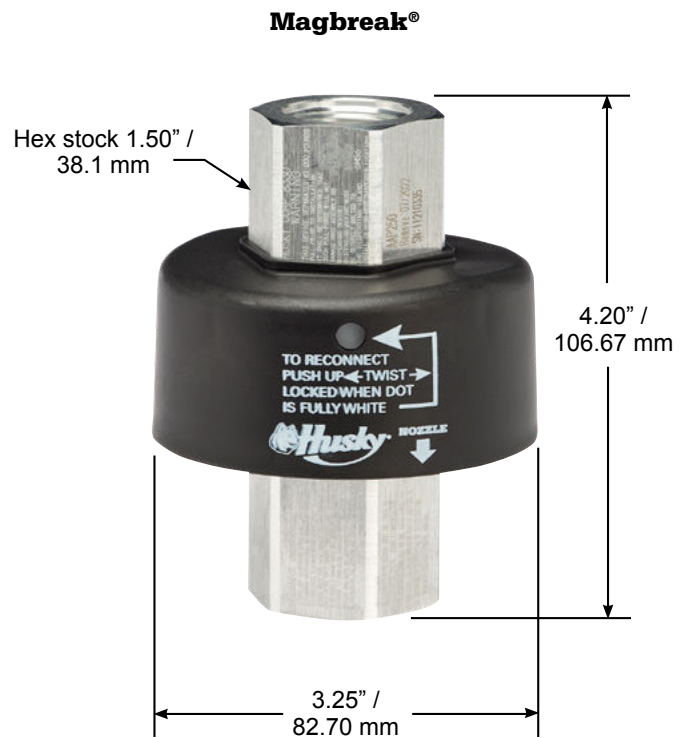

F&C Standard **STB**

All Husky® Safe-T-Breaks® stop the flow of fuel on both sides of the separation and have passed the demanding UL test requirements on separations without leaking or failing.

Models 003360 & 003385

- Retains UL listing after reconnection.
- Features a pre-loaded spring and a single turn wave spring that enables valve to resist sudden pressure build-up in the hose causing nuisance separations.
- Separates at less than 200 lbf / 889.6 N which minimizes “backlash” force of separation, reducing damage to equipment.

Model 005230

- Retains UL listing after reconnection.
- Uses the same pre-loaded spring and a single turn wave spring as Model 003360.
- Separates at less than 115 lbf / 511.5 N.

Model 002273 & 002774

- Light-weight, inexpensive and disposable.
- Same instant-closing dual poppet check valve design as Model 003360.
- Separates at less than 300 lbf / 1334.4 N.

Model 006130

- Internal Pressure Compensating Chamber (PCC) that prevents “line shock” nuisance separations.
- Same instant-closing dual poppet check valve as Model 003360.
- Separates at less than 225 lbf / 1000.8 N.

Reconnectable with NPT

MODEL NO.	DESCRIPTION	SHIPPING WEIGHT LBS (KG)
003360**	¾" F x ¾" F Reconnectable Safe-T-Break® with scuff guard	0.59 (0.26)
005230**	¾" F x ¾" F Reconnectable Low-Pull Safe-T-Break® with scuff guard	0.59 (0.26)
03360R	¾" F x ¾" F Reconnectable Safe-T-Break® With Scuff Guard For Retail	0.59 (0.26)

Non-reconnectable with NPT

MODEL NO.	DESCRIPTION	SHIPPING WEIGHT LBS (KG)
002273	¾" F x ¾" F Non-Reconnectable Safe-T-Break®	0.78 (0.35)
006130**	¾" F x ¾" F PCC Non-Reconnectable Safe-T-Break® with scuff guard	0.52 (0.23)
002273R	¾" F x ¾" F Non-Reconnectable Safe-T-Break® For Retail	0.52 (0.23)

Reconnectable with BSPP

MODEL NO.	DESCRIPTION	SHIPPING WEIGHT LBS (KG)
003385**	¾" F x ¾" F Reconnectable Safe-T-Break® with scuff guard	0.57 (0.25)

Non-reconnectable with BSPP

MODEL NO.	DESCRIPTION	SHIPPING WEIGHT LBS (KG)
002774	¾" F x ¾" F Non-Reconnectable Safe-T-Break®	0.73 (0.33)
002774A*	¾" F x ¾" F Non-Reconnectable Safe-T-Break® - Atex	0.73 (0.33)

**See page 2 for guard color options



Model 003600



Model 006130



Model 002273

Construction

RECONNECTABLE SAFE-T-BREAKS®

Body	Aluminum
Seals	Fluorocarbon
Springs	Stainless Steel Stainless steel load and latch spring reverse mechanism Hardened stainless steel latch ring and balls

NON-RECONNECTABLE SAFE-T-BREAKS®

Body	Zinc Alloys and Aluminum
------	--------------------------

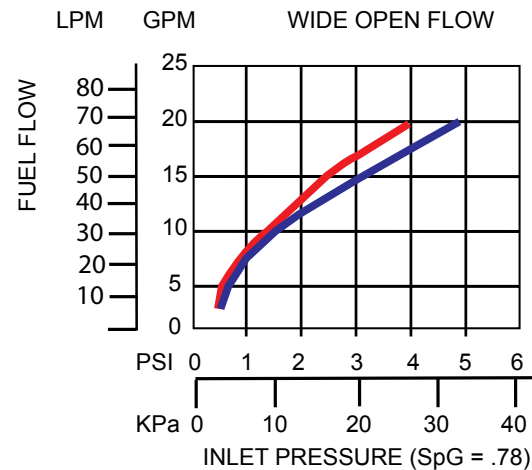

— 003360 — 002273



0518
II 1 G
EN 13617-2

⚠ WARNING: Cancer and Reproductive Harm - www.P65Warnings.ca.gov

F&C Standard **STB**

All Husky® Safe-T-Breaks® stop the flow of fuel on both sides of the separation and have passed the demanding UL test requirements on separations without leaking or failing.

Dimensions and System Options

Guards

MODEL NO.	DESCRIPTION
003096**	Scuff Guard for Model 003360, 006130 and 005230
006503**	Dispenser Scuff Guard for Model 002273 and 002774

Accessories, Testing and Maintenance

MODEL NO.	DESCRIPTION
007000	Safe-T-Break® Drain Cup
003813	Safe-T-Break® Demonstration Kit

Guard Color Chart

COLOR	SUFFIX	COLOR	SUFFIX	COLOR <i>CUSTOM</i>	SUFFIX
Blue	-01	Gold	-08	Amoco Blue	-07 <i>CUSTOM</i>
Red	-02	Silver	-09	Apple Green	-18 <i>CUSTOM</i>
Green	-03	BP Green	-16	Purple	-19 <i>CUSTOM</i>
Black	-04	M Blue	-21	Pink	-20 <i>CUSTOM</i>
Yellow	-05	Orange	-39	BPS Green	-22 <i>CUSTOM</i>
White	-06				

Scuff Guards are to be ordered with the corresponding guard color option added to the model number. Example: If BLUE guards are desired, add guard color option -01 to the model number (159504-01). For custom colors, a minimum order of 4,000 guards will be required.

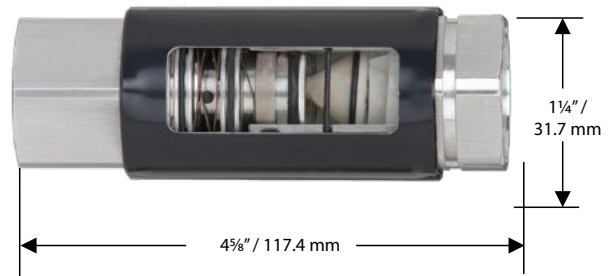
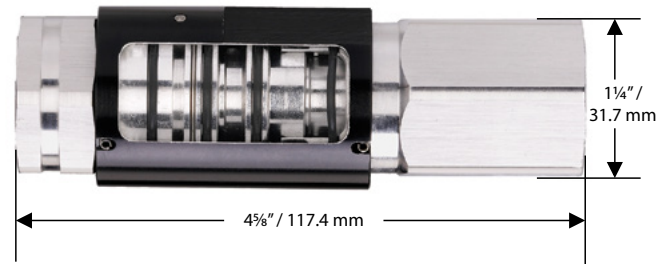
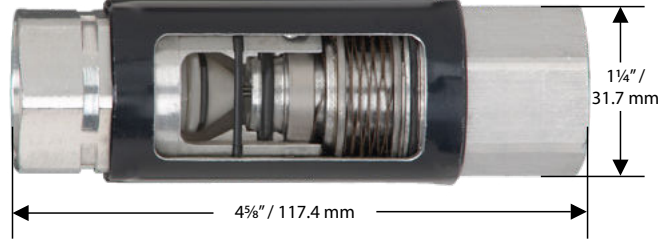

F&C High Volume **STB**

All Husky® Safe-T-Breaks® stop the flow of fuel on both sides of the separation and have passed the demanding UL test requirements on separations without leaking or failing.

Models 002276, 003076 & 003076A

- Retains UL listing after reconnection.
- Internal pressure balancing chamber prevents “line shock” nuisance separations.
- Separates using ball bearings and latch ring at less than 200 lbf / 889.6 N which minimizes “backlash” force of separation, reducing damage to equipment.

Model 005231

- Retains UL listing after reconnection.
- Uses the same internal pressure balancing chamber as Model 002276.
- Separates using ball bearings and latch ring at less than 115 lbf / 511.5 N.

Model 005812 & 006914

- Light-weight, inexpensive and disposable.
- Same instant-closing dual poppet check valve design as Model 002276.
- Separates using shear pins between 300 lbf/ 1334.5 N to 350 lbf/ 1556.9 N.

Model 006301

- Internal Pressure Compensating Chamber (PCC) that prevents “line shock” nuisance separations.
- Same instant-closing dual poppet check valve as Model 002276.
- Separates using shear pins at less than 225 lbf / 1000.8 N.

Reconnectable with NPT

MODEL NO.	DESCRIPTION	SHIPPING WEIGHT LBS (KG)
002276	1" F x 1" F Reconnectable Safe-T-Break®	.75 (.34)
005231	1" F x 1" F Reconnectable Low-Pull Safe-T-Break®	.75 (.34)
002276R	1" F x 1" F Reconnectable Safe-T-Break®	.75 (.34)

Non-reconnectable with NPT

MODEL NO.	DESCRIPTION	SHIPPING WEIGHT LBS (KG)
005812	1" F x 1" F Non-Reconnectable Safe-T-Break®	.61 (.27)
006301	1" F x 1" F PCC Non-Reconnectable Safe-T-Break®	.69 (.31)
005812R	1" F x 1" F Non-Reconnectable Safe-T-Break®	.69 (.31)

Reconnectable with BSP

MODEL NO.	DESCRIPTION	SHIPPING WEIGHT LBS (KG)
003076	1" F x 1" F Reconnectable Safe-T-Break®	.75 (.34)
003076A*	1" F x 1" F Reconnectable Safe-T-Break® - Atex	.75 (.34)

Non-reconnectable with BSP

MODEL NO.	DESCRIPTION	SHIPPING WEIGHT LBS (KG)
006914	1" F x 1" F Non-Reconnectable Safe-T-Break®	.61 (.27)

Construction

Reconnectable Safe-T-Breaks®	
Body	Aluminum
Seals	Fluorocarbon
Springs	Stainless Steel Stainless steel load and latch spring reverse mechanism Hardened stainless steel latch ring and balls
Non-Reconnectable Safe-T-Breaks®	
Body	Aluminum

Model 002276



Model 005812

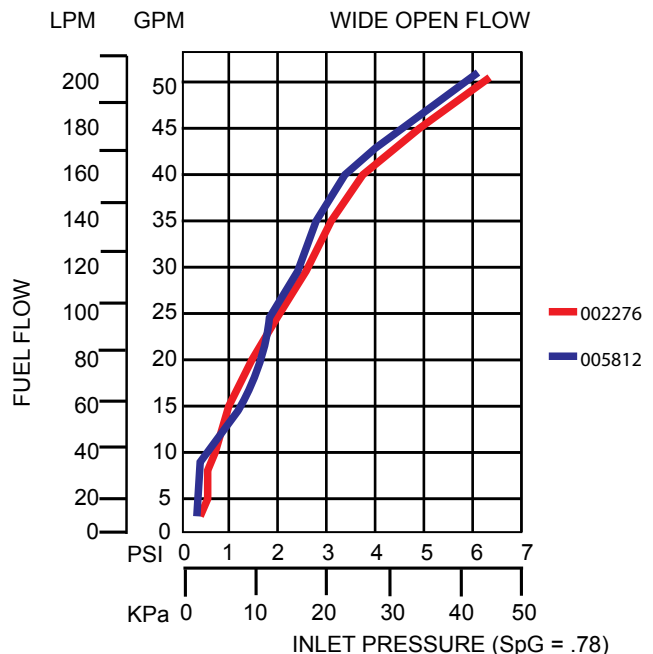

0518
II 1 G
EN 13617-2

WARNING: Cancer and Reproductive Harm - www.P65Warnings.ca.gov

F&C High Volume STB

All Husky® Safe-T-Breaks® stop the flow of fuel on both sides of the separation and have passed the demanding UL test requirements on separations without leaking or failing.

Dimensions and System Options

Guards

MODEL NO.	DESCRIPTION
003098**	Safe-T-Break® Scuff Guard

Accessories, Maintenance, and Testing

Model No.	Description
007000	Safe-T-Break® Drain Cup
003813	Safe-T-Break® Demonstration Kit

Guard Color Chart

COLOR	SUFFIX	COLOR	SUFFIX	COLOR <i>CUSTOM</i>	SUFFIX
Blue	-01	Gold	-08	Amoco Blue	-07 <i>CUSTOM</i>
Red	-02	Silver	-09	Apple Green	-18 <i>CUSTOM</i>
Green	-03	BP Green	-16	Purple	-19 <i>CUSTOM</i>
Black	-04	M Blue	-25	Pink	-20 <i>CUSTOM</i>
Yellow	-05	Orange	-39	BPS Green	-22 <i>CUSTOM</i>
White	-06				

Scuff Guards are to be ordered with the corresponding guard color option added to the model number. Example: If BLUE guards are desired, add guard color option -01 to the model number (159504-01). For custom colors, a minimum order of 4,000 guards will be required.

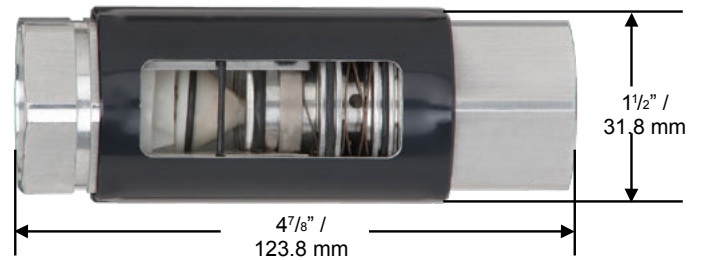
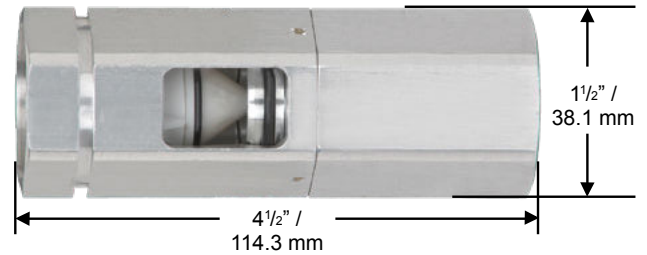

DEF Safe-T-Break®

All Husky® Safe-T-Breaks® stop the flow of fuel on both sides of the separation and have passed the demanding UL test requirements on separations without leaking or failing.

Model 007219

- Non-reconnectable Safe-T-Break®
- Low profile design.
- Thread sealant not required with BSPP threads.
- 100% DEF compatible parts.
- Instant-closing, dual poppet check valve design.
- Maximum separation of 300 lbf / 1334.5 N.
- Comes standard with guard.

Model 012070

- Reconnectable Safe-T-Break®
- Maximum separation of 200 lbf / 889.6 N.
- 100% DEF compatible parts.
- Instant-closing, dual poppet check valve design.
- Comes standard with guard.
- DEF compatible thread sealant required for 3/4" NPT threads.

Model 008216

- Reconnectable Safe-T-Break®
- Maximum separation of 200 lbf / 889.6 N.
- 100% DEF compatible parts.
- Thread sealant not required with BSPP threads.
- Instant-closing, dual poppet check valve design.
- Comes standard with guard.

Safe-T-Breaks®

MODEL NO.	DESCRIPTION	SHIPPING WEIGHT LBS (KG)
007219	1" M x 1" M Stainless Steel Non-Reconnectable Safe-T-Break®	0.90 (.40)
008216	1" M x 1" M BSPP Stainless Steel Reconnectable Safe-T-Break®	0.94 (.43)
012070^	3/4" F x 3/4" F NPT Reconnectable Safe-T-Break®	0.54 (.20)
012659^	3/4" F x 3/4" F BSPP Reconnectable Safe-T-Break®	.54 (.20)

^ NOT LISTED

Construction

Body	Stainless Steel, 012070 - Anodized Aluminum
Seals	Fluorocarbon
Inlet	1" / 25.4 mm BSPP, 012070 - 3/4" / 19.1 mm NPT

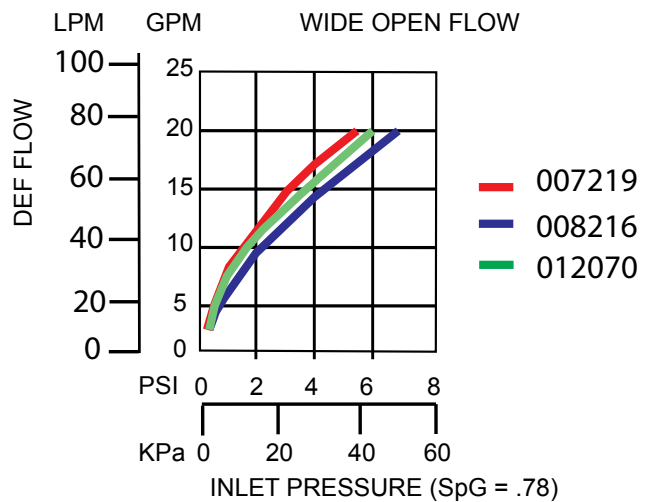

Model 008216



Model 012070/012659



Model 007219



⚠ WARNING: Cancer and Reproductive Harm - www.P65Warnings.ca.gov

DEF Safe-T-Break®

All Husky® Safe-T-Breaks® stop the flow of fuel on both sides of the separation and have passed the demanding UL test requirements on separations without leaking or failing.

Dimensions and System Options

Guards

MODEL NO.	DESCRIPTION
007224	Black Scuff Guard
006534	Dispenser Scuff Guard
003097	Scuff Guard

Accessories, Testing and Maintenance

MODEL NO.	DESCRIPTION
007407	1" BSPP Seal Kit Assembly

Model 007219

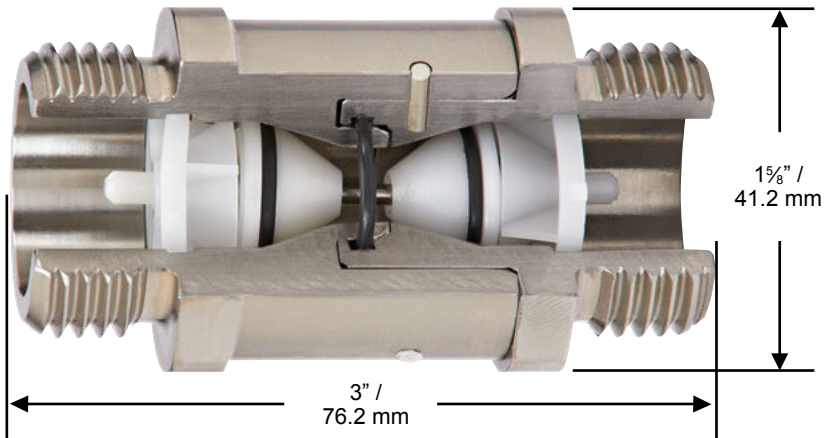

Model 012070/012659



Model 008216



High Volume STB

All Husky® Safe-T-Breaks® stop the flow of fuel on both sides of the separation and have passed the demanding UL test requirements on separations without leaking or failing.

Models 002276, 003076 & 003076A

- Retains UL listing after reconnection.
- Internal pressure balancing chamber prevents “line shock” nuisance separations.
- Separates at less than 200 lbf / 889.6 N which minimizes “backlash” force of separation, reducing damage to equipmen.

Model 005231

- Retains UL listing after reconnection.
- Uses the same internal pressure balancing chamber as Model 002276.
- Separates at less than 115 lbf / 511.5 N.

Model 005812 & 006914

- Light-weight, inexpensive and disposable.
- Same instant-closing dual poppet check valve design as Model 002276.
- Separates at less than 300 lbf / 1334.4 N.

Model 006301

- Internal Pressure Compensating Chamber (PCC) that prevents “line shock” nuisance separations.
- Same instant-closing dual poppet check valve as Model 002276.
- Separates at less than 225 lbf / 1000.8 N.

Models 015176 & 015254

- Internal Pressure Compensating Chamber (PCC) that prevents “line shock” nuisance separations.
- Same instant-closing dual poppet check valve as Model 002276.
- Features a pre-loaded spring and a single turn wave spring that enables valve to resist fatigue from repeated hose stretching.
- Separates using ball bearings and latch ring at less than 250 lbf / 1,112.1 N.

Reconnectable with NPT

MODEL NO.	DESCRIPTION	SHIPPING WEIGHT LBS (KG)
002276	1" F x 1" F Reconnectable Safe-T-Break®	.75 (.34)
005231	1" F x 1" F Reconnectable Low-Pull Safe-T-Break®	.75 (.34)

Non-reconnectable with NPT

MODEL NO.	DESCRIPTION	SHIPPING WEIGHT LBS (KG)
005812	1" F x 1" F Non-Reconnectable Safe-T-Break®	.61 (.27)
006301	1" F x 1" F PCC Non-Reconnectable Safe-T-Break®	.69 (.31)
015176	1" F x 1" F Super STB 1" Non-Reconnectable	.75 (.34)

Reconnectable with BSPB

MODEL NO.	DESCRIPTION	SHIPPING WEIGHT LBS (KG)
003076	1" F x 1" F Reconnectable Safe-T-Break®	.75 (.34)
003076A	1" F x 1" F Reconnectable Safe-T-Break® - Atex	.75 (.34)

Non-reconnectable with BSPB

MODEL NO.	DESCRIPTION	SHIPPING WEIGHT LBS (KG)
006914	1" F x 1" F Non-Reconnectable Safe-T-Break®	.61 (.27)
015254	1" F x 1" F Super STB 1" Non-Reconnectable	.75 (.34)

Construction

Reconnectable Safe-T-Breaks®	
Body	Aluminum
Seals	Fluorocarbon
Springs	Stainless Steel Stainless steel load and latch spring reverse mechanism Hardened stainless steel latch ring and balls
Non-Reconnectable Safe-T-Breaks®	
Body	Aluminum



Model 002276

Model 005812



0518
II 1 G
EN 13617-2

WARNING: Cancer and Reproductive Harm - www.P65Warnings.ca.gov

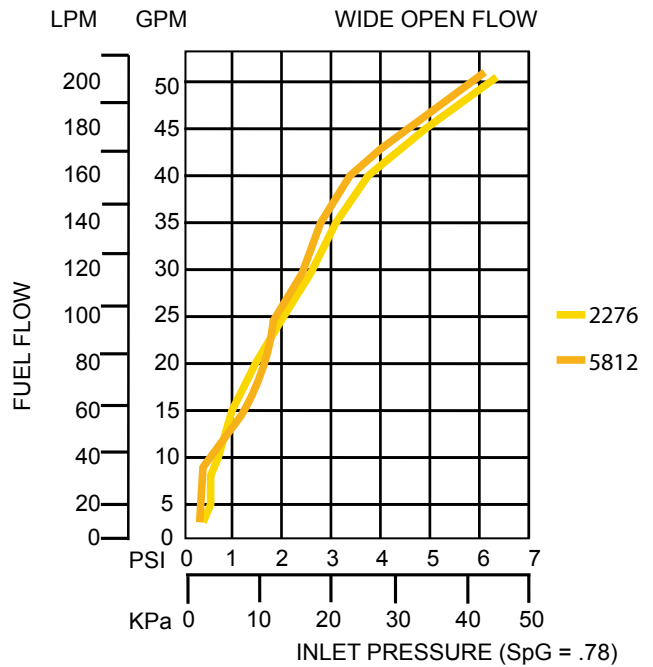

High Volume STB

All Husky® Safe-T-Breaks® stop the flow of fuel on both sides of the separation and have passed the demanding UL test requirements on separations without leaking or failing.

Dimensions and System Options

Guards

MODEL NO.	DESCRIPTION
003098**	Safe-T-Break® Scuff Guard

Accessories, Maintenance, and Testing

MODEL NO.	DESCRIPTION
007000	Safe-T-Break® Drain Cup
003813	Safe-T-Break® Demonstration Kit

Guard Color Chart

COLOR	SUFFIX	COLOR	SUFFIX	COLOR <i>CUSTOM</i>	SUFFIX
Blue	-01	Gold	-08	Amoco Blue	-07 <i>CUSTOM</i>
Red	-02	Silver	-09	Apple Green	-18 <i>CUSTOM</i>
Green	-03	BP Green	-16	Purple	-19 <i>CUSTOM</i>
Black	-04	M Blue	-25	Pink	-20 <i>CUSTOM</i>
Yellow	-05	Orange	-39	BPS Green	-22 <i>CUSTOM</i>
White	-06				

Scuff Guards are to be ordered with the corresponding guard color option added to the model number. Example: If BLUE guards are desired, add guard color option -01 to the model number (159504-01). For custom colors, a minimum order of 4,000 guards will be required.

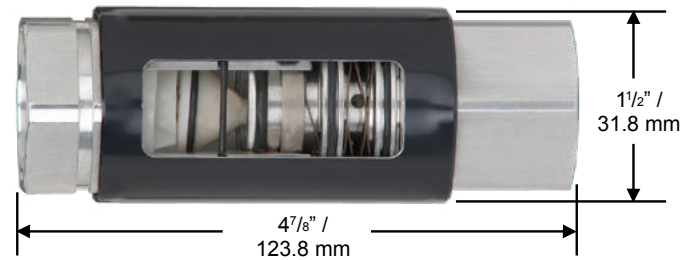
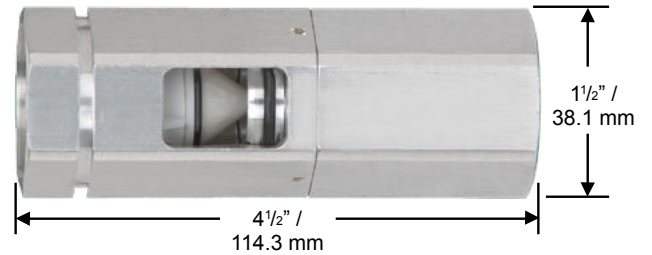

Balance Vapor **STB**

All Husky® Safe-T-Breaks® stop the flow of fuel on both sides of the separation and have passed the demanding UL test requirements on separations without leaking or failing.

Model 3360VR

- Reconnectable Safe-T-Break® for balance vapor recovery systems - coaxial hoses with fuel on the “inside”, vapor return on the “outside”.
- Unique in-line latching mechanism requires less force to reconnect Safe-T-Break® after a separation.
- Unique vapor valve stops vapors from escaping after a drive away.
- Separates at less than 200 lbf / 889.6 N to minimize backlash damage.
- Patented wave spring design minimizes nuisance breaks.

Model 005900

- Non-reconnectable Safe-T-Break® for balance vapor recovery systems - coaxial hoses with fuel on the “inside”, vapor return on the “outside”.
- Internal pressure compensating chamber isolates shear pin from line shock preventing nuisance breaks.
- Separates at less than 250 lbf / 1112.1 N to minimize backlash damage.
- Same built-in vapor valve as Model 3360VR.

Reconnectable

MODEL NO.	DESCRIPTION	SHIPPING WEIGHT LBS (KG)
3360VR**	Reconnectable Safe-T-Break®	1.3 (.5)

Non-reconnectable

MODEL NO.	DESCRIPTION	SHIPPING WEIGHT LBS (KG)
005900**	Non-Reconnectable Safe-T-Break®	1.2 (.5)

**See page 2 for guard color options

Construction

Body	Aluminum
Seals	Fluorocarbon
Springs	Stainless Steel
Threads	1 ⁷ / ₈ " x 12
Stainless steel load and latch spring reverse mechanism	
Hardened stainless steel latch ring and balls	



Model 3600VR



Model 005900

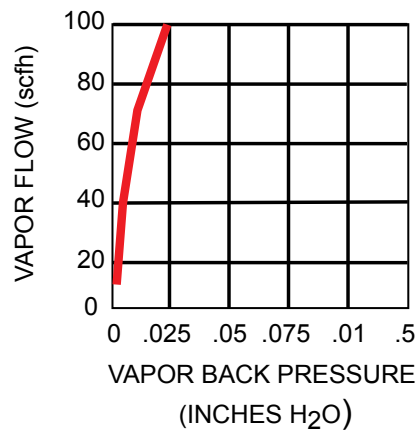

Texas Commission on Environmental Quality



Missouri Department of Natural Resources

WARNING: Cancer and Reproductive Harm - www.P65Warnings.ca.gov

Balance Vapor **STB**

All Husky® Safe-T-Breaks® stop the flow of fuel on both sides of the separation and have passed the demanding UL test requirements on separations without leaking or failing.

Dimensions and System Options

Guards

MODEL NO.	DESCRIPTION
003990**	Scuff Guard for 3360VR Safe-T-Break®
005895**	Scuff Guard for 005900 Safe-T-Break®

Accessories, Maintenance, and Testing

MODEL NO.	DESCRIPTION
007000	Safe-T-Break® Drain Cup

Guard Color Chart

COLOR	SUFFIX	COLOR	SUFFIX	COLOR <i>CUSTOM</i>	SUFFIX
Blue	-01	Gold	-08	Amoco Blue	-07 <i>CUSTOM</i>
Red	-02	Silver	-09	Apple Green	-18 <i>CUSTOM</i>
Green	-03	BP Green	-16	Purple	-19 <i>CUSTOM</i>
Black	-04	M Blue	-25	Pink	-20 <i>CUSTOM</i>
Yellow	-05	Orange	-39	BPS Green	-22 <i>CUSTOM</i>
White	-06				

Scuff Guards are to be ordered with the corresponding guard color option added to the model number. Example: If BLUE guards are desired, add guard color option -01 to the model number (159504-01). For custom colors, a minimum order of 4,000 guards will be required.

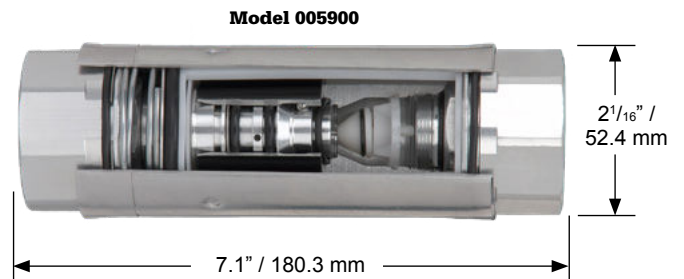
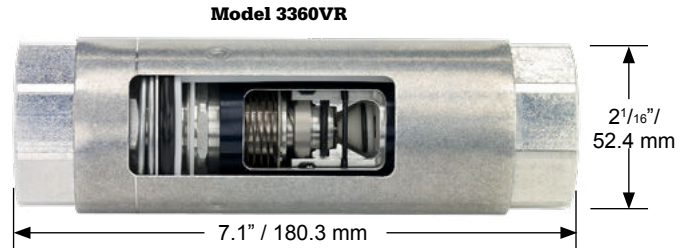

Vacuum Assist **STB**

All Husky® Safe-T-Breaks® stop the flow of fuel on both sides of the separation and have passed the demanding UL test requirements on separations without leaking or failing.

Model 004034

- Reconnectable Safe-T-Break® for the vapor assist systems: coaxial hoses with fuel “outside” hose, vapor return “inside” hose.
- EVR Certified per CARB CP-201.
- Meets the reconnect endurance test of the UL Standard 567.
- Unique vapor valve stops vapors from escaping after a drive away.
- Separates at less than 200 lbf / 889.6 N to minimize backlash damage.
- Unique pre-loaded shock absorbing wave spring minimizes nuisance breaks.

Models 004034A/005134A

- Separates between 180-337 lbf / 800-1500 N.

Model 006560

- Reconnectable Safe-T-Break in the same style and design as the Model 004034 including the same fuel/vapor paths and separation force.
- 1-1/4” X 18 Threads.
- EVR Certified per CARB CP-201.

Model 005134

- Non-reconnectable Safe-T-Breaks® in the same style and design as Model 004034, including the same fuel / vapor paths and separation force.
- EVR Certified per CARB CP-201.

Model 015377

- Non-reconnectable Safe-T-Breaks® in the same style and design as Model 006560, including the same fuel / vapor paths and separation force.
- EVR Certified per CARB CP-201.



Model 004034



Model 005134

Reconnectable

MODEL NO.	DESCRIPTION	SHIPPING WEIGHT LBS (KG)
004034	Reconnectable Safe-T-Break®	1.0 (.45)
004034A*	Reconnectable Safe-T-Break® - Atex	1.0 (.45)
006560	Reconnectable Safe-T-Break® for 1-1/4” THREADS	1.0 (.45)

Non-reconnectable

MODEL NO.	DESCRIPTION	SHIPPING WEIGHT LBS (KG)
005134	Non-reconnectable Safe-T-Break®	1.0 (.45)
005134A*	Non-reconnectable Safe-T-Break® - Atex	1.0 (.45)
015377	Non-reconnectable Safe-T-Break® 1-1/4”	1.0 (.45)

Construction

Body	Aluminum
Seals	Fluorocarbon
Springs	Stainless Steel
Springs	Stainless Steel
	Stainless steel load and latch spring reverse mechanism
	Hardened stainless steel latch ring and balls
Threads	004034, 004034A, 005134 and 005134A = M34 x 1.5 006560 and 15377= 1-1/4” x 18

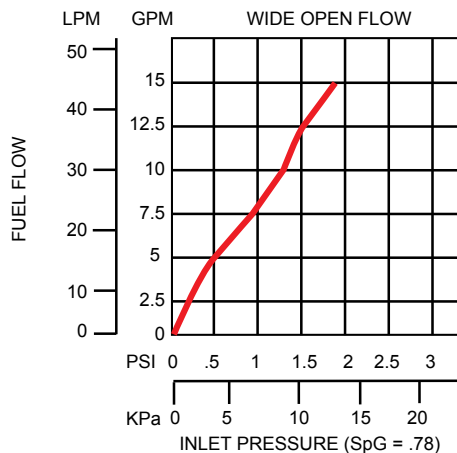
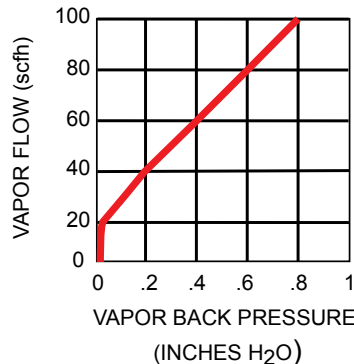

! WARNING: Cancer and Reproductive Harm - www.P65Warnings.ca.gov

Vacuum Assist **STB**

All Husky® Safe-T-Breaks® stop the flow of fuel on both sides of the separation and have passed the demanding UL test requirements on separations without leaking or failing.

Dimensions and System Options

Guards

Model No.	Description
003098**	Scuff Guard for 004034, 004034A, 005134, 005134A and 006560 Safe-T-Breaks®

Guard Color Chart

COLOR	SUFFIX	COLOR	SUFFIX	COLOR <i>CUSTOM</i>	SUFFIX
Blue	-01	Gold	-08	Amoco Blue	-07 <i>CUSTOM</i>
Red	-02	Silver	-09	Apple Green	-18 <i>CUSTOM</i>
Green	-03	BP Green	-16	Purple	-19 <i>CUSTOM</i>
Black	-04	M Blue	-25	Pink	-20 <i>CUSTOM</i>
Yellow	-05	Orange	-39	BPS Green	-22 <i>CUSTOM</i>
White	-06				

Scuff Guards are to be ordered with the corresponding guard color option added to the model number. Example: If BLUE guards are desired, add guard color option -01 to the model number (159504-01). For custom colors, a minimum order of 4,000 guards will be required.

Model 004034



Model 005134

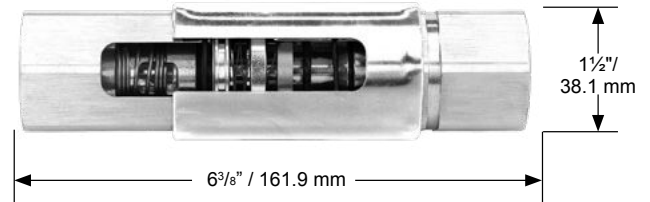

Model 006560



Model 015377

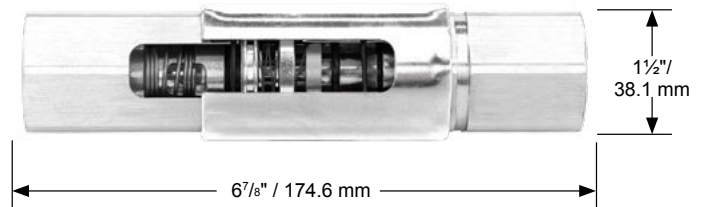

E85 Safe-T-Breaks®

All Husky® Safe-T-Breaks® stop the flow of fuel on both sides of the separation.

- Compatible with unleaded, diesel and all Ethanol blends through E85.
- Unit is lightweight, inexpensive and disposable.
- Features same instant closing dual poppet check valve design as Model 006360.
- Maximum separation of 300 lbf / 1334.5 N.



Model 006273

E85 Safe-T-Breaks®

MODEL NO.	DESCRIPTION	SHIPPING WEIGHT LBS (KG)
006273	¾" F x ¾" F Standard Non-Reconnectable Safe-T-Break®	.30 (.13)

Construction

Body	Aluminum with Electroless Nickel Plating
Seals	Fluorocarbon
Springs	Stainless Steel
Threads	¾" / 19.1 mm NPT

006273

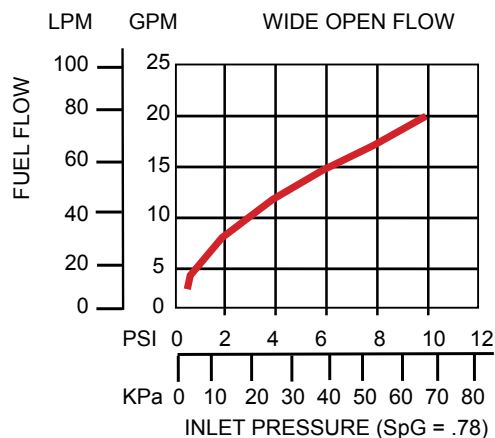

WARNING: Cancer and Reproductive Harm - www.P65Warnings.ca.gov

E85 Safe-T-Breaks®

All Husky® Safe-T-Breaks® stop the flow of fuel on both sides of the separation.

Dimensions and System Options

Accessories, Testing and Maintenance

MODEL NO.	DESCRIPTION
007000	Safe-T-Break® Drain Cup
003813	Safe-T-Break® Demonstration Kit

Model 006273

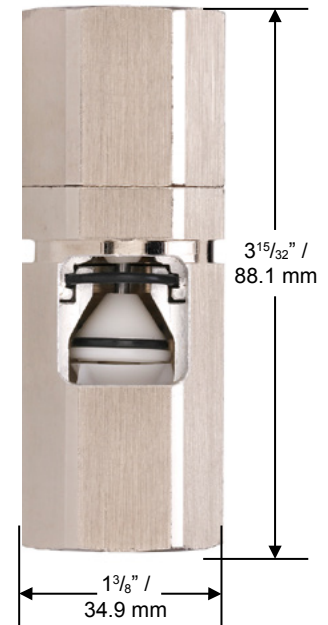

VAC Assist MAGBREAK®

SAFE-T-BREAKS®

All Husky® Safe-T-Breaks® stop the flow of fuel on both sides of the separation and have passed the demanding UL test requirements on separations without leaking or failing.

- EVR Certified per CAB CP-201.
- High impact resistant polymer housing.
- Two straight screwdrivers used to separate. For easier install and maintenance on other hanging hardware.
- Assurance of proper reconnection using a simple “twist of lock” feature.
- Low scuff housing.
- Stops flow on both sides of break.
- Reconnectable Safe-T-Break® for the vapor assist systems: coaxial hoses with fuel “outside” hose, vapor return “inside” hose.
- Unique vapor valve stops vapors from escaping after a drive away.
- Separates at less than 225 lbs / 1000.9 N to minimize backlash damage.



VAC ASSIST MAGBREAK®

Vac Assist MAGBREAK®

MODEL NO.	DESCRIPTION	SHIPPING WEIGHT LBS (KG)
008332	MAGBREAK® Coax M34 CK	1.36 (.62)
014592	MAGBREAK® Coax 1.25	1.36 (.62)

Construction

Body	Aluminum
Seals	Fluorocarbon
Springs	Stainless Steel
Threads	8332 = M34 x 1.5 and 14592 = 1-1/4" x 18

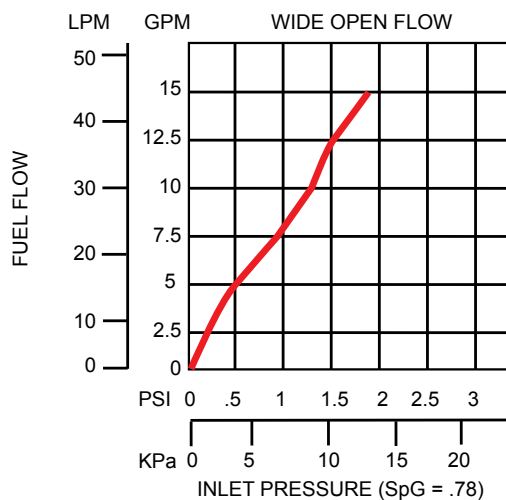
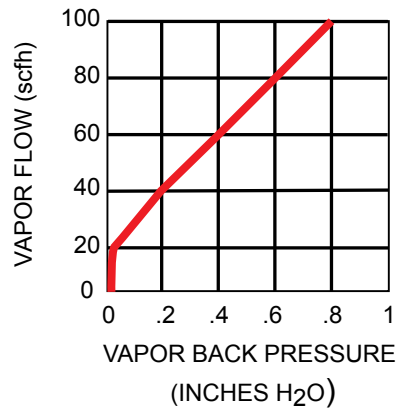

WARNING: Cancer and Reproductive Harm - www.P65Warnings.ca.gov

VAC Assist **MAGBREAK®**

All Husky® Safe-T-Breaks® stop the flow of fuel on both sides of the separation and have passed the demanding UL test requirements on separations without leaking or failing.

Dimensions and System Options

Replacement Parts

MODEL NO.	DESCRIPTION
008632	MAGBREAK LOWER HALF 008332
015416	MAGBREAK LOWER HALF 014592

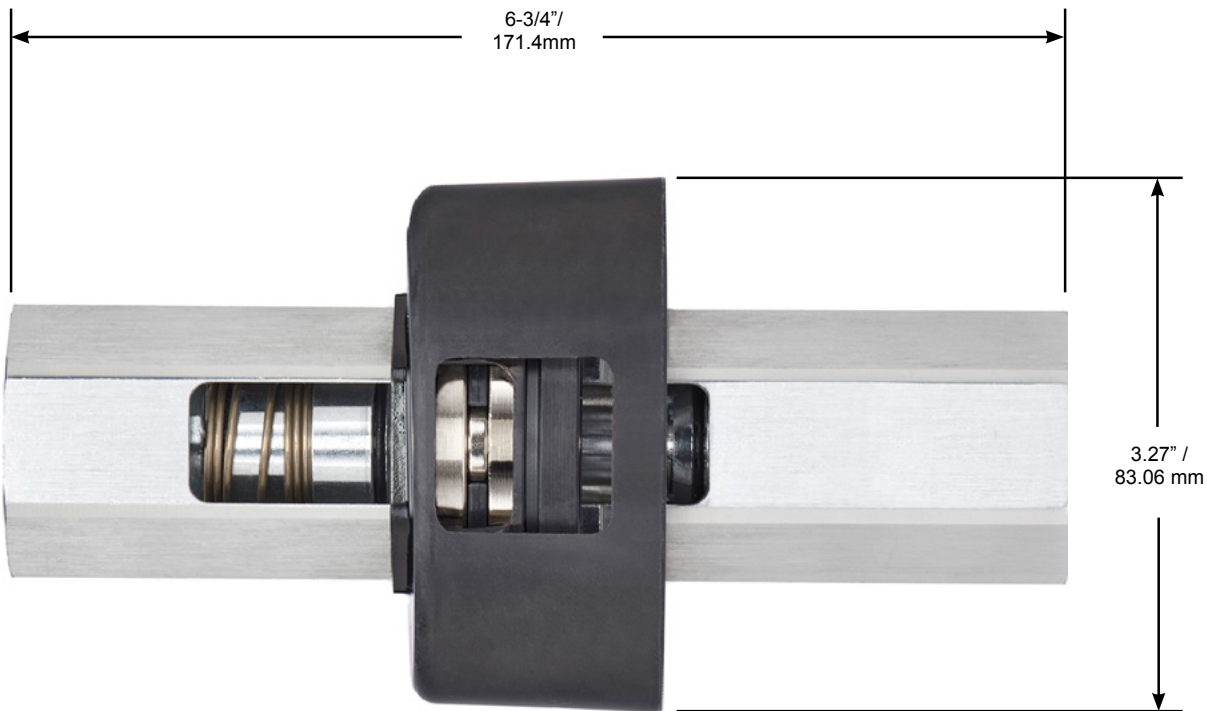

E25 Safe-T-Breaks®

All Husky® Safe-T-Breaks® stop the flow of fuel on both sides of the separation.

- Compatible with unleaded, diesel and all Ethanol blends through E25.
- Unusual interface between a pre-loaded spring and a single turn wave spring that enables valve to resist sudden pressure build-up in the hose resulting in nuisance separations.
- Retains the UL listing after being reconnected.
- Unit separates at less than 200 lbf / 889.6 N which minimizes “backlash” force of separation, reducing damage to equipment.



E25 Safe-T-Breaks®

MODEL NO.	DESCRIPTION	SHIPPING WEIGHT LBS (KG)
006360	¾" F x ¾" F Reconnectable Safe-T-Break®	.58 (.26)

Construction

Body	Aluminum with Electroless Nickel Plating
Seals	Fluorocarbon and Fluorosilicone
Springs	Stainless Steel Stainless steel load and latch spring reverse mechanism Hardened stainless steel latch ring and ball
Threads	¾" / 19.1 mm NPT

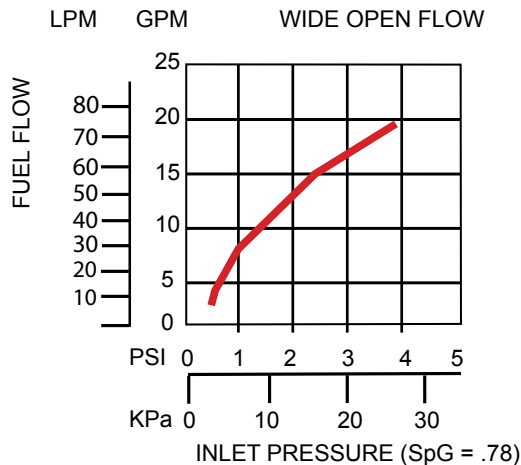

WARNING: Cancer and Reproductive Harm - www.P65Warnings.ca.gov

E25 Safe-T-Breaks®

All Husky® Safe-T-Breaks® stop the flow of fuel on both sides of the separation.

Dimensions and System Options

Guards

MODEL NO.	DESCRIPTION
003096	006360 Scuff Guard

Accessories, Testing and Maintenance

MODEL NO.	DESCRIPTION
007000	Safe-T-Break® Drain Cup
003813	Safe-T-Break® Demonstration Kit

Model 006360

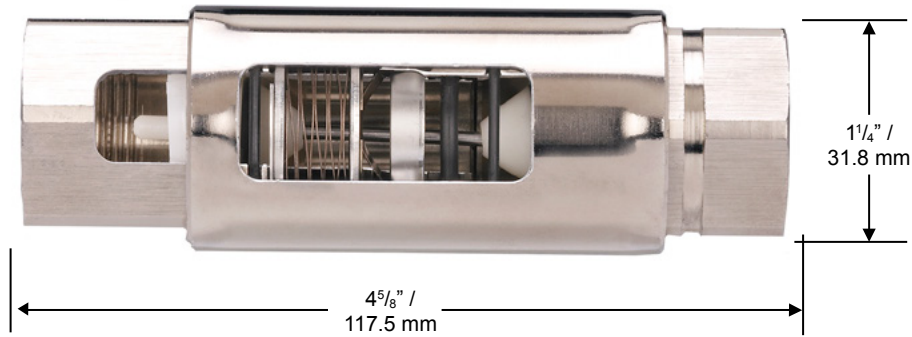

Inline **STB**

All Husky® Safe-T-Breaks® stop the flow of fuel on both sides of the separation and have passed the demanding UL test requirements on separations without leaking or failing.

- Threads directly into nozzle inlet.
- Separates at 180-337 lbs (800-1500N).
- Reconnectable.
- Stops flow on hose side of break.
- Separates at angles up to 90 degrees.
- Aluminum internal flow director - stronger than Elaflex plastic design.
- Check valve o-ring to ensure reliable fuel shut-off, not included on Elaflex.

New Inline **SAFE-T-BREAK®**

MODEL NO.	DESCRIPTION	SHIPPING WEIGHT LBS (KG)
008521A	Inline Safe-T-Break®	.45 (.20)

Construction

Body	Aluminum
Seals	Fluorocarbon
Threads	M34 x 1.5

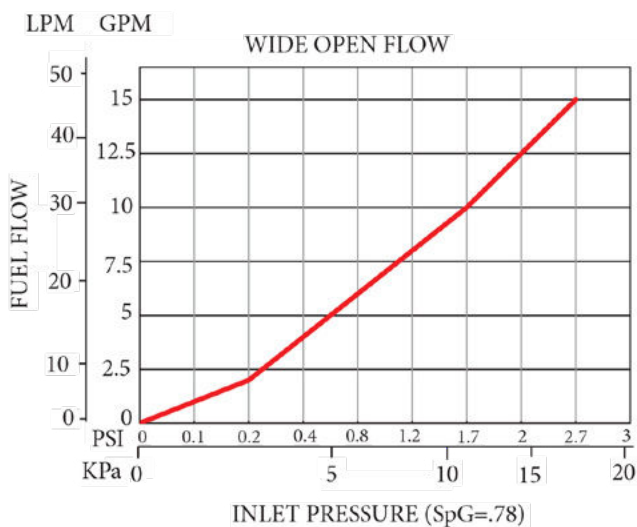

! WARNING: Cancer and Reproductive Harm - www.P65Warnings.ca.gov

Inline STB

All Husky® Safe-T-Breaks® stop the flow of fuel on both sides of the separation and have passed the demanding UL test requirements on separations without leaking or failing.

Dimensions

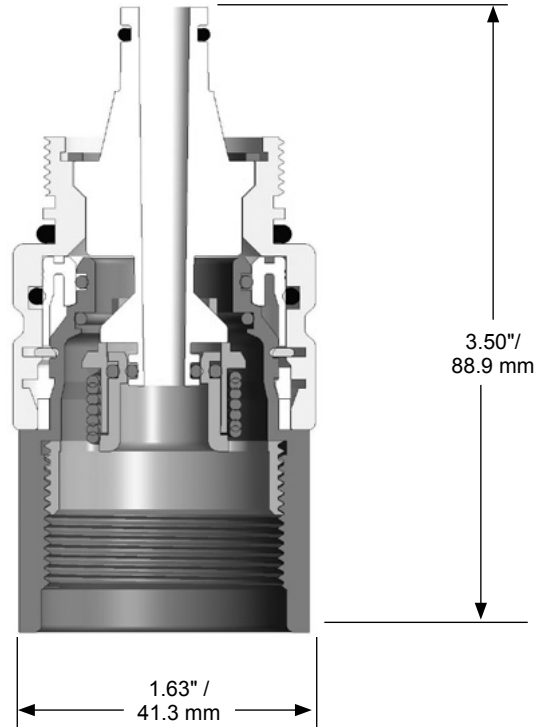

E25/E85 MAGBREAK®

All Husky® Safe-T-Breaks® stop the flow of fuel on both sides of the separation and have passed the demanding UL test requirements on separations without leaking or failing.

- High impact resistant polymer housing.
- Compatible with unleaded, diesel, and all Ethanol blends through E85
- Features same separation mechanism as Model 008330
- Lighter than competing magnetic breakaways.
- Two straight screwdrivers used to separate.
- For easier install and maintenance on other hanging hardware
- Assurance of proper reconnection using a simple “twist to lock” feature.
- Absorb line shock in excess of 450 psi at 17 gpm (31 bar at 64.3 Lpm)
- Low scuff housing.
- Line shock absorbing design.
- Stops flow on both sides of break.

G2 E25/E85 MAGBREAK®

MODEL NO.	DESCRIPTION	SHIPPING WEIGHT LBS (KG)
014647	G2 MAGBREAK® 3/4" F x 3/4" F E25/85 NPT (Separates at less than 200 pounds pull force)	1.21 (.55)

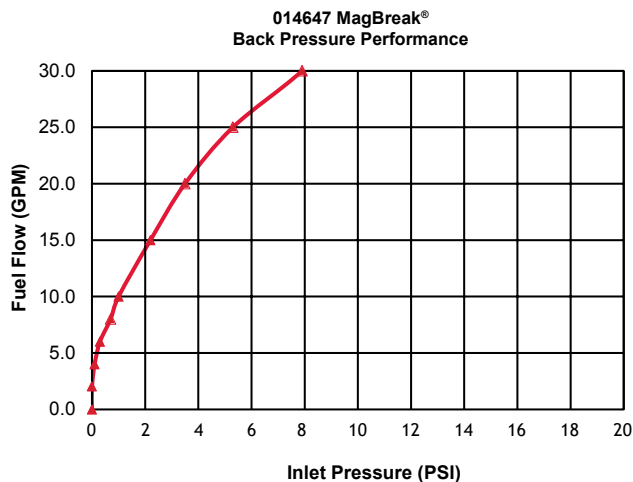

WARNING: Cancer and Reproductive Harm - www.P65Warnings.ca.gov

E25/E85 MAGBREAK®

All Husky® Safe-T-Breaks® stop the flow of fuel on both sides of the separation and have passed the demanding UL test requirements on separations without leaking or failing.

Dimensions

G2 E25/E85 Magbreak®





GENERAL FUELING PRODUCTS

Swivels/STB Combos

Standard Swivel/STB

Husky Model 006310 Swivel Safe-T-Break® combination for standard fueling applications.

- Multi-plane, full 360° spherical rotation for easy movement of nozzle.
- Swivel Sync® feature to prevent separation failure in the 90° position.
- Safe-T-Break® is reconnectable and retains UL listing after reconnecting.
- Dual check valves stops fuel in both directions.
- Separates at less than 325 lbf / 1,445.6 N which minimizes backlash force of separations, reducing damage to equipment.
- Wave spring helps reduce nuisance breaks due to water hammer.
- Dynamic seals have double o-ring construction for long life and low temperature performance.
- Compatible with Ethanol blends though E10.
- Compact and light weight for easy handling.
- Easier to reconnect when installed at the nozzle.
- Eliminates the need for a whip hose.

Swivel/Safe-T-Break® Combination

MODEL NO.	DESCRIPTION	SHIPPING WEIGHT LBS (KG)
006310	¾" NPT M x ¾" NPT F Multi-Plane Swivel Reconnectable Safe-T-Break®	.90 (.40)
007085	¾" BSP M x ¾" BSP F Multi-Plane Swivel Reconnectable Safe-t-Break®	.90 (.40)
007085A*	¾" BSP M x ¾" BSP F Multi-Plane Swivel Reconnectable Safe-t-Break® - Atex	.90 (.40)

Construction

Body	Aluminum, Zinc Alloy
Seals	Fluorosilicone, Fluorocarbon
Springs	Stainless Steel
Threads	Various

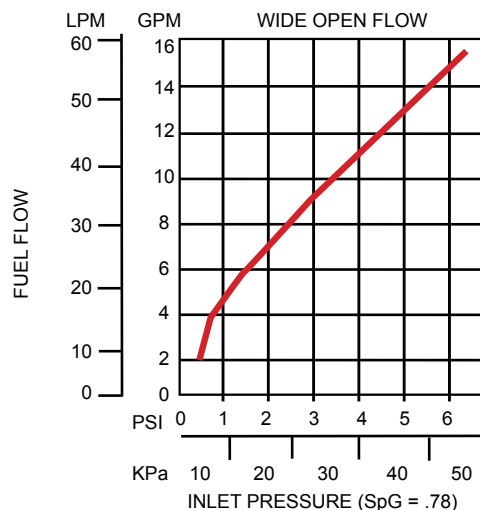

II 2 G
EN 13617-2 TYPE 1
EN 13617-4 STYLE 1



WARNING: Cancer and Reproductive Harm - www.P65Warnings.ca.gov

Standard Swivel/STB

Husky Model 006310 Swivel Safe-T-Break® combination for standard fueling applications.

Dimensions and System Options

Guards

MODEL NO.	DESCRIPTION
006534	Scuff Guard for Safe-T-Break®

Guard Color Chart

COLOR	SUFFIX	COLOR	SUFFIX	COLOR <i>CUSTOM</i>	SUFFIX
Blue	-01	Gold	-08	Amoco Blue	-07 <i>CUSTOM</i>
Red	-02	Silver	-09	Apple Green	-18 <i>CUSTOM</i>
Green	-03	BP Green	-16	Purple	-19 <i>CUSTOM</i>
Black	-04	M Blue	-25	Pink	-20 <i>CUSTOM</i>
Yellow	-05	Orange	-39	BPS Green	-22 <i>CUSTOM</i>
White	-06				

Scuff Guards are to be ordered with the corresponding guard color option added to the model number.
 Example: If BLUE guards are desired, add guard color option -01 to the model number (159504-01).
 For custom colors, a minimum order of 4,000 guards will be required.

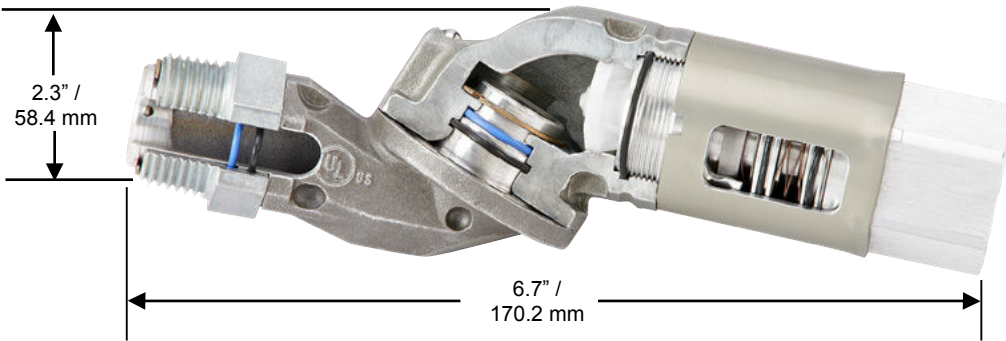

High Volume Swivel/STB

Husky® Model 005969 Swivel Safe-T-Break® Combination for truck and high volume fueling.

- Multi-plane, full 360° spherical rotation for easy movement of nozzle.
- Swivel Sync® feature to prevent separation failure in the 90° position.
- High strength step shoulder bearing diameters and impact absorbing stops.
- Dynamic seals have double o-ring construction for long life and low temperature performance.
- Separates at less than 325 lbf / 1,445.6 N which minimizes backlash force of separations, reducing damage to equipment.
- Safe-T-Break® is reconnectable and retains UL listing after reconnecting.
- Dual check valves stop fuel in both directions.
- Internal pressure balancing chamber prevents “line shock” nuisance separations.
- Compatible with Ethanol blends through E10.
- Compact and light weight for easy handling.
- Easier to reconnect when installed at the nozzle.
- Eliminates the need for a whip hose.

Swivel/Safe-T-Break® Combination

MODEL NO.	DESCRIPTION	SHIPPING WEIGHT LBS (KG)
005969	1" NPT M x 1" NPT F Multi-Plane Swivel Reconnectable Safe-T-Break®	1.5 (0.7)
008015	1" BSP M x 1" BSP F Multi-Plane Swivel Reconnectable Safe-T-Break®	1.5 (0.7)
008015A*	1" BSP M x 1" BSP F Multi-Plane Swivel Reconnectable Safe-T-Break® - Atex	1.5 (0.7)
008985	1" BSP M x 1" BSP M Multi-Plane Swivel Reconnectable Safe-T-Break®	1.5 (0.7)
008985A*	1" BSP M x 1" BSP M Multi-Plane Swivel Reconnectable Safe-T-Break® - Atex	1.5 (0.7)

Construction

Body	Aluminum, Zinc Alloy
Seals	Fluorocarbon
Springs	Stainless Steel
Threads	Various

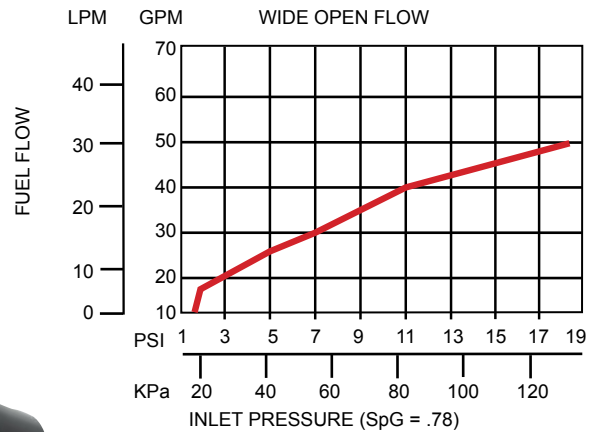

* II 2 G
EN 13617-2 TYPE 1
EN 13617-4 STYLE 1

WARNING: Cancer and Reproductive Harm - www.P65Warnings.ca.gov

High Volume Swivel/STB

Husky® Model 005969 Swivel Safe-T-Break® Combination for truck and high volume fueling.

Dimensions and System Options

Guards

MODEL NO.	DESCRIPTION
006534	Scuff Guard for Safe-T-Break®

Accessories, Testing and Maintenance

MODEL NO.	DESCRIPTION
007000	Safe-T-Break® Drain Cup

Guard Color Chart

COLOR	SUFFIX	COLOR	SUFFIX	COLOR <i>CUSTOM</i>	SUFFIX
Blue	-01	Gold	-08	Amoco Blue	-07 <i>CUSTOM</i>
Red	-02	Silver	-09	Apple Green	-18 <i>CUSTOM</i>
Green	-03	BP Green	-16	Purple	-19 <i>CUSTOM</i>
Black	-04	M Blue	-25	Pink	-20 <i>CUSTOM</i>
Yellow	-05	Orange	-39	BPS Green	-22 <i>CUSTOM</i>
White	-06				

Scuff Guards are to be ordered with the corresponding guard color option added to the model number. Example: If BLUE guards are desired, add guard color option -01 to the model number (159504-01). For custom colors, a minimum order of 4,000 guards will be required.

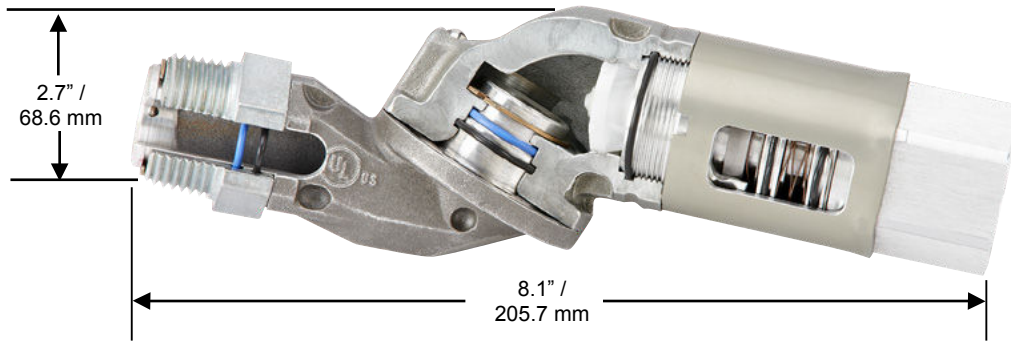

Inline Combo Swivel/STB

Inline combo

- Single Plane 360° Rotation
- Unique to Husky® products, the steel ball bearing design provides easier joint movement during high pressure applications.
- Safe-T-Break® is service reconnectable
- Check valve to stop flow of fuel on hose side
- Check valve O-ring to ensure reliable fuel shut-off
- Separates between 180 lbs. and 337 lbs.
- Separates at angles up to 90°
- Compact and easy to handle
- Fuel/Diesel or DEF versions available



Inline Combo

MODEL NO.	DESCRIPTION	SHIPPING WEIGHT LBS (KG)
012828	3/4" BSP M x 3/4" BSP F, DEF	.90 (.40)
012831	3/4" BSP M x 3/4" NPT F, DEF	.90 (.40)
012887	3/4" BSP M x 1" BSP F, DEF	.90 (.40)
012890	3/4" BSP M x 1" BSP M, DEF	.80 (.36)
013185	M34 M x 1" BSP M, DEF	.80 (.36)
013530A*	1" BSP M x 1" BSP M, Standard Fuel, Atex	.90 (.40)
013827A*	3/4" BSP M x 3/4" BSP M Standard Fuel, Atex	.80 (.36)
014438A*	1" BSP M x 1" BSP M, DEF, Atex	.90 (.40)

Construction

Body	Body: Anodized aluminum / Alodined Aluminum
Seals	Fluorocarbon
Nuts	DEF - Stainless steel, Fuel - electroless nickel-plated steel
Threads	BSP, NPT and M34

1" INLET

WIDE OPEN FLOW

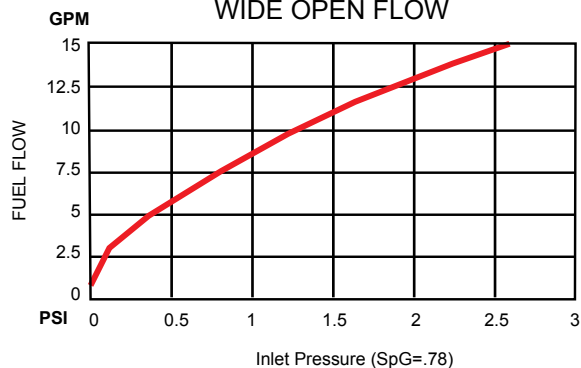

3/4" INLET

WIDE OPEN FLOW

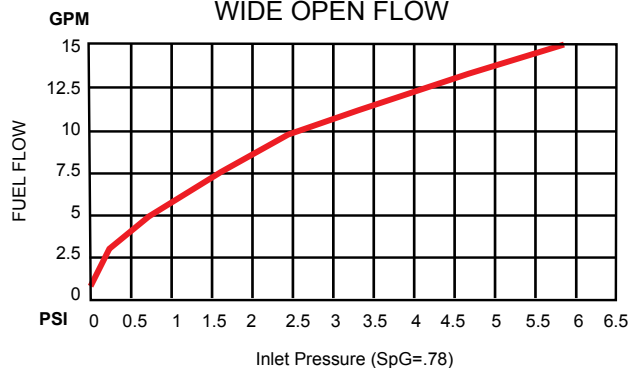

II 1 G
EN13617
Type 2

⚠ WARNING: Cancer and Reproductive Harm - www.P65Warnings.ca.gov

Inline Combo Swivel/STB

Inline combo

Dimensions and System Options

Guards

MODEL NO.	DESCRIPTION
016939	Scuff Guard for Safe-T-Break®

Color Chart

COLOR	SUFFIX	COLOR	SUFFIX
Blue	-01	White	-06
Red	-02	Gold	-08
Green	-03	Silver	-09
Black	-04	BP Green	-16
Yellow	-05	Pink	-20

**Safe-T-Breaks® and Safe-T-Break® Scuff Guards are to be ordered with the corresponding guard color option added to the model number.
 Example: If BLUE guards are desired, add guard color option -01 to the model number (004034-01).
 For custom colors, a minimum order of 4,000 guards will be required.





GENERAL FUELING PRODUCTS

Guards

Husky® Guards

For nozzles and Safe-T-Breaks®



Nozzle Guards

- Nozzle Guards, Nozzle Reguards, Waffle Splash Guards and Safe-T-Break® Guards are to be ordered with the corresponding color option added to the model number.
- Custom colors are available for all Nozzle Guards, Nozzle Reguards, Waffle Splash Guards and Safe-T-Break® Guards.
- The Safety / Warning logo will be printed on all Nozzle Guards and Nozzle Reguards.
- The E85 logo is available on all Nozzle Guards, Nozzle Reguards and Safe-T-Break® Guards upon request.
- A customized logo can be printed on any Nozzle Guard or Nozzle Reguard upon request

Safe-T-Break® Guards

- Protects dispenser from damage caused by the Safe-T-Break® and whip hose.
- Protects the Safe-T-Break® against corrosion due to environmental exposure.
- Enhanced protection of the Safe-T-Break® during separations.
- Provides a clean / more streamline appearance.
- Available in multiple colors to coordinate with the nozzle guards.
- Available with E85 logo.

Easy-On Guard Package

MODEL NO.	DESCRIPTION
003440	X, XS®, XFS Nozzles (includes 003795 Mate Nozzle Guard and 012117 Fluted Handle Cover)
011597	V34 International Nozzles (includes 014526 Mate Nozzle Guard and 010089 Handle Cover)
014524	X, XS®, XFS International Nozzles (includes 014530 Mate Nozzle Guard and 007361 Handle Cover)

Full Grip Nozzle Guards

MODEL NO.	DESCRIPTION
000554	1A, 1GS, 1HS Nozzles
004145	X, XS®, XFS Nozzles
004740	VIII, VIIS Nozzles
005170	V3 Nozzles
006483	Safe-T-Squeeze® Nozzles
006951	V34 Nozzles

Full Grip Nozzle Reguards (includes zip tie)

MODEL NO.	DESCRIPTION
001804	1A, 1GS, 1HS Nozzles
001806	X, XS®, XFS Nozzles
005516	VIII, VIIS Nozzles
004231	V34 Nozzles
005169	V3 Nozzles

Nozzle Guard Packages

MODEL NO.	DESCRIPTION
000099	1A, 1HS Nozzle Protection Package (includes 000554 Full Grip Nozzle Guard and 001808 Waffle Splash Guard)
001506	X, XS® Nozzle Protection Package (includes 004145 Full Grip Nozzle Guard and 001808 Waffle Splash Guard)
001809	X, XS® Nozzle Reguard Package (includes 001806 Full Grip Reguard, Zip Tie and 001808 Waffle Splash Guard)
001811	1A, 1HS Nozzle Reguard Package (includes 001804 Full Grip Reguard, Zip Tie and 001808 Waffle Splash Guard)

Waffle Splash Guards

MODEL NO.	DESCRIPTION
001807	Waffle Splash Guard (small hole)
001808	X, XS®, 1A, 1HS, VIII, VIIS Nozzles
006955	V3 Nozzles

Safe-T-Break® Guards

MODEL NO.	DESCRIPTION
003096	003360, 006130, and 005230 Safe-T-Breaks®
003098	002276, 004034, 005134, 006210, 006301, and 006560 Safe-T-Breaks®
003990	003360VR Safe-T-Break®
006534	006310 Swivel Safe-T-Break® Combo
006503	2 piece Safe-T-Break® Dispenser Guard
006570	2 piece Safe-T-Break® Dispenser Guard with E85 logo

Mate Nozzle Guards

MODEL NO.	DESCRIPTION
000226	1A, 1GS, 1HS, DEF Nozzles
003795	X, XS®, XFS Nozzles
007295	1A, 1GS, 1HS, DEF Handle Cover
007361	X, XS®, XFS, DEF X, PHG Handle Cover
010089	V34, PHG Handle Cover
012117	X, XS®, XFS Fluted Handle Cover
014526	V34 International Nozzles
014530	X, XS®, XFS International Nozzles
015257	1A, 1GS, 1HS, DEF International Nozzles



WARNING: Cancer and Reproductive Harm - www.P65Warnings.ca.gov

Husky® Guards

For nozzles and Safe-T-Breaks®



Guard Color Chart

COLOR	SUFFIX	COLOR	SUFFIX	COLOR <i>CUSTOM</i>	SUFFIX
Blue	-01	Gold	-08	Amoco Blue	-07 <i>CUSTOM</i>
Red	-02	Silver	-09	Apple Green	-18 <i>CUSTOM</i>
Green	-03	BP Green	-16	Purple	-19 <i>CUSTOM</i>
Black	-04	M Blue	-21	Pink	-20 <i>CUSTOM</i>
Yellow	-05	Orange	-39	BPS Green	-22 <i>CUSTOM</i>
White	-06				

Scuff Guards are to be ordered with the corresponding guard color option added to the model number.
 Example: If BLUE guards are desired, add guard color option -01 to the model number (159504-01).
 For custom colors, a minimum order of 4,000 guards will be required.



GENERAL FUELING PRODUCTS

Spouts

X, XS[®] Spouts

Spout assemblies

- Stainless Steel Spout Bushing (optional on LDD)
- *Streamshaper*[®]
- Keeps spout tip round
- Reduces turbulence for straighter fuel flow and less splashback spillage



Unlead Spout Assembly



Light-Duty Diesel Spout Assembly

Unlead Spout Assemblies

MODEL NO.	DESCRIPTION	SHIPPING WEIGHT LBS (KG)
001473	X, XS [®] , 1A, 1GS Spout Assembly with Streamshaper [®]	.3 (.14)
008684	X, XS [®] , 1A, 1GS MTBE Spout Assembly with Streamshaper [®]	.3 (.14)
010432	X, XS [®] , 1A, 1GS Long Spout Assembly with Streamshaper [®]	.4 (.18)
014376	X, XS [®] , 1A, 1GS Spout Assembly without Spout Spring, with Streamshaper [®]	.4 (.18)
014420	X, XS [®] , 1A, 1GS Spout Assembly with Streamshaper [®] and Spout Ring	.4 (.18)

Light Duty Diesel Spout Assemblies

MODEL NO.	DESCRIPTION	SHIPPING WEIGHT LBS (KG)
001471	X, XS [®] , 1A, 1GS Spout Assembly with Streamshaper [®]	.4 (.18)
014378	X, XS [®] , 1A, 1GS Spout Assembly without Spout Spring, with Streamshaper [®]	.4 (.18)
014421	X, XS [®] , 1A, 1GS Spout Assembly with Streamshaper [®] and Spout Ring	.4 (.18)



 WARNING: Cancer and Reproductive Harm - www.P65Warnings.ca.gov

X, XS[®] Spouts

Spout assemblies

Dimensions

Unlead Spouts

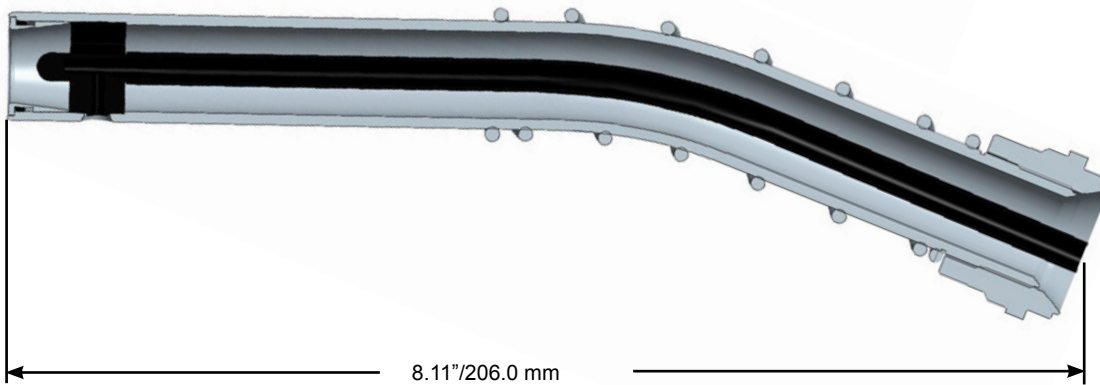
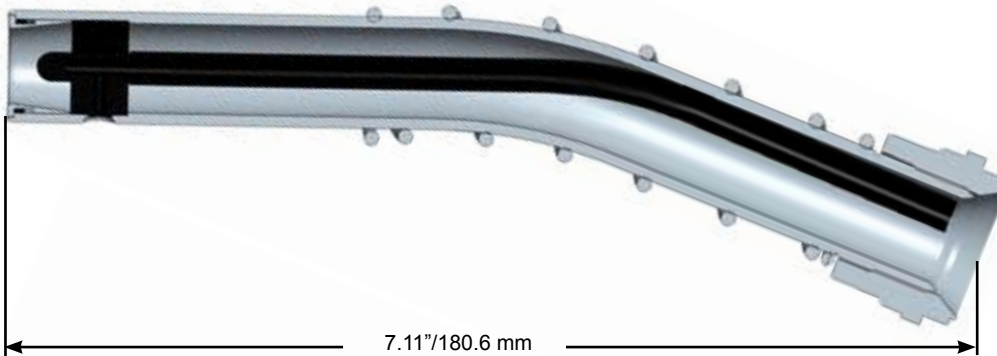

Light Duty Diesel Spout

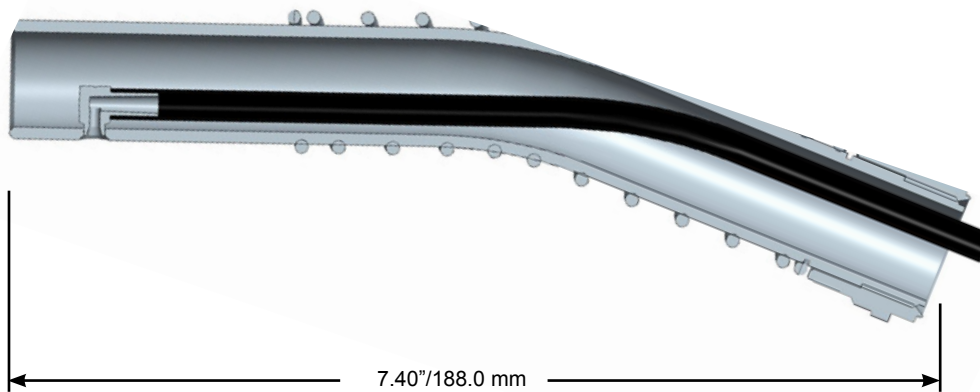

1GS Spouts

Spout assemblies

- Stainless Steel Spout Bushing (optional on LDD).
- *Streamshaper*®
- Keeps spout tip round.
- Reduces turbulence for straighter fuel flow and less splashback spillage.



Unlead Spout Assemblies

MODEL NO.	DESCRIPTION	SHIPPING WEIGHT LBS (KG)
001473	X, XS®, 1A, 1GS Spout Assembly with Streamshaper®	.3 (.14)
003356	XFS Spout Assy with Hanging Hook and Streamshaper®	.5 (.23)
008684	X, XS®, 1A, 1GS MTBE Spout Assembly with Streamshaper®	.3 (.14)
010432	X, XS®, 1A, 1GS Long Spout Assembly with Streamshaper®	.4 (.18)
014376	X, XS®, 1A, 1GS Spout Assembly without Spout Spring, with Streamshaper®	.4 (.18)
014420	X, XS®, 1A, 1GS Spout Assembly with Streamshaper® and Spout Ring	.4 (.18)

Light Duty Diesel Spout Assemblies

MODEL NO.	DESCRIPTION	SHIPPING WEIGHT LBS (KG)
001471	X, XS®, 1A, 1GS Spout Assembly with Streamshaper®	.4 (.18)
003358	XFS Spout Assembly with Hanging Hook	.6 (.27)
014378	X, XS®, 1A, 1GS Spout Assembly without Spout Spring, with Streamshaper®	.4 (.18)
014421	X, XS®, 1A, 1GS Spout Assembly with Streamshaper® and Spout Ring	.4 (.18)

High Flow/High Volume Spout Assemblies

MODEL NO.	DESCRIPTION	SHIPPING WEIGHT LBS (KG)
005215	1HS, 1GS Spout Assembly	.4 (.18)



 WARNING: Cancer and Reproductive Harm - www.P65Warnings.ca.gov

1GS Spouts

Spout assemblies

Dimensions

Unlead Spouts

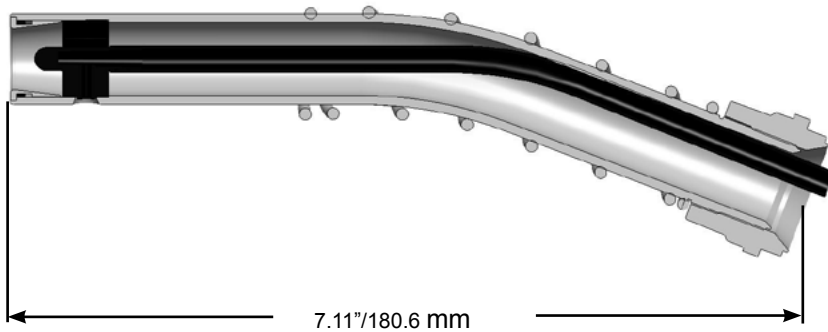

Light Duty Diesel Spout

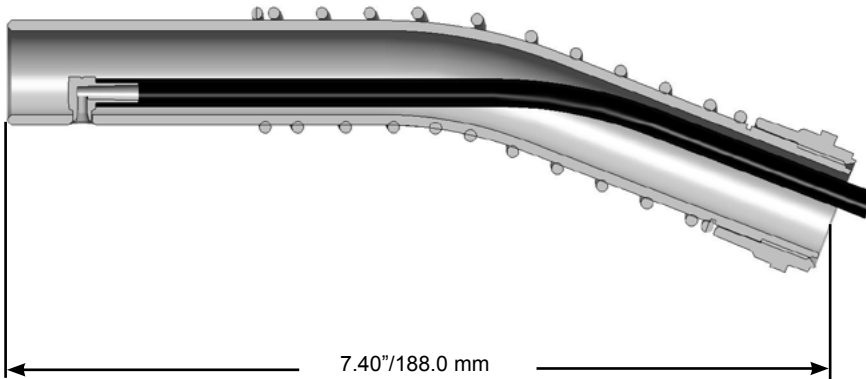

High Flow/High Volume Spout

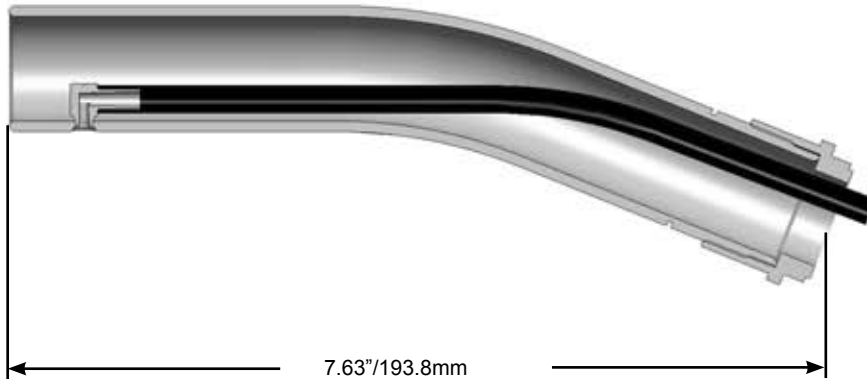

DEF Spouts

Spout assemblies

- Spout assemblies with the *StreamShaper*® reduces turbulence for straighter DEF flow and less splash back spillage.
- Spout assemblies with the Flo-Stop® device that shuts off the nozzle if it falls from the fill tank or raises above the horizontal.
- Spout assemblies with the Accufuel® safety feature prevents misfilling of DEF in the diesel tank.

Stainless Steel DEF Nozzle Spout Assemblies

MODEL NO.	DESCRIPTION	SHIPPING WEIGHT LBS (KG)
007360	with Spout Ring and Flo-Stop®	.4 (.18)
007362	with Flo-Stop®	.4 (.18)
007364	with Spout Ring and Magnetic Accufuel® Safety Feature	.4 (.18)

X DEF Nozzle Spout Assemblies

MODEL NO.	DESCRIPTION	SHIPPING WEIGHT LBS (KG)
013285	with StreamShaper®	.4 (.18)
013286	with Spout Ring and Magnetic Accufuel® Safety Feature	.4 (.18)

Polymer DEF Nozzle Spout Assemblies

MODEL NO.	DESCRIPTION	SHIPPING WEIGHT LBS (KG)
013591	with StreamShaper®	.4 (.18)
013592	with Spout Ring and StreamShaper®	.4 (.18)
013593	with Spout Ring and Magnetic Accufuel® Safety Feature	.4 (.18)



 WARNING: Cancer and Reproductive Harm - www.P65Warnings.ca.gov

DEF Spouts

Spout assemblies

Dimensions

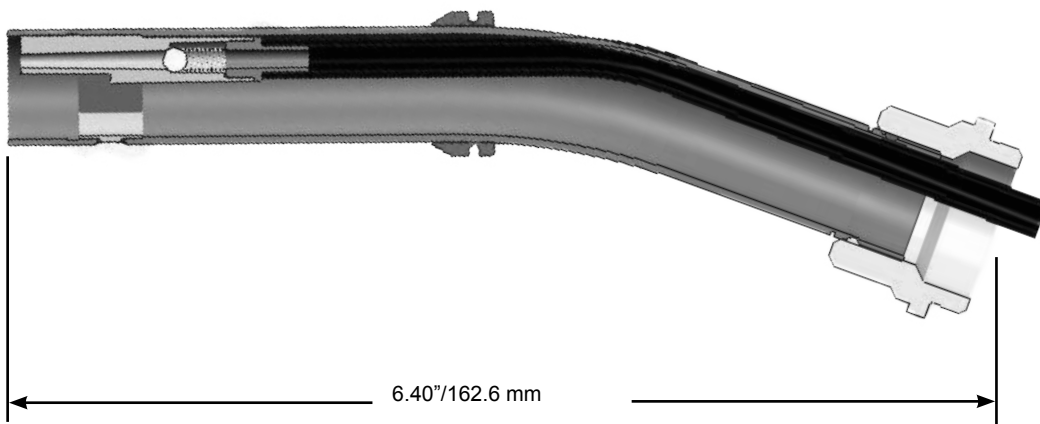
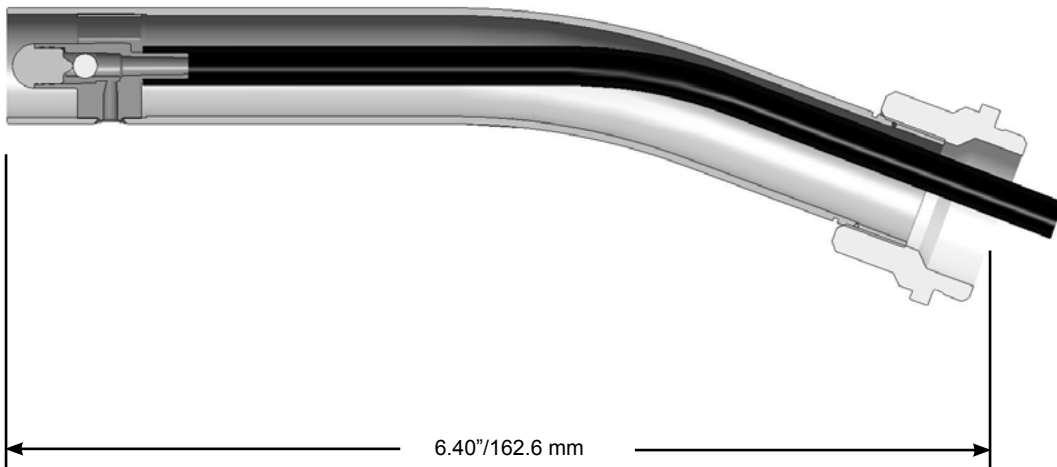
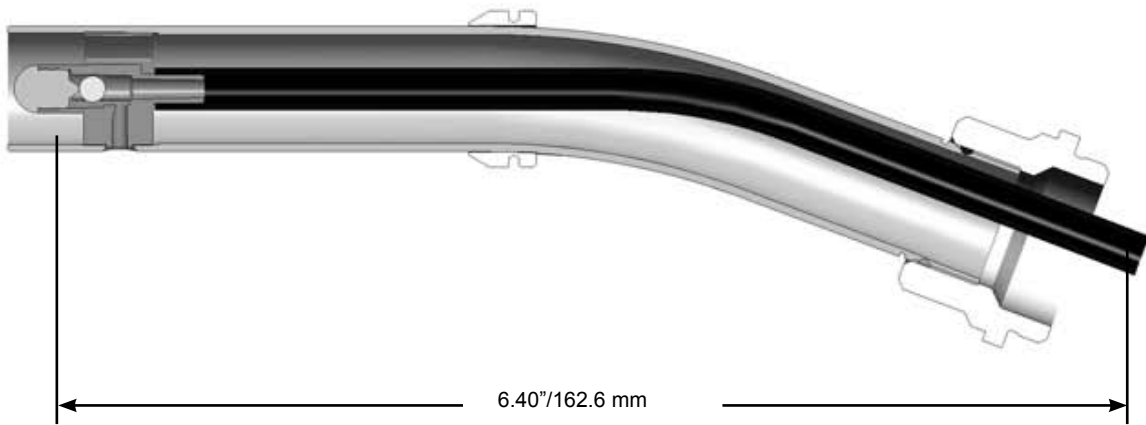

VIII, VIIS Spouts

Spout assemblies

- Aluminum Spout Bushing.
- Flow stop device.
- Reduces rounding in of spout.
- Retains spout spring.
- Shuts off flow when spout is raised above horizontal.

High Flow/High Volume Spout Assemblies

MODEL NO.	DESCRIPTION	SHIPPING WEIGHT LBS (KG)
002279	VIII, VIIS Spout Assembly with Spout Bushing	.9 (.41)
003589	VIII, VIIS Long Spout Assembly without Spout Bushing	1.0 (.45)
004889	1690 High-Volume Spout Assembly without Shear Groove (USA)	.5 (.23)
005017	VIII, VIIS Spout Assembly without Spout Bushing	.9 (.41)
005042	1691 High-Volume Spout Assembly with Shear Groove (Canada)	.5 (.23)
005215	1HS,1GS Spout Assembly	.4 (.18)
007218	VIII, VIIS Long Spout Assembly with Spout Bushing	1.0 (.45)



WARNING: Cancer and Reproductive Harm - www.P65Warnings.ca.gov

VII, VIIS Spouts

Spout assemblies

Dimensions

High Flow/High Volume Spouts

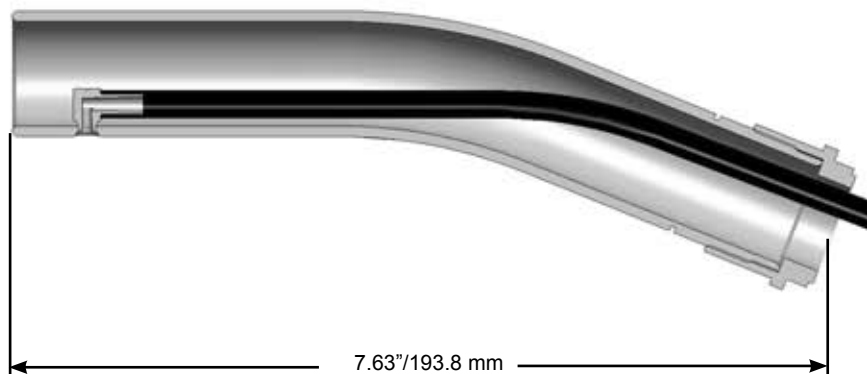
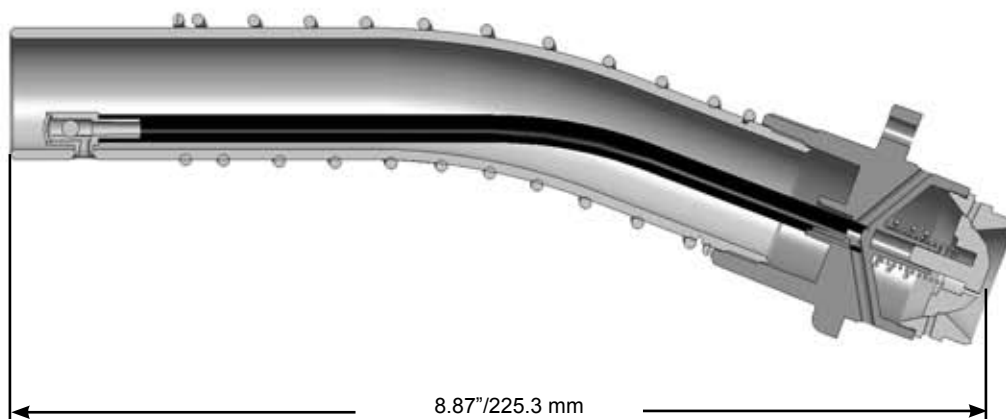
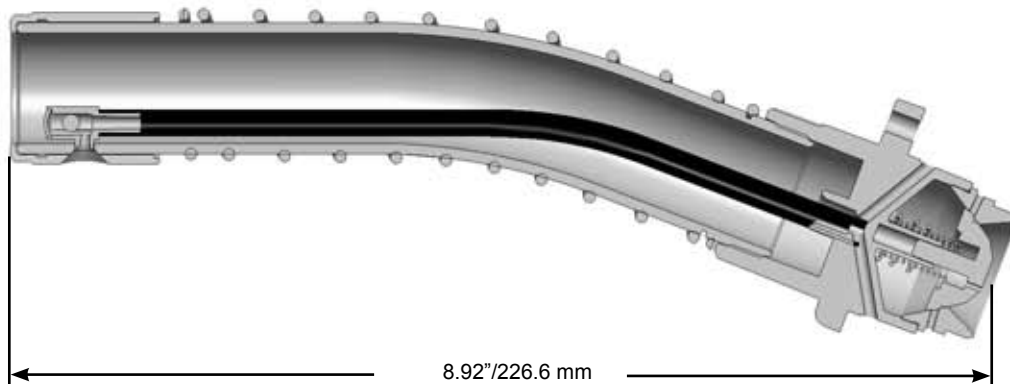

V3 & V34 Spouts

Spout assemblies

- Stainless steel spout bushing.
- *Streamshaper*® reduces turbulence for straighter fuel flow and less splash back spillage.
- Keeps spout tip round.



V3 Spout Kit



V34 Spout Kit

Vacuum Assist Vapor Recovery Unlead Spout Assemblies

MODEL NO.	DESCRIPTION	SHIPPING WEIGHT LBS (KG)
004000	V34 Vapor Splash Guard (VSG) (Includes 004039 Clamp)	.1 (.05)
004039	VSG Single Use Clamp	.1 (.05)
006289	V3 Spout Assy Kit (Includes 006389 Spout Assembly and 006955 Waffle Splash Guard)	.3 (.14)
006291	V34 Spout Assy Kit (Includes 004000 VSG and 006391 Spout Assembly)	.3 (.14)
006389	V3 Spout Assembly (without Waffle Splash Guard)	.2 (.09)
006391	V34 Spout Assembly with Streamshaper®	.3 (.14)
006656	V34-006536 VSG (Includes 004039 Clamp)	.1 (.05)
006663	V34-006536 Spout Assembly Kit (Includes 006391 Spout Assembly and 006656 VSG)	.3 (.14)
008411	V34i Spout Assembly Kit with Streamshaper® (Includes 003877 O-Ring and 006511 Set Screw)	.2 (.09)
008642	V34-006200 Coaxial Spout Assembly Kit (Includes 009968 Spout Assembly and 004000 VSG)	.3 (.14)
009968	V34-006200 Coaxial Spout Assembly	.2 (.09)

Vacuum Assist Vapor Recovery Light Duty Diesel Spout Assemblies

MODEL NO.	DESCRIPTION	SHIPPING WEIGHT LBS (KG)
006261	V34C Spout Assembly Kit (Includes 004000 Vsg)	.4 (.18)
006361	V34 Spout Assembly Kit (Includes 004039 Clamp)	.3 (.14)



 WARNING: Cancer and Reproductive Harm - www.P65Warnings.ca.gov

V3 & V34 Spouts

Spout assemblies

Dimensions

Vacuum Assist Vapor Recovery

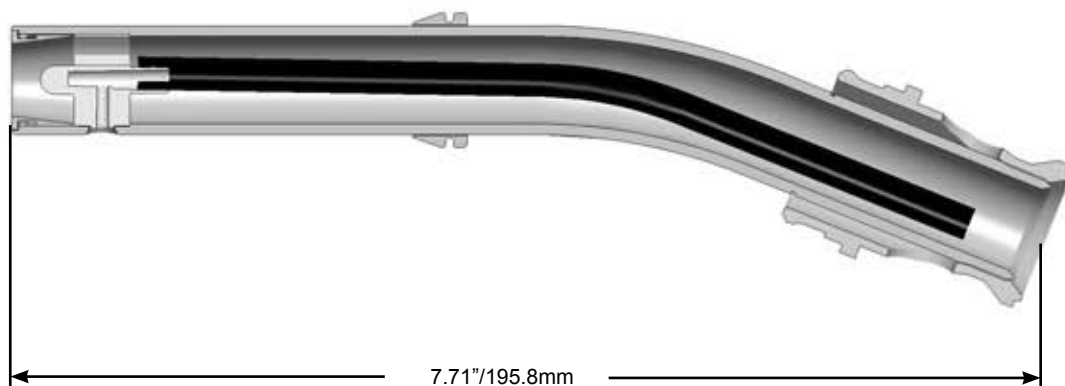

E85 Spouts

Spout assemblies

- Nickel plated aluminum spout.
- *Streamshaper*®
- Stainless Steel Spout Bushing.
- E85 compatible.
- Keeps spout tip round.
- Reduces turbulence for straighter fuel flow and less splashback spillage.

Ethanol Spout Assemblies

MODEL NO.	DESCRIPTION	SHIPPING WEIGHT LBS (KG)
006207	X, XS® E85 Spout Assembly with Streamshaper®	.4 (.18)



WARNING: Cancer and Reproductive Harm - www.P65Warnings.ca.gov

E85 Spouts

Spout assemblies

Dimensions

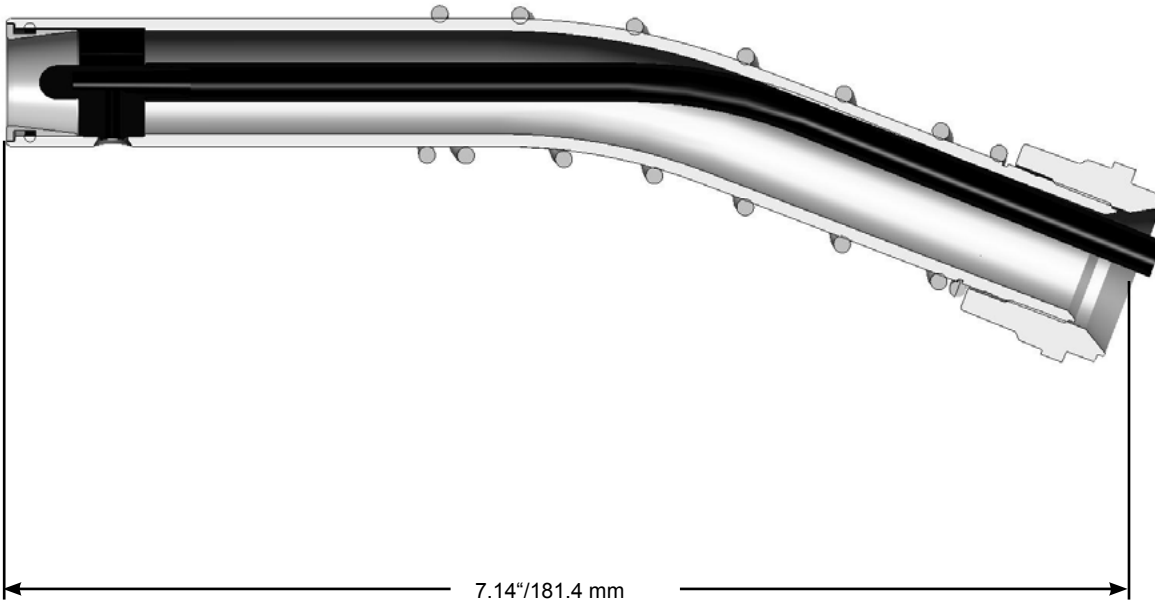



Husky[®]

GENERAL FUELING PRODUCTS

PV Vents

Model 008060 has three (3) separate valves that address pressure/vacuum conditions in underground storage tanks (UST) and above ground storage tanks (AST).

- Husky pressure / vacuum (P/V) vents incorporate three (3) separate valves to control over-pressure and vacuum conditions that arise in storage tanks. The three (3) valve system provides the necessary protection and durability needed in UST and AST vent caps.
- The vacuum valve is diaphragm operated and provides ten (10) times more sealing force than gravity devices. It constantly opens at 6" - 8" of water column (WC) / 2 - 2.5 KPa vacuum.
- The first over-pressure valve is diaphragm operated, giving ten (10) times more sealing force than gravity devices. It opens at 8" - 12" WC / .75 - 1.5 KPa pressure.
- The safety over-pressure valve is designed to handle high pressure / high flow conditions. This valve will vent up to 7900 SCFH at 2 psi / .14 bar.
- Threaded vent cap that is easily installed by using the cast-on hex nut which allows tightening without having to go between vent pipes.
- Not for use in California / EVR applications.
- Constructed from materials 100% compatible with B0-B20 and E0-E85.

Pressure/Vacuum Vents

MODEL NO.	DESCRIPTION	SHIPPING WEIGHT LBS (KG)
008060	2" / 51 mm Thread-On Pressure / Vacuum Vent Cap	1.2 (.54)

Construction

Body	Aluminum
Screen	40 Mesh Stainless Steel
Set Screws	Stainless Steel
Deflector	Aluminum



This component was tested to and met the following criteria:

PRES. 8-12 IN. W.C.

VAC. 6-8 IN. W.C.

.05 CFH @ +2 IN. W.C.

.21 CFH @ -4 IN. W.C.



WARNING: Cancer and Reproductive Harm - www.P65Warnings.ca.gov

PV Vents

Model 008060 has three (3) separate valves that address pressure/vacuum conditions in underground storage tanks (UST) and above ground storage tanks (AST).

Dimensions and System Options

Adapter

MODEL NO.	DESCRIPTION
005041	3 in / 76 mm Thread to 2 in / 51 mm Thread Pipe Adapter

Testing Equipment

MODEL NO.	DESCRIPTION
005426	Pressure / Vacuum Vent Test Adapter

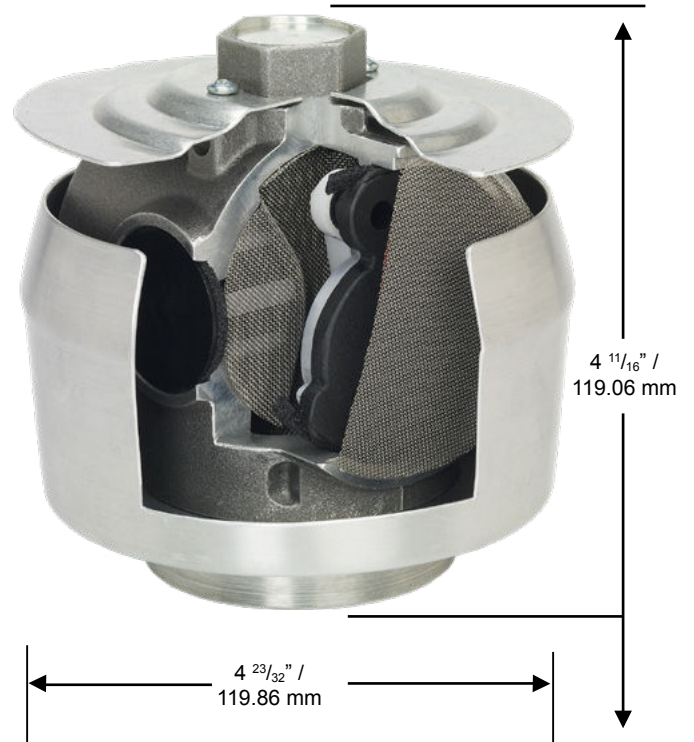

Model 008060 has three (3) separate valves that address pressure/vacuum conditions in underground storage tanks (UST) and above ground storage tanks (AST).

Model 004620 and 004885

- The three (3) valve system provides the necessary protection and durability needed in UST and AST vent caps.
- The vacuum valve is diaphragm operated and provides ten (10) times more sealing force than gravity devices. It consistently opens at 6" - 10" of water column (WC) / 1.5 - 2.5 KPa vacuum.
- The first over-pressure valve is diaphragm operated, giving ten (10) times more sealing force than gravity devices. It opens at 2.5" - 6" WC / .63 - 1.5 KPa pressure.
- Not for use in California / EVR applications.
- Model 004885 is certified to less than 1/3 of the CARB EVR Standard CP-201 which allows installation of three (3) P/V Vents maximum. This reduces installation time by not having to manifold the vent pipes together.
- Model 004885 is a threaded vent cap that is easily installed by using the caston hex nut which allows tightening without having to go between vent pipes.
- Model 004620 is a slip-on vent cap with a main pliable seal that seals to the vent stack and provides leakproof protection because the seal is at the end of the vent stack, not on the threads.

- Model 004620 uses four (4) stainless steel set screws to grip the vent stack preventing any loosening of the seal.
- Constructed from materials 100% compatible with B0-B20 and E0-E85.

Model 005885*

- Has an internal screen to protect the pressure plate in the event of a bad bulk drop.
- The safety over-pressure valve is designed to handle high pressure / high flow conditions. This valve will vent up to 7900 SCFH at 2 psi / .14 bar.
- Certified to less than 1/3 of the CARB EVR Standard CP-201 which allows installation of three (3) P/V vents maximum. This reduces installation time by not having to manifold the vent pipes together.
- Has a threaded vent cap that is easily installed by using the cast-on hex nut. This also allows tightening without having to go between vent pipes.
- Constructed from materials 100% compatible with B0-B20 and E0-E85.

Pressure/Vacuum Vents

MODEL NO.	DESCRIPTION	SHIPPING WEIGHT LBS (KG)
004620	2 in / 51 mm Slip-On Pressure / Vacuum Vent Cap	1.2 (.54)
004885	2 in / 51 mm Thread-On Pressure / Vacuum Vent Cap	1.2 (.54)
005885*	2 in / 51 mm Thread-On Pressure / Vacuum Vent Cap with internal screen	1.2 (.54)

Construction

Body	Aluminum
Screen	40 Mesh Stainless Steel
Internal Screen	40 Mesh Stainless Steel (005885 only)
Set Screws	Stainless Steel
Deflector	Aluminum



This component was tested to and met the following criteria:

PRES. 2.5-6 IN. W.C.
VAC. 6-10 IN. W.C.
.05 CFH @ +2 IN. W.C.
.21 CFH @ -4 IN. W.C.



CALIFORNIA AIR RESOURCES BOARD

PV Vents

Model 008060 has three (3) separate valves that address pressure/vacuum conditions in underground storage tanks (UST) and above ground storage tanks (AST).

Dimensions and System Options

Adapter

MODEL NO.	DESCRIPTION
005041	3 in / 76 mm Thread to 2 in / 51 mm Thread Pipe Adapter

Testing Equipment

MODEL NO.	DESCRIPTION
005426	Pressure / Vacuum Vent Test Adapter

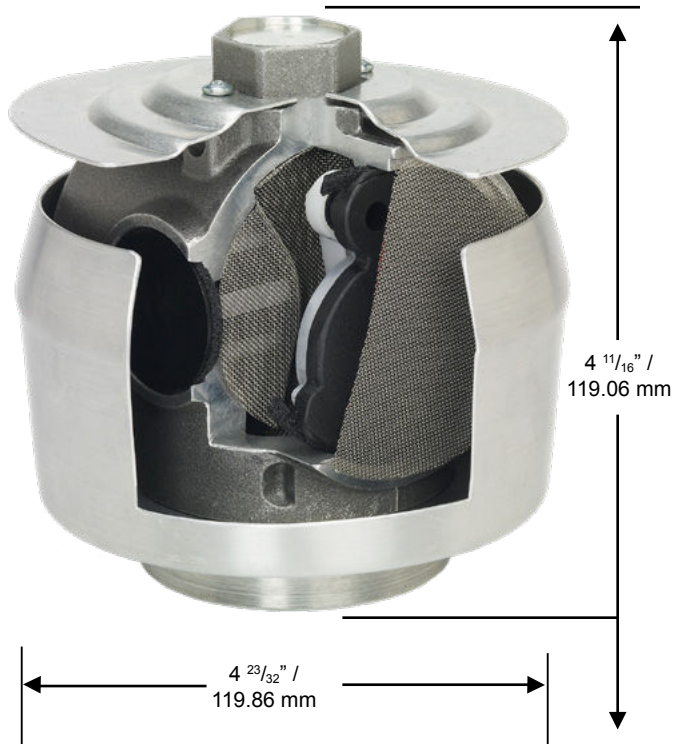



Testing & Maintenance

Nozzle Service Kit

For Conventional, Balance, or Vacuum Assist Systems

- Nozzle Service Device (NSD) can be used with all brands / styles of retail nozzles.
- NSD provides easier removal and installation of nozzles - keeps nozzles off the ground.
- Safe-T-Break® Drain Cup can be used with all brands of breakaways - even non-reconnectable versions.
- Safe-T-Break® Drain Cup allows for pressure relief making reconnecting easier.
- Fuel Filter Cup can be used on all brands / styles of automotive and diesel dispenser fuel filters.
- Provides safe collection of fuel when replacing nozzles, Safe-T-Breaks® and fuel filters.
- Allows product maintenance without getting fuel directly on hands / skin.
- NSD, Safe-T-Break® Drain Cup, Fuel Filter Cup, wrench and pliers all fit inside the service pail for easy transportation.

Nozzle Service Kit

MODEL NO.	DESCRIPTION	SHIPPING WEIGHT LBS (KG)
007089	Nozzle Service Kit (includes part 006662 NSD, 007000 Safe-T-Break® Drain Cup, 007004, Fuel Filter Cup, 007086 Service Pail, 007088 NSD Pliers, 007332 Shear Valve Wrench and 007098 Fuel Filter Tool)	9.5 (4.3)

Basic Nozzle Service Kit

MODEL NO.	DESCRIPTION	SHIPPING WEIGHT LBS (KG)
007262	Basic Nozzle Service Kit (includes part 006662 NSD, 007000 Safe-T-Break® Drain Cup, 007004, Fuel Filter Cup and 007086 Service Pail)	9.0 (4.0)

Deluxe Nozzle Service Kit

MODEL NO.	DESCRIPTION	SHIPPING WEIGHT LBS (KG)
007263	Deluxe Nozzle Service Kit (includes part 006662 NSD, 007000 Safe-T-Break® Drain Cup, 007004, Fuel Filter Cup, 007086 Service Pail, 007332 Shear Valve Wrench, 007348 Deluxe Service Pliers and 007349 Deluxe Fuel Filter Pliers)	9.5 (4.3)

Construction

Service Pail	Steel
Nozzle Service Device (NSD)	Polypropylene
Safe-T-Break® Drain Cup	Polypropylene
Fuel Filter Cup	Plastisol



WARNING: Cancer and Reproductive Harm - www.P65Warnings.ca.gov

Nozzle Service Kit

For Conventional, Balance, or Vacuum Assist Systems

Dimensions and System Options

Nozzle Service Kit Parts

MODEL NO.	DESCRIPTION
006662	Nozzle Service Device (NSD)
007000	Safe-T-Break® Drain Cup
007004*	Fuel Filter Cup
007086	Service Pail
007088	NSD 12" Pliers
007098	Fuel Filter Tool (Wrench)
007099	Fuel Filter Service Kit (includes part 007004 Fuel Filter Cup and 007098 Fuel Filter Tool)
007332	Shear Valve Wrench
007348	Deluxe Service Pliers
007349	Deluxe Fuel Filter Pliers
007350	Deluxe Service Tool Kit (includes 007332 Shear Valve Wrench, 007348 Service Pliers, and 007349 Fuel Filter Pliers)
008071	Fuel Filter Cap with 5" Base



Part No. 007086



Part No. 007000



Part No. 007004

Guard Color Chart

COLOR	SUFFIX	COLOR	SUFFIX	COLOR <i>CUSTOM</i>	SUFFIX
Blue	-01	Gold	-08	Amoco Blue	-07 <i>CUSTOM</i>
Red	-02	Silver	-09	Apple Green	-18 <i>CUSTOM</i>
Green	-03	BP Green	-16	Purple	-19 <i>CUSTOM</i>
Black	-04	M Blue	-21	Pink	-20 <i>CUSTOM</i>
Yellow	-05	Orange	-39	BPS Green	-22 <i>CUSTOM</i>
White	-06				

Scuff Guards are to be ordered with the corresponding guard color option added to the model number. Example: If BLUE guards are desired, add guard color option -01 to the model number (159504-01). For custom colors, a minimum order of 4,000 guards will be required.



Part No. 006662

HCA Hose Conversion Adaptor

For Conventional, Balance, or Vacuum Assist Systems

- Easy conversion of vapor recovery dispenser manifold to accept conventional hose configurations.

Specifications

- 1 piece machined aluminum fittings
- Fluorocarbon o-rings.

Advantages

- Simple installation



 WARNING: Cancer and Reproductive Harm - www.P65Warnings.ca.gov

HCA Hose Conversion Adaptor

For Conventional, Balance, or Vacuum Assist Systems

Dimensions and System Options

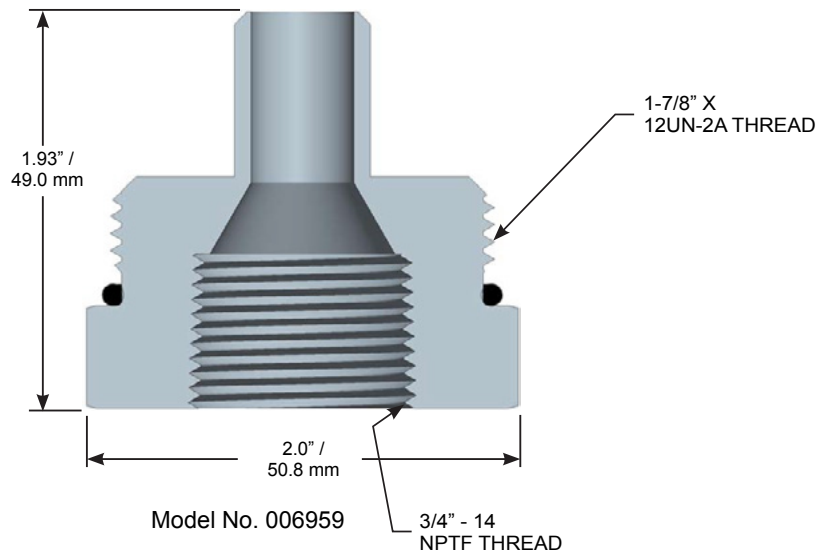
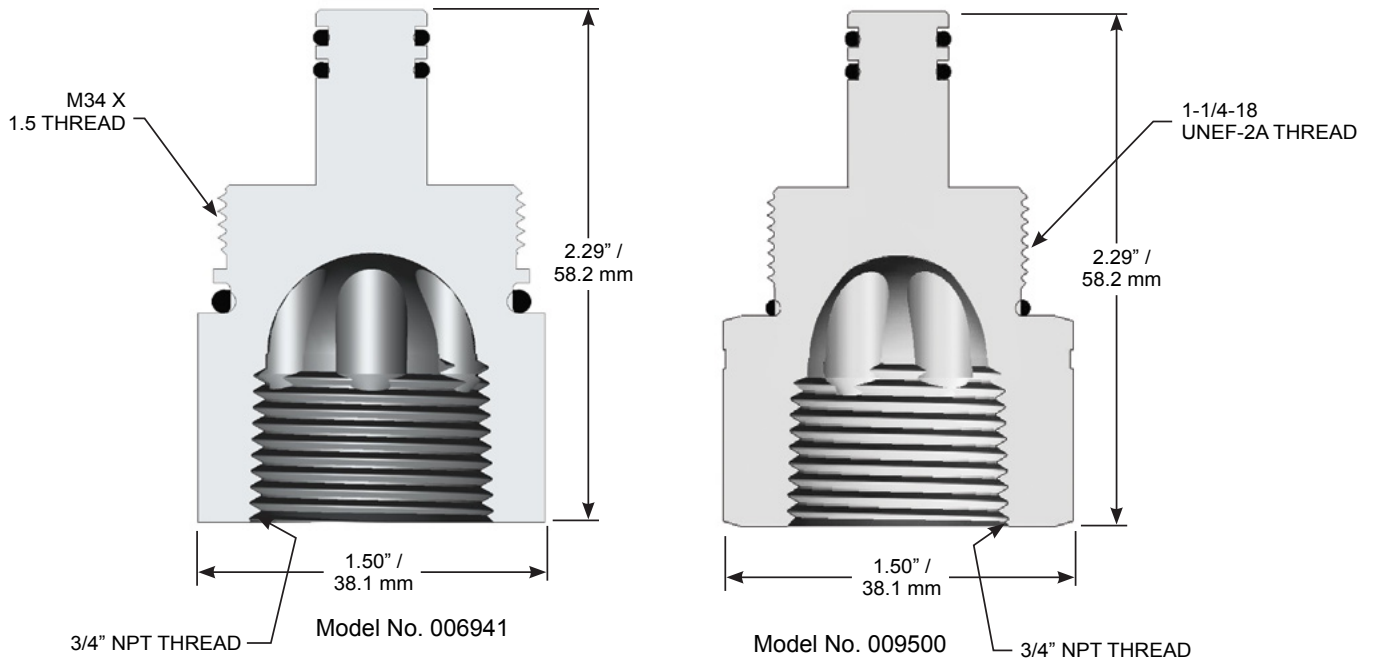

Mobile Fill Neck Device

For Conventional, Balance, or Vacuum Assist Systems

- Optimized for assessing nozzle performance by simulating a real-time tank fueling environment
- Equipped with a ball valve for easy drainage and cleanup
- Engineered to have a robust design that ensures longevity
- Folds into a compact size for easy transport and storage
- Built with the leading fill neck in the industry
- Anodized to prevent corrosion
- Unique design aids service technicians with diagnosis of damaged or worn nozzles in the field

Mobile Fill Neck

MODEL NO.	DESCRIPTION	SHIPPING WEIGHT LBS (KG)
014381	Unleaded Mobile Fill Neck Device	

Construction

Anodized Aluminum, Stainless Steel, and Brass



**Bucket and hanging hardware not included*



 WARNING: Cancer and Reproductive Harm - www.P65Warnings.ca.gov

Mobile Fill Neck Device

For Conventional, Balance, or Vacuum Assist Systems

Dimensions and System Options

Mobile Fill Neck Device Accessories

MODEL NO.	DESCRIPTION
006662	Nozzle Service Device (NSD)
007000	Safe-T-Break® Drain Cup
007004*	Fuel Filter Cup
007086	Service Pail
007088	NSD 12" Pliers
007089	Nozzle Service Kit (includes part 006662 NSD, 007000 Safe-T-Break® Drain Cup, 007004, Fuel Filter Cup, 007086 Service Pail, 007088 NSD Pliers, 007332 Shear Valve Wrench and 007098 Fuel Filter Tool)
007098	Fuel Filter Tool (Wrench)
007099	Fuel Filter Service Kit (includes part 007004 Fuel Filter Cup and 007098 Fuel Filter Tool)
007262	Basic Nozzle Service Kit (includes part 006662 NSD, 007000 Safe-T-Break® Drain Cup, 007004 Fuel Filter Cup and 007086 Service Pail)
007263	Deluxe Nozzle Service Kit (includes part 006662 NSD, 007000 Safe-T-Break® Drain Cup, 007004 Fuel Filter Cup, 007086 Service Pail, 007332 Shear Valve Wrench, 007348 Deluxe Service Pliers and 007349 Deluxe Fuel Filter Pliers)
007332	Shear Valve Wrench
007348	Deluxe Service Pliers
007349	Deluxe Fuel Filter Pliers
007350	Deluxe Service Tool Kit (includes 007332 Shear Valve Wrench, 007348 Service Pliers, and 007349 Fuel Filter Pliers)
008071	Fuel Filter Cup with 5" Base



Part No. 007086



Part No. 007000



Part No. 007004*



Part No. 006662

Guard Color Chart

COLOR	SUFFIX	COLOR	SUFFIX	COLOR <i>CUSTOM</i>	SUFFIX
Blue	-01	Gold	-08	Amoco Blue	-07 <i>CUSTOM</i>
Red	-02	Silver	-09	Apple Green	-18 <i>CUSTOM</i>
Green	-03	BP Green	-16	Purple	-19 <i>CUSTOM</i>
Black	-04	M Blue	-21	Pink	-20 <i>CUSTOM</i>
Yellow	-05	Orange	-39	BPS Green	-22 <i>CUSTOM</i>
White	-06				

Scuff Guards are to be ordered with the corresponding guard color option added to the model number. Example: If BLUE guards are desired, add guard color option -01 to the model number (159504-01). For custom colors, a minimum order of 4,000 guards will be required.

Full Filter & Drain Cups

Safe and Clean filter removal.

- 007004, 008071, 016506, 016664, & 016642 safely holds oils, fuel (gasoline, diesel, biofuels), brake fluid, antifreeze and other hazardous fluids.
- Pliable, non-slip plastisol material conforms for secure grip including within small, oddly shaped places.
- Allows filter maintenance without getting fuel or oil directly on the skin.
- Filter Cups can be used on all brands and styles of fuel dispenser and vehicle fuel/oil filters.
- Great for storing loose nuts, bolts, screws, drain plugs, and other items during service.
- 007000 Safe-T-Break Drain Cup
- Safe-T-Break Drain Cup allows for pressure relief making reconnecting easier.
- Safe-T-Break Drain Cup safely collects fuel to avoid spills when changing or reconnecting breakaways.
- Safe-T-Break Drain Cup can be used with all brands of breakaways- even non-reconnectable versions.

Filter Cups

MODEL NO.	DESCRIPTION	SHIPPING WEIGHT LBS (KG)
007004	Filter Cup, 5.8"H x 3.60" Base ID	.53 (.24)
008071	Filter Cup, 5.85"H x 4.98" Base ID	.71 (.32)
016506	Filter Cup, 7.5"H x 4.98" Base ID	.88 (.40)
016664	Filter Cup, 7.5"H x 3.85" Base ID	.70 (.32)
016642	Filter Cup, 3.85"H x 2.88" Base ID	.21 (.09)

Safe-T-Break Drain Cup

MODEL NO.	DESCRIPTION	SHIPPING WEIGHT LBS (KG)
007000	Safe-T-Break Drain Cup	.13 (.06)



 WARNING: Cancer and Reproductive Harm - www.P65Warnings.ca.gov

Full Filter & Drain Cups

Safe and Clean filter removal.

Dimensions

MODEL NO. 008071



MODEL NO. 007004



MODEL NO. 016642



MODEL NO. 016506



MODEL NO. 016664



MODEL NO. 007000

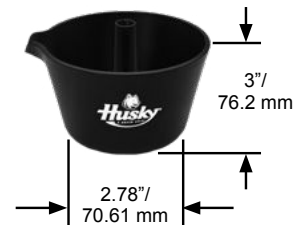

Guard Color Chart

COLOR	SUFFIX	COLOR	SUFFIX	COLOR	SUFFIX	COLOR	SUFFIX	COLOR	SUFFIX	COLOR	SUFFIX
Blue	-01	Black	-04	Gold	-08	M Blue	-21	Apple Green	-18 <i>CUSTOM</i>	BPS Green	-22 <i>CUSTOM</i>
Red	-02	Yellow	-05	Silver	-09	Orange	-39	Purple	-19 <i>CUSTOM</i>		
Green	-03	White	-06	BP Green	-16	Amoco Blue	-07 <i>CUSTOM</i>	Pink	-20 <i>CUSTOM</i>		

Scuff Guards are to be ordered with the corresponding guard color option added to the model number. Example: If BLUE guards are desired, add guard color option -01 to the model number (159504-01). For custom colors, a minimum order of 4,000 guards will be required. Custom logos for private branding are available. Email sales@husky.com for more information.



GENERAL FUELING PRODUCTS

Flo-Equalizers®

Flo-Equalizer®

Husky Flo-Equalizers® limit fuel flow to a maximum 10 gpm / 37.9 Lpm to comply with Comprehensive Environmental Response, Compensation, and Liability Act.

- All Husky Flo-Equalizers® are pressure compensating and allow full advantage of high capacity pumps.
- Low pressure loss at flows less than 10 gpm / 37.9 Lpm.

Model 004490

- For conventional systems.
- Installs in-line within the fuel line.
- Comes standard with pipe nipple for easy installation.

Model 005827

- For balance vapor recovery systems.
- Installs directly into the dispenser outlet casting.

Model 005837

- For vacuum assist vapor recovery systems.
- Installs directly into the dispenser outlet casting.

Model 007490

- For conventional nozzles with 3/4" / 19 mm inlet.
- Installs into nozzle inlet.

Flo-Equalizer®

MODEL NO.	DESCRIPTION	SHIPPING WEIGHT LBS (KG)
004490	3/4" F x 3/4" F NPT threads	.37 (0.16)
005827	1 1/8" x 12 threads	.43 (0.19)
005837	M34 x 1.5 threads	.37 (0.16)
007490	Internal use only	.02 (0.01)

Construction

Body	004490, 005827 and 005837: Aluminum 007490: Plastic
Seals	004490 and 700490: N/A 005827 and 005837: Fluorocarbon



Model 004490



Model 005827

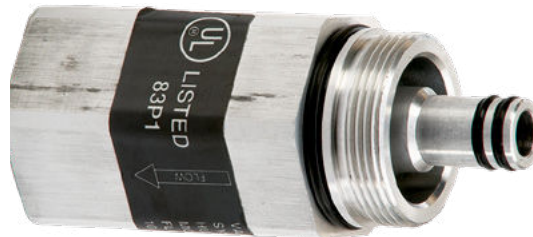

Model 005837



Model 007490



 WARNING: Cancer and Reproductive Harm - www.P65Warnings.ca.gov

Flo-Equalizer®

For nozzles and Safe-T-Breaks® Husky Flo-Equalizers® limit fuel flow to a maximum 10 gpm / 37.9 Lpm to comply with Comprehensive Environmental Response, Compensation, and Liability Act.

Dimensions and System Options

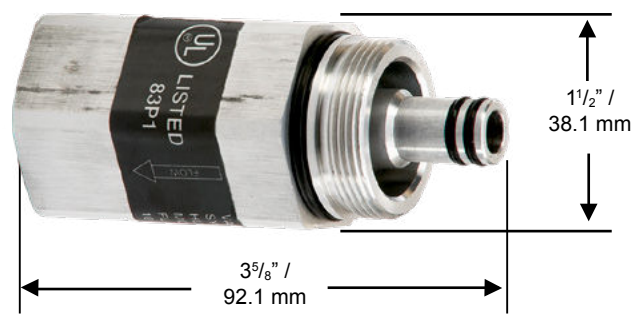
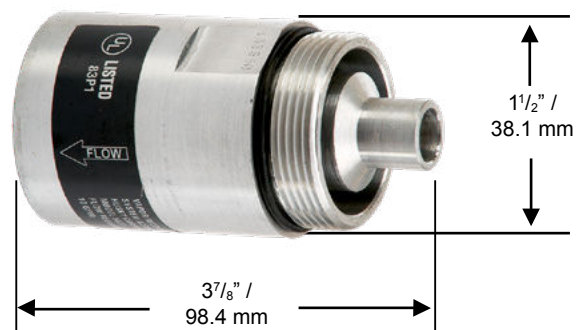



GENERAL FUELING PRODUCTS

DEF Adaptors

DEF Adaptors

Diesel Exhaust Fueling Adaptors

- 007214, 007285, 007356, 008413, 010579, 010675, 011477 and 012872 adaptors have stainless steel construction.
- 010227, 010549, 010551 and 010553 adaptors have polymer construction.
- 007214, 007285, 007356 and 008413 adaptors are UL recognized components and certified for DEF.

Diesel Exhaust Adaptors

MODEL NO.	DESCRIPTION	SHIPPING WEIGHT LBS (KG)
007214	Hose Barb 3/4" ID Hose x 3/4" BSPP with Seal Kit	.22 (.10)
007285	1" M x 1" M BSPP Straight Adaptor	.29 (.13)
007356	1" M BSPP x M M34 Straight Adaptor	.30 (.13)
008413	Hose Barb 3/4" ID Hose x 1" BSPP with Seal Kit	.29 (.13)
010227	1" F BSPP Adaptor	.20 (.10)
010549	1" F BSPP x 1" NPT Adaptor	.20 (.10)
010551	1" F BSPP x 3/4" NPT Adaptor	.20 (.10)
010553	1" F BSPP x 3/4" BSP Adaptor	.20 (.10)
010579	1" F BSPP x 3/4" Hose Barb Adaptor	.20 (.10)
010675	1" F x 1" F BSPP Straight Adaptor	.20 (.10)
011477	1" M BSPP x 3/4" F NPT Straight Adaptor	.22 (.10)
012872	1" M BSPP x 3/4" F BSPP Straight Adaptor	.22 (.10)



WARNING: Cancer and Reproductive Harm - www.P65Warnings.ca.gov

DEF Adaptors

Diesel Exhaust Fueling Adaptors.

Dimensions and System Options

Accessories

MODEL NO.	DESCRIPTION
007406	3/4" DEF Seal Kit
007407	1" DEF Seal Kit

Model 007214

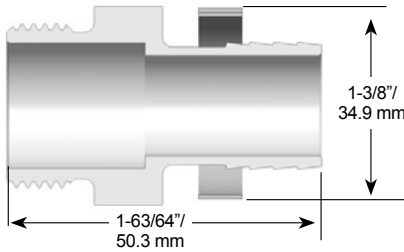

Model 007285

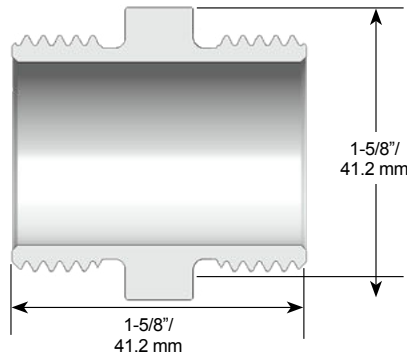

Model 007356

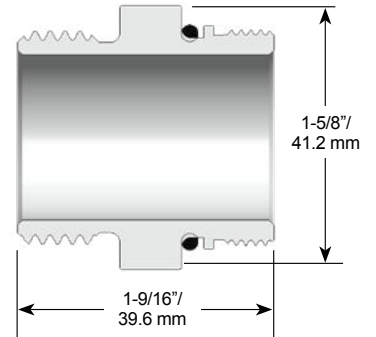

Model 008413

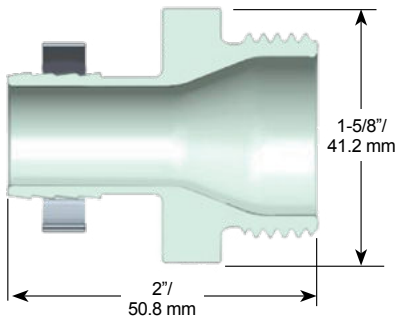

Model 010579

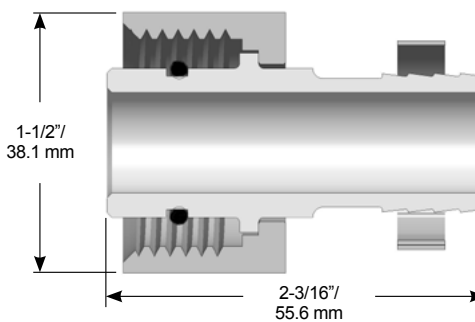

Model 010675

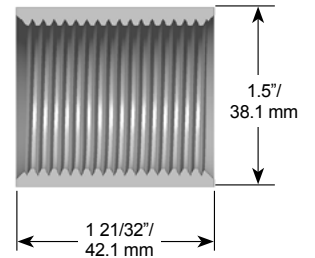

Model 010227

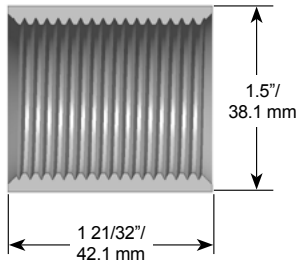

Model 010549

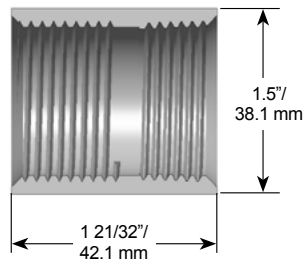

Model 010551

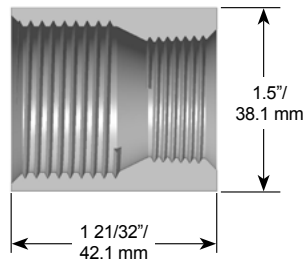

Model 010553

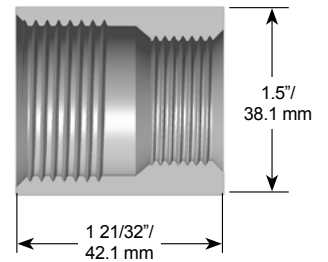

Model 011477 & 012872

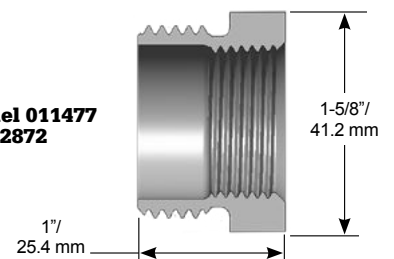

Rev 6 1/20



Husky[®]

GENERAL FUELING PRODUCTS

Hoses

EagleFlex® Hardwall

Premium Hardwall Gasoline Pump Hose

- Recommended anywhere a hardwall hose is required.
- Resists kinking and eliminates meter creep.
- Recommended for all gasoline and gasoline/Ethanol blends at Ethanol levels designated as “gasohol” (E15 maximum or less), diesel fuel and diesel fuel/biodiesel blends with nominal biodiesel concentrations up to 20% (B0-B20), kerosene and fuel oil (heating oil), leaded and unleaded gasoline.
- Improves ozone and abrasion resistance while providing increased life.
- Improves draping and handling characteristics.
- Will not mark or scratch vehicle finishes.
- Hose material is private branded and UL Listed to UL 330 and CAN/ULC-5612-99.
- All curb pump hose assemblies are 100% pressure tested, inspected for electrical continuity and sample pull tested.
- Designed for durability, flexibility, and easy handling.
- Highly resistant to cuts, abrasions, sun and weather.

(See page two for coupling descriptions)

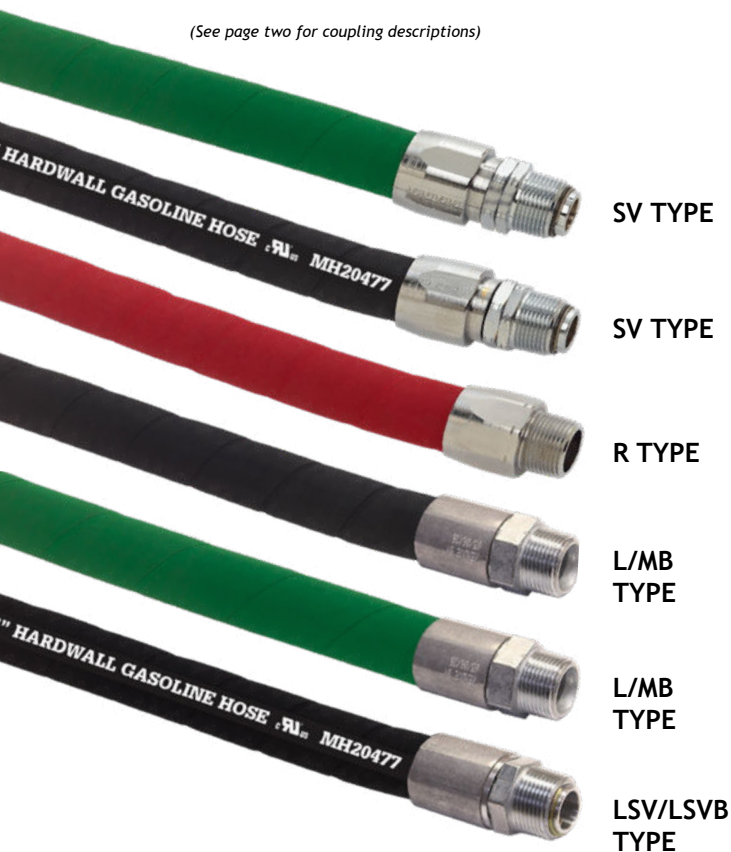

Hardwall Hoses

MODEL NO.	DESCRIPTION	SHIPPING WEIGHT LBS (KG)
5/8" HOSES		
CP10HW09	5/8" Hardwall 9' Assembly Hose	3.5 (1.6)
3/4" HOSES		
CP12HWG08	3/4" Green Hardwall 8' Assembly Hose	3.8 (1.7)
CP12HWG09	3/4" Green Hardwall 9' Assembly Hose	4.2 (1.9)
CP12HWG10	3/4" Green Hardwall 10' Assembly Hose	4.7 (2.1)
CP12HWG12SV	3/4" Green Hardwall 12' Assembly Hose Swivel	5.6 (2.5)
CP12HW09	3/4" Hardwall 9' Assembly Hose	4.2 (1.9)
CP12HW09.5	3/4" Hardwall 9.5' Assembly Hose	4.5 (2.0)
CP12HW09SV	3/4" Hardwall 9' Assembly Hose Swivel	4.2 (1.9)
CP12HW12	3/4" Hardwall 12' Assembly Hose	5.6 (2.5)
CP12HW14	3/4" Hardwall 14' Assembly Hose	6.6 (3.0)
CP12HW17	3/4" Hardwall 17' Assembly Hose	8.0 (3.6)
CP12HW01L	3/4" Hardwall 14' Assembly Hose	6.6 (3.0)
CP12HWR01L	3/4" Hardwall 14' Assembly Hose	6.6 (3.0)
CP12HW01LSV	3/4" Hardwall 14' Assembly Hose	6.6 (3.0)

1" HOSES

CP16HW01	1" Hardwall 1' Assembly Hose	0.64 (0.95)
CP16HW06	1" Hardwall 6' Assembly Hose	3.8 (1.7)
CP16HW10	1" Hardwall 10' Assembly Hose	6.4 (2.9)
CP16HW10X	1" Hardwall 10' Assembly Hose Bulk	6.4 (2.9)
CP16HW15	1" Hardwall 15' Assembly Hose	9.6 (4.4)
CP16HW15X	1" Hardwall 15' Assembly Hose Bulk	9.6 (4.4)
CP16HW17	1" Hardwall 17' Assembly Hose	10.9 (4.9)
CP16HW20X	1" Hardwall 20' Assembly Hose Bulk	12.8 (5.8)

Construction

Tube	Black Nitrile
Cover	Black CPE (chlorinated polyethylene), wrap impression
Reinforcement	Multiple textile braids with dual static wire helix
Temperature Range	-40° F to +180° F (-40° C to +82° C)
Body	3/4" Green Hardwall Available



EagleFlex® Hardwall

Premium Hardwall Gasoline Pump Hose

Dimensions and System Options

Available in these Sizes

ID Size	NOM OD		MAX WP		WEIGHT	
	IN	MM	PSI	MPA	LB/FT	KG/M
5/8" 16	1.03	26	150	1.03	0.39	0.58
3/4" 19	1.17	30	150	1.03	0.47	0.70
1" 25	1.45	37	150	1.03	0.64	0.95

Couplings

Permanent internally expanded fixed chrome plated brass or external crimp zinc (L type).

Reattachable fixed and Reattachable swivel 3/4" and 1" male NPT. U L does not recognize field installation of reattachable fittings.



EagleFlex® Softwall

Softwall Gasoline Pump Hose

- A lightweight, flexible hose for use when a hardwall hose is inappropriate.
- Recommended for all gasoline and gasoline/Ethanol blends at Ethanol levels designated as “gasohol” (E15 maximum or less), diesel fuel and diesel fuel/biodiesel blends with nominal biodiesel concentrations up to 20% (B0-B20), kerosene and fuel oil (heating oil), leaded and unleaded gasoline.
- Excellent strength without sacrificing flexibility.
- Highly resistant to cuts, abrasions, sun and weather.
- Smooth cover will not mark or scratch vehicle finishes.
- All curb pump hose assemblies are 100% pressure tested, inspected for electrical continuity and sample pull tested.



Softwall Hoses

MODEL NO.	DESCRIPTION	SHIPPING WEIGHT LBS (KG)
3/4" HOSES		
CP12SW09	3/4" Softwall 9' Assembly Hose	3.1 (1.4)
CP12SW10	3/4" Softwall 10' Assembly Hose	3.4 (1.5)
CP12SW10X	3/4" Softwall 10' Assembly Hose Bulk	3.4 (1.5)
CP12SW12	3/4" Softwall 12' Assembly Hose	4.1 (1.9)
CP12SW14	3/4" Softwall 14' Assembly Hose	4.8 (2.2)
CP12SW14X	3/4" Softwall 14' Assembly Hose Bulk	4.8 (2.2)
CP12SW17	3/4" Softwall 17' Assembly Hose	5.8 (2.6)
CP12SW20	3/4" Softwall 20' Assembly Hose	6.8 (3.1)
CP12SW30	3/4" Softwall 30' Assembly Hose	10.2 (4.6)
CP12SW50	3/4" Softwall 50' Assembly Hose	17.0 (7.7)
CP12SW9.5	3/4" Softwall 9.5' Assembly Hose	3.2 (1.5)
1" HOSES		
CP16SW10	1" Softwall 10' Assembly Hose	4.7 (2.1)
CP16SW12	1" Softwall 12' Assembly Hose	5.6 (2.5)
CP16SW14	1" Softwall 14' Assembly Hose	6.6 (3.0)
CP16SW14X	1" Softwall 14' Assembly Hose Bulk	6.6 (3.0)
CP16SW17	1" Softwall 17' Assembly Hose	8.0 (3.6)
CP16SW20	1" Softwall 20' Assembly Hose	9.4 (4.3)
CP16SW20X	1" Softwall 20' Assembly Hose Bulk	9.4 (4.3)
CP16SW60	1" Softwall 60' Assembly Hose	28.2 (12.8)

Construction

Tube	Black Nitrile
Cover	Black CPE (chlorinated polyethylene), smooth finish
Reinforcement	Multiple textile braids static wire
Temperature Range	-40° F to +180° F (-40° C to +82° C)



WARNING: Cancer and Reproductive Harm - www.P65Warnings.ca.gov

EagleFlex® Softwall

Softwall Gasoline Pump Hose

Dimensions and System Options

Available in these Sizes

ID size	NOM OD		MAX WP		WEIGHT	
	MM	IN	PSI	MPA	LB/FT	KG/M
3/4" 19	1.10	28	150	1.03	0.34	0.51
1" 25	1.39	35	150	1.03	0.47	0.63

Couplings

Permanent internally expanded fixed chrome plated brass or external crimp zinc (L type).

Reattachable fixed and Reattachable swivel 3/4" and 1" male NPT. U L does not recognize field installation of reattachable fittings.



EagleFlex® Wirebraid

Premium Hardwall Gasoline Pump Hose

- Recommended anywhere a hardwall or softwall hose is inappropriate.
- Recommended for all gasoline and gasoline/Ethanol blends at Ethanol levels designated as “gasohol” (E15 maximum or less), diesel fuel and diesel fuel/biodiesel blends with nominal biodiesel concentrations up to 20% (B0-B20), kerosene and fuel oil (heating oil), leaded and unleaded gasoline.
- Resistant to crushing and stands up to run-over.
- Highly resistant to cuts,
- Flexibility of a softwall, durability of a hardwall.
- Assures accurate readings at the pump.
- Will not mark or scratch vehicle finishes.
- Hose material is private branded and UL Listed to UL 330 and CAN/ULC-S612-99.
- All curb pump hose assemblies are 100% pressure tested, inspected for electrical continuity and sample pull tested.



X TYPE

L/MB TYPE

R/SV TYPE

L SV/L SVB TYPE

Wirebraid Hoses

MODEL NO.	DESCRIPTION	SHIPPING WEIGHT LBS (KG)
5/8" HOSES		
CP10WB08	5/8" Wirebraid 8' Assembly Hose	2.8 (1.3)
CP10WB09	5/8" Wirebraid 9" Assembly Hose	0.26 (0.12)
CP10WB09.5	5/8" Wirebraid 9.5' Assembly Hose	3.3 (1.5)
CP10WB10	5/8" Wirebraid 10' Assembly Hose	3.5 (1.6)
CP10WB14	5/8" Wirebraid 14' Assembly Hose	4.9 (2.2)
CP10WB9.5X	5/8" Wirebraid 9.5' Assembly Hose Bulk	3.3 (1.5)
3/4" HOSES		
CP12WB04	3/4" Wirebraid 4' Assembly Hose	1.7 (0.8)
CP12WB05	3/4" Wirebraid 5' Assembly Hose	2.1 (1.0)
CP12WB06	3/4" Wirebraid 6' Assembly Hose	2.5 (1.1)
CP12WB08	3/4" Wirebraid 8' Assembly Hose	3.4 (1.5)
CP12WB09	3/4" Wirebraid 9' Assembly Hose	3.8 (1.7)
CP12WB09SV	3/4" Wirebraid 9' Assembly Hose Swivel	3.8 (1.7)
CP12WB10	3/4" Wirebraid 10' Assembly Hose	4.2 (1.9)
CP12WB10X	3/4" Wirebraid 10' Assembly Hose Bulk	4.2 (1.9)
CP12WB12	3/4" Wirebraid 12' Assembly Hose	5.0 (2.3)
CP12WB12SV	3/4" Wirebraid 12' Assembly Hose Swivel	5.0 (2.3)
CP12WB12X	3/4" Wirebraid 12' Assembly Hose Bulk	5.0 (2.3)
CP12WB14	3/4" Wirebraid 14' Assembly Hose	5.9 (2.7)
CP12WB15SV	3/4" Wirebraid 15' Assembly Hose Swivel	6.3 (2.9)
CP12WB16	3/4" Wirebraid 16' Assembly Hose	6.7 (3.0)
CP12WB20	3/4" Wirebraid 20' Assembly Hose	8.4 (3.8)
CP12WB50X	3/4" Wirebraid 50' Assembly Hose Bulk	21.0 (9.5)
CP12WB01L	3/4" Wirebraid 14' Assembly Hose	5.9 (2.7)
CP12WB01SV	3/4" Wirebraid 14' Assembly Hose	5.9 (2.7)
CP12WB01LSV	3/4" Wirebraid 14' Assembly Hose	5.9 (2.7)
1" HOSES		
CP16WB04	1" Wirebraid 4' Assembly Hose	2.0 (0.9)
CP16WB06	1" Wirebraid 6' Assembly Hose	3.0 (1.4)
CP16WB08	1" Wirebraid 8' Assembly Hose	4.0 (1.8)
CP16WB09	1" Wirebraid 9' Assembly Hose	4.5 (2.0)
CP16WB10	1" Wirebraid 10' Assembly Hose Bulk	5.0 (2.3)
CP16WB10X	1" Wirebraid 10' Assembly Hose	5.0 (2.3)
CP16WB100SV	1" Wirebraid 100' Assembly Hose Swivel	50.0 (22.7)
CP16WB100SVSV	1" Wirebraid 100' Assembly Hose w/ Swivel on both ends	50.0 (22.7)
CP16WB12	1" Wirebraid 12' Assembly Hose	6.0 (2.7)
CP16WB12SV	1" Wirebraid 12' Assembly Hose Swivel	6.0 (2.7)
CP16WB13	1" Wirebraid 13' Assembly Hose	6.5 (3.0)
CP16WB14	1" Wirebraid 14' Assembly Hose	7.0 (3.2)
CP16WB14X	1" Wirebraid 14' Assembly Hose Bulk	7.0 (3.2)
CP16WB16	1" Wirebraid 16' Assembly Hose	8.0 (3.6)
CP16WB18	1" Wirebraid 18' Assembly Hose	9.0 (4.1)
CP16WB18X	1" Wirebraid 18' Assembly Hose Bulk	9.0 (4.1)
CP16WB20	1" Wirebraid 20' Assembly Hose	10.0 (4.5)
CP16WB20X	1" Wirebraid 20' Assembly Hose Bulk	10.0 (4.5)
CP16WB30	1" Wirebraid 30' Assembly Hose	15.0 (6.8)
CP16WB50SV	1" Wirebraid 50' Assembly Hose Swivel	25.0 (11.3)



WARNING: Cancer and Reproductive Harm - www.P65Warnings.ca.gov

EagleFlex® Wirebraid

Premium Hardwall Gasoline Pump Hose

Dimensions and System Options

Construction

Tube	Black Nitrile
Cover	Black CPE (chlorinated polyethylene), wrap impression
Reinforcement	One wirebraid with full diameter grounding sheath
Temperature Range	-40°F to +180°F (-40°C to +82°C)

Available in these Sizes

Size	NOM OD		MAX WP		WEIGHT	
	IN	MM	PSI	MPA	LB/FT	KG/M
5/8" 16	0.97	25	150	1.03	0.35	0.52
3/4" 19	1.10	28	150	1.03	0.42	0.63
1" 25	1.34	34	150	1.03	0.50	0.74

Couplings

or external crimp zinc (L type).
 Reattachable fixed (R type) and reattachable swivel (SV type) 3/4" and 1" male NPT. U L does not recognize field installation of reattachable fittings.

External crimp zinc swivel 3/4" and 1" male NPT (L SV type) or 3/4" male BSPP (L SVB type).

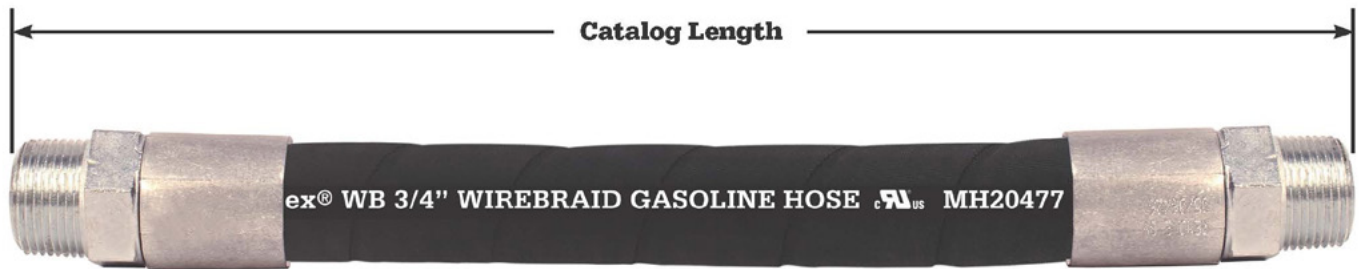

EagleFlex[®] Farm Tank

Gasoline Hose Assemblies with Static Wire

- Designed for durability and flexibility.
- Oil and abrasion resistant.
- Supplied with static wire.
- Recommended for use with electric pumps.
- Static wire hose always recommended with electric motors.
- Designed for use in agricultural, industrial and construction maintenance applications.
- Engineered for dispensing gasoline, diesel, kerosene and oil from farm and barrel-type pumps where UL approval is not required.
- Curb pump hose recommended for:
 - UL Listed hose material requirements.
 - For high aromatics or severe applications.
- All Farm Tank hose assemblies are 100% inspected for electrical continuity.
- Do not use these hoses at a service station or to refuel aircraft.

Farm Fueling Hoses

MODEL NO.	DESCRIPTION	SHIPPING WEIGHT LBS (KG)
3/4" HOSES		
FT012S10	3/4" x 10' Farm Tank Assembly Hose Bulk	2.9 (1.3)
FT012S12	3/4" x 12' Farm Tank Assembly Hose Bulk	3.5 (1.6)
FT012S12B	3/4" x 12' Farm Tank Assembly Hose Boxed	3.5 (1.6)
FT012S14	3/4" x 14' Farm Tank Assembly Hose Bulk	4.1 (1.9)
FT012S14B	3/4" x 14' Farm Tank Assembly Hose Boxed	4.1 (1.9)
FT012S15	3/4" x 15' Farm Tank Assembly Hose Bulk	4.4 (2.0)
FT012S15B	3/4" x 15' Farm Tank Assembly Hose Boxed	4.4 (2.0)
FT012S17	3/4" x 17' Farm Tank Assembly Hose Bulk	4.9 (2.2)
FT012S20	3/4" x 20' Farm Tank Assembly Hose Bulk	5.8 (2.6)
FT012S20B	3/4" x 20' Farm Tank Assembly Hose Boxed	5.8 (2.6)
1" HOSES		
FT016S10	1" x 10' Farm Tank Assembly Hose Bulk	4.5 (2.0)
FT016S12	1" x 12' Farm Tank Assembly Hose Bulk	5.4 (2.4)
FT016S12B	1" x 12' Farm Tank Assembly Hose Boxed	5.4 (2.4)
FT016S14	1" x 14' Farm Tank Assembly Hose Bulk	6.3 (2.9)
FT016S15	1" x 15' Farm Tank Assembly Hose Bulk	6.8 (3.1)
FT016S15B	1" x 15' Farm Tank Assembly Hose Boxed	6.8 (3.1)
FT016S17	1" x 17' Farm Tank Assembly Hose Bulk	7.7 (3.5)
FT016S20	1" x 20' Farm Tank Assembly Hose Bulk	9.0 (4.1)
FT016S20B	1" x 20' Farm Tank Assembly Hose Boxed	9.0 (4.1)
FT016S25	1" x 25' Farm Tank Assembly Hose Bulk	11.3 (5.1)

Construction

Tube	NBR, RMA Class A
Cover	NBR/PVC RMA Class A
Reinforcement	Spiral high tensile strength polyester cord
Temperature Range	-20°F to +160°F (-29°C to +71°C)



WARNING: Cancer and Reproductive Harm - www.P65Warnings.ca.gov

EagleFlex[®] Farm Tank

Gasoline Hose Assemblies with Static Wire

Dimensions and System Options

Available in these Sizes

Size	ID		NOM OD		WEIGHT	
	MM	IN	MM	IN	LB/FT	KG/M
3/4"	19	1.13	29	1.13	0.29	0.43
1"	25	1.38	35	1.38	0.45	0.67

Couplings

Permanent externally crimped 3/4" and 1" NPT.



Whip Hoses

HARDWALL WHIP HOSE:

- Recommended anywhere a hardwall hose is required.
- Highly resistant to cuts, abrasions, sun and weather.
- Improves ozone and abrasion resistance while providing increased life.

WIREBRAID WHIP HOSE:

- Recommended anywhere a hardwall or softwall hose is inappropriate.
- Provides full flow with no internal spring guards and will withstand full suction.
- Highly resistant to cuts, abrasions, sun and weather.
- Flexibility of a softwall, durability of a hardwall.

SOFTWALL WHIP HOSE:

- A lightweight, flexible hose for use when a hardwall hose is inappropriate.
- Highly resistant to cuts, abrasions, sun and weather.

ALL WHIP HOSES:

- Recommended for all gasoline and gasoline/Ethanol blends at Ethanol levels designated as “gasohol” (E15 maximum or less), diesel fuel and diesel fuel/biodiesel blends with nominal biodiesel concentrations up to 20% (B0-B20), kerosene and fuel oil (heating oil), leaded and unleaded gasoline.
- Hose Material is private branded and UL listed.
- All curb pump hose assemblies are 100% pressure tested, inspected for electrical continuity and sample pull tested.

Whip Hoses

MODEL NO.	DESCRIPTION	SHIPPING WEIGHT LBS (KG)
5/8" HOSES		
CP10HW.75	5/8" Hardwall 9" Assembly Hose	0.3 (0.14)
CP10HW.75L	5/8" Hardwall low cost 9" Assembly Hose	0.3 (0.14)
CP10WB.75M	5/8" Wirebraided medium cost 9" Assembly Hose	0.3 (0.14)
CP10WB.75SV	5/8" Wirebraided Swivel 9" Assembly Hose	0.3 (0.14)
3/4" HOSES		
CP12HW.75	3/4" Hardwall 9" Assembly Hose	0.3 (0.14)
CP12HWG.75	3/4" Green Hardwall 9" Assembly Hose	0.3 (0.14)
CP12HW.75L	3/4" Hardwall low cost 9" Assembly Hose	0.3 (0.14)
CP12HW.75SV	3/4" Hardwall Swivel 9" Assembly Hose	0.3 (0.14)
CP12WB.75L	3/4" Wirebraided low cost 9" Assembly Hose	0.3 (0.14)
CP12WB.75SV	3/4" Wirebraided Swivel 9" Assembly Hose	0.3 (0.14)
1" HOSES		
CP16HW.75	1" Hardwall 9" Assembly Hose	0.5 (0.23)
CP16HW.75L	1" Hardwall low cost 9" Assembly Hose	0.5 (0.23)
CP16HW.75SV	1" Hardwall Swivel 9" Assembly Hose	0.5 (0.23)
CP16WB.75L	1" Wirebraided low cost 9" Assembly Hose	0.5 (0.23)
CP16WB.75SV	1" Wirebraided Swivel 9" Assembly Hose	0.5 (0.23)



WARNING: Cancer and Reproductive Harm - www.P65Warnings.ca.gov

Whip Hoses

Dimensions



DEF Dispensing

DEF hose assemblies without static wire

- Designed for durability and flexibility.
- Abrasion resistant.
- Supplied without static wire.
- Recommended for use with electric pumps or dispensers.
- Designed for any DEF dispensing applications.
- Engineered for dispensing DEF where UL approval is not required.
- Curb pump hose recommended for:
 - UL Listed hose material requirements.
 - For high aromatics or severe applications.
- All DEF hose assemblies are 100% inspected for pressure to 50 psi.

(See page two for coupling descriptions)



GP/GPM
TYPE

AN TYPE

ANB/ANF
TYPE

ANF/ANMF
TYPE

DEF Fueling Hoses

MODEL NO.	DESCRIPTION	SHIPPING WEIGHT LBS (KG)
3/4" HOSES		
CP12DF10GP	3/4" x 10' DEF Assembly Hose	2.9 (1.3)
CP12DF12GP	3/4" x 12' DEF Assembly Hose	3.5 (1.6)
CP12DF12GPX	3/4" x 12' DEF Assembly Hose Bulk	3.5 (1.6)
CP12DF14GP	3/4" x 14' DEF Assembly Hose	4.1 (1.9)
CP12DF15GPX	3/4" x 15' DEF Assembly Hose Bulk	4.4 (2.0)
CP12DF17GP	3/4" x 17' DEF Assembly Hose	4.9 (2.2)
CP12DF20GP	3/4" x 20' DEF Assembly Hose	5.8 (2.6)
CP12DF20GPX	3/4" x 20' DEF Assembly Hose Bulk	5.8 (2.6)
CP12DF10AN	3/4" x 10' DEF Assembly Hose w/ 3/4" NPT aluminum fittings	2.9 (1.3)
CP12DF10ANB	3/4" x 10' DEF Assembly Hose with 3/4" BSPP Aluminum Fittings	2.9 (1.3)
CP12DF10ANF	3/4" x 10' DEF Assembly Hose with 1" Female BSPP Fittings	2.9 (1.3)

Construction

Tube	Black customized peroxide-cured EPDM
Cover	Black customized EPDM with smooth finish
Reinforcement	Multiple textile plies
Temperature Range	-40° F to +212° F (-40° C to +100° C)



WARNING: Cancer and Reproductive Harm - www.P65Warnings.ca.gov

DEF Dispensing

DEF hose assemblies without static wire

Dimensions and System Options

Available in these Sizes

ID		NOM OD		MAX WP		WEIGHT	
Size	MM	IN	MM	LB/FT	KG/M	LB/FT	KG/M
3/4"	19	1.13	29	150	1.03	0.29	0.43

Couplings

Permanent externally crimped 3/4" NPT polypropylene stem with brass ferrule (GP type) or 3/4" BSPP (GPM type)

Permanent externally crimped 3/4" NPT anodized aluminum stem with stainless steel ferrule (AN type)

Permanent externally crimped 3/4" BSPP anodized aluminum stem with stainless steel ferrule (ANB type)

Permanent externally crimped 1" female BSPP anodized aluminum stem with stainless steel ferrule (ANF type)

Permanent externally crimped 1" female & 3/4" male BSPP anodized aluminum stems with stainless steel ferrules (ANB type)



EagleFlex® Low Perm Hardwall

Premium Low Permeation Hardwall Gasoline Pump Hose

- Recommended anywhere a hardwall hose is required.
- Resists kinking and eliminates meter creep.
- Recommended for all gasoline and gasoline/Ethanol blends at Ethanol levels designated as “gasohol” (E10 maximum or less), diesel fuel and diesel fuel/biodiesel blends with nominal biodiesel concentrations up to 5% (B0-B5), kerosene and fuel oil (heating oil), leaded and unleaded gasoline where low permeation ($\leq 10\text{g/m}^2/\text{day}$) is required.
- Improves ozone and abrasion resistance while providing increased life.
- Improves draping and handling characteristics.
- Will not mark or scratch vehicle finishes.
- Hose material is private branded and UL Listed to UL 330 for low permeation.
- All curb pump hose assemblies are 100% pressure tested, inspected for electrical continuity and sample pull tested.
- Designed for durability, flexibility, and easy handling.
- Highly resistant to cuts, abrasions, sun and weather.

Low Perm Hardwall Hoses

MODEL NO.	DESCRIPTION	SHIPPING WEIGHT LBS (KG)
5/8" LP HOSES		
CP10LP8.5	5/8" Low Perm Hardwall 8.5' Assembly Hose	3.8 (1.7)
CP10LP10	5/8" Low Perm Hardwall 10' Assembly Hose	4.7 (2.1)
3/4" LP HOSES		
CP12LP8.5	3/4" Low Perm Hardwall 8.5' Assembly Hose	3.8 (1.7)
CP12LP8.5SV	3/4" Low Perm Hardwall 8.5' Assembly Hose Swivel	4.2 (1.9)
CP12LP9	3/4" Low Perm Hardwall 9' Assembly Hose	4.2 (1.9)
CP12LP9SV	3/4" Low Perm Hardwall 9' Assembly Hose Swivel	4.7 (2.1)
1" LP HOSES		
CP16LP8	1" Low Perm Hardwall 8' Assembly Hose	6.4 (2.9)
CP16LP14	1" Low Perm Hardwall 14' Assembly Hose	9.6 (4.4)

Construction

Tube	Black Nitrile
Cover	Black CPE (Chlorinated Polyethylene), wrap impression
Reinforcement	Multiple textile braids with dual static wire helix
Temperature Range	-40°F to +180°F (-40°C to +82°C)



WARNING: Cancer and Reproductive Harm - www.P65Warnings.ca.gov

EagleFlex[®] Low Perm Hardwall

Premium Low Permeation Hardwall Gasoline Pump Hose

Dimensions and System Options

Available in these Sizes

ID Size	NOM OD		MAX WP		WEIGHT	
	MM	IN	PSI	MPA	LB/FT	KG/M
5/8" 16	1.03	26	150	1.03	0.37	0.55
3/4" 19	1.17	30	150	1.03	0.44	0.65
1" 25	1.45	37	150	1.03	0.59	0.88

Couplings

Permanent, external crimp, zinc plated steel couplings, fixed and swivel



Whip Low Perm Hoses

- Recommended anywhere a hardwall hose is required.
- Recommended for all gasoline and gasoline/Ethanol blends at Ethanol levels designated as “gasohol” (E10 maximum or less), diesel fuel and diesel fuel/biodiesel blends with nominal biodiesel concentrations up to 5% (B0-B5), kerosene and fuel oil (heating oil), leaded and unleaded gasoline where low permeation ($\leq 10\text{g}/\text{m}^2/\text{day}$) is required.
- Designed for durability, flexibility, and easy handling.
- Highly resistant to cuts, abrasions, sun and weather.
- Resists kinking and eliminates meter creep.
- Improves ozone and abrasion resistance while providing increased life.
- Will not mark or scratch dispenser finishes.
- Hose material is private branded and UL Listed to UL 330 for low permeation.
- All curb pump hose assemblies are 100% pressure tested, inspected for electrical continuity and sample pull tested.

Whip Low Perm Hoses

MODEL NO.	DESCRIPTION	SHIPPING WEIGHT LBS (KG)
5/8" LP HOSES		
CP10LP.75	5/8" Low Perm Hardwall 9" Assembly Hose	0.72 (0.3)
CP10LP.75SV	5/8" Low Perm Hardwall 9" Swivel Assembly Hose	0.72 (0.3)
3/4" LP HOSES		
CP12LP.75	3/4" Low Perm Hardwall 9" Assembly Hose	1.00 (0.5)
CP12LP.75SV	3/4" Low Perm Hardwall 9" Swivel Assembly Hose	1.00 (0.5)
1" LP HOSES		
CP16LP.75	1" Low Perm Hardwall 9" Assembly Hose	1.20 (0.5)
CP16LP.75SV	1" Low Perm Hardwall 9" Swivel Assembly Hose	1.20 (0.5)



 WARNING: Cancer and Reproductive Harm - www.P65Warnings.ca.gov

Whip Low Perm Hoses

Dimensions and System Options

Available in these Sizes

Size	NOM OD		MAX WP		WEIGHT	
	IN	MM	PSI	MPA	LB/FT	KG/M
5/8" 16	1.03	26	150	1.03	0.37	0.55
3/4" 19	1.17	30	150	1.03	0.44	0.65
1" 25	1.45	37	150	1.03	0.59	0.88

Couplings

Permanent, external crimp, zinc plated steel couplings, fixed and swivel



Fuel Oil Hose

Fuel Oil Permanent Fitting fueling hose recommended for all home fuel oils, leaded and unleaded gasolines, and diesel and tractor fuels.

- Used for all home fuel oils, leaded and unleaded gasolines, and diesel and tractor fueling applications
- All fuel oil hose assemblies are 100% hydrostatic tested
- Resistant to flex fatigue
- Smooth cover gives it minimum ground drag, added freedom of movement and abrasion resistance

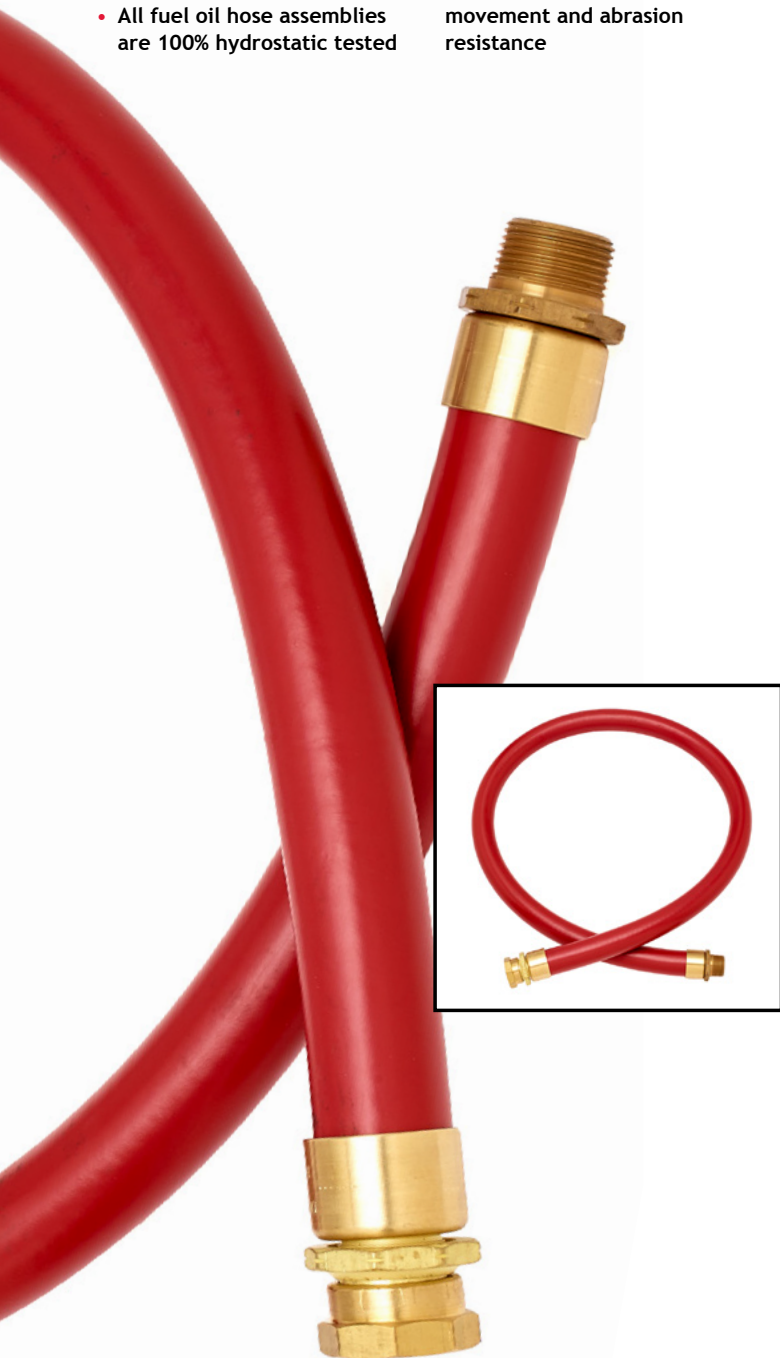

Specifying Information

MODEL NO.	DESCRIPTION	SHIPPING WEIGHT LBS (KG)
1" BULK HOSES		
9769	Hose, 1" Red Fuel Oil 100'	47 (21.3)
9769	Hose, 1" Red Fuel Oil 125'	59 (26.8)
9769	Hose, 1" Red Fuel Oil 150'	71 (32.2)
1 1/4" BULK HOSES		
9770	Hose, 1 1/4" Red Fuel Oil 100'	59 (26.8)
9770	Hose, 1 1/4" Red Fuel Oil 125'	74 (33.6)
9770	Hose, 1 1/4" Red Fuel Oil 150'	89 (40.4)
1 1/2" BULK HOSES		
9771	Hose, 1 1/2" Red Fuel Oil 100'	80 (36.3)
9771	Hose, 1 1/2" Red Fuel Oil 125'	100 (45.4)
9771	Hose, 1 1/2" Red Fuel Oil 150'	120 (54.4)
1" HOSES		
CP161200FABA	1" x 100' Red Fuel Oil Assy M x M	49 (22.2)
CP161200FBBA	1" x 100' Red Fuel Oil Assy M x F	49 (22.2)
CP161200FCBA	1" x 100' Red Fuel Oil Assy F x F	49 (22.2)
CP161500FABA	1" x 125' Red Fuel Oil Assy M x M	61 (27.7)
CP161500FBBA	1" x 125' Red Fuel Oil Assy M x F	61 (27.7)
CP161500FCBA	1" x 125' Red Fuel Oil Assy F x F	61 (27.7)
CP161800FABA	1" x 150' Red Fuel Oil Assy M x M	73 (33.1)
CP161800FBBA	1" x 150' Red Fuel Oil Assy M x F	73 (33.1)
CP161800FCBA	1" x 150' Red Fuel Oil Assy F x F	73 (33.1)
1 1/4" HOSES		
CP201200FABA	1 1/4" x 100' Red Fuel Oil Assy M x M	61 (27.7)
CP201200FBBA	1 1/4" x 100' Red Fuel Oil Assy M x F	61 (27.7)
CP201200FCBA	1 1/4" x 100' Red Fuel Oil Assy F x F	61 (27.7)
CP201500FABA	1 1/4" x 125' Red Fuel Oil Assy M x M	76 (34.5)
CP201500FBBA	1 1/4" x 125' Red Fuel Oil Assy M x F	76 (34.5)
CP201500FCBA	1 1/4" x 125' Red Fuel Oil Assy F x F	76 (34.5)
CP201800FABA	1 1/4" x 150' Red Fuel Oil Assy M x M	91 (41.3)
CP201800FBBA	1 1/4" x 150' Red Fuel Oil Assy M x F	91 (41.3)
CP201800FCBA	1 1/4" x 150' Red Fuel Oil Assy F x F	91 (41.3)
1 1/2" HOSES		
CP241200FABA	1 1/2" x 100' Red Fuel Oil Assy M x M	82 (37.2)
CP241200FBBA	1 1/2" x 100' Red Fuel Oil Assy M x F	82 (37.2)
CP241200FCBA	1 1/2" x 100' Red Fuel Oil Assy F x F	82 (37.2)
CP241500FABA	1 1/2" x 125' Red Fuel Oil Assy M x M	102 (46.3)
CP241500FBBA	1 1/2" x 125' Red Fuel Oil Assy M x F	102 (46.3)
CP241500FCBA	1 1/2" x 125' Red Fuel Oil Assy F x F	102 (46.3)
CP241800FABA	1 1/2" x 150' Red Fuel Oil Assy M x M	122 (55.3)
CP241800FBBA	1 1/2" x 150' Red Fuel Oil Assy M x F	122 (55.3)
CP241800FCBA	1 1/2" x 150' Red Fuel Oil Assy F x F	122 (55.3)

Construction

Tube	NBR, RMA Class A
Cover	NBR/PVC, RMA Class A
Reinforcement	4 spiral polyester yarn
Cover Color:	Red
Oil Resistance:	High, Medium-High
Temperature:	-20° F (-29° C) to +180° F (82° C)



WARNING: Cancer and Reproductive Harm - www.P65Warnings.ca.gov

Fuel Oil Hose

Fuel Oil Permanent Fitting fueling hose recommended for all home fuel oils, leaded and unleaded gasolines, and diesel and tractor fuels.

Dimensions and System Options

Available in these Sizes

ID Size	NOM OD		MAX WP		WEIGHT		
	MM	IN	PSI	MPA	LB/FT	KG/M	
1"	25	1.50	38.0	250	1.72	0.47	0.71
1 1/4"	32	1.78	45.2	250	1.72	0.59	0.87
1 1/2"	38	2.06	52.3	250	1.72	0.80	1.19

Couplings

Permanent Brass	Internally expanded fittings - male NPT and female NPS (swivel nut)
-----------------	---

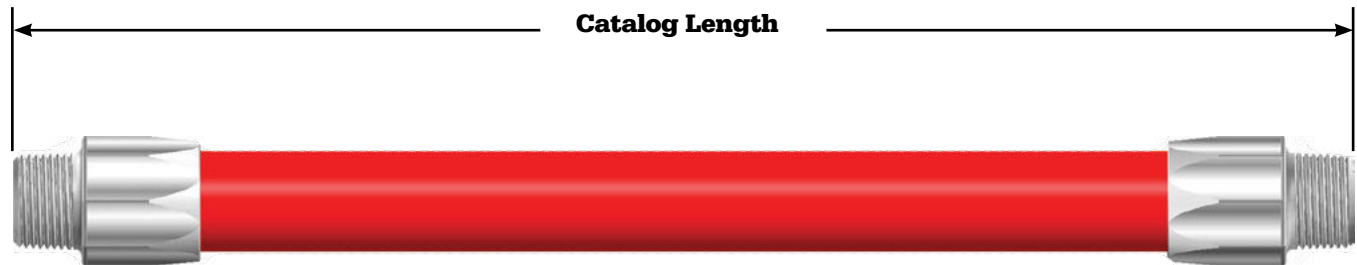

EagleFlex® E0-E85

E0-E85 Curb Pump Hose

- Recommended for use with Ethanol blends from E0 to E85.
- Resistant to crushing and stands up to run-over.
- Highly resistant to cuts, abrasions, sun and weather.
- Flexibility of a softwall, durability of a hardwall.
- Assures accurate readings at the pump.
- Will not mark or scratch vehicle finishes.
- Hose material is private branded and UL Listed to UL 330A and CAN/ULC-S612-99.
- All curb pump hose assemblies are 100% pressure tested, inspected for electrical continuity and sample pull tested.

E0-E85 Wirebraided Hoses

MODEL NO.	DESCRIPTION	SHIPPING WEIGHT LBS (KG)
3/4" HOSES		
CP12ET04	3/4" E0-E85 4' Assembly Hose	1.7 (0.8)
CP12ET05	3/4" E0-E85 5' Assembly Hose	2.1 (1.0)
CP12ET06	3/4" E0-E85 6' Assembly Hose	2.5 (1.1)
CP12ET09	3/4" E0-E85 9' Assembly Hose	3.8 (1.7)
CP12ET10	3/4" E0-E85 10' Assembly Hose	4.2 (1.9)
CP12ET10X	3/4" E0-E85 10' Assembly Hose Bulk	4.2 (1.9)
CP12ET12	3/4" E0-E85 12' Assembly Hose	5.0 (2.3)
CP12ET12X	3/4" E0-E85 12' Assembly Hose Bulk	5.0 (2.3)
CP12ET14	3/4" E0-E85 14' Assembly Hose	5.9 (2.7)
CP12ET16	3/4" E0-E85 16' Assembly Hose	6.7 (3.0)
CP12ET20	3/4" E0-E85 20' Assembly Hose	8.4 (3.8)
CP12ET50X	3/4" E0-E85 50' Assembly Hose Bulk	21.0 (9.5)

Whip Hoses

MODEL NO.	DESCRIPTION	SHIPPING WEIGHT LBS (KG)
3/4" HOSES		
CP12ET.75	3/4" E85 9" Assembly Hose	0.86 (0.39)
CP12ET.66	3/4" E85 8" Assembly Hose	0.82 (0.37)

Construction

Tube	Black Nitrile
Cover	Black CPE (chlorinated polyethylene), wrap impression
Reinforcement	One wirebraid with full diameter grounding sheath
Temperature Range	-40°F to +180°F (-40°C to +82°C)



 WARNING: Cancer and Reproductive Harm - www.P65Warnings.ca.gov

EagleFlex® E0-E85

E0-E85 Curb Pump Hose

Dimensions and System Options

Available in these Sizes

ID Size	NOM OD		MAX WP		WEIGHT	
	MM	IN	PSI	MPA	LB/FT	KG/M
3/4" 19	1.10	28	150	1.03	0.42	0.63

Couplings

Permanent externally crimped zinc (L type).





GENERAL FUELING PRODUCTS

EZ-Connect®

The only certified, pre-assembled, pressure and continuity-tested hanging hardware.

- Stage II Decommissioning Ready!
- Can also be configured for new station installs.
- Fully customizable.
- Available in 5/8", 3/4" and 1" assemblies.
- Pre-fabricated hanging hardware assembly.
- Includes choice of Hose/Dispenser adaptor (Balanced/Vac-Assist/Heavy).
- Robust multi-plane Husky® swivel.
- 3 types of hose material offered: Hardwall, Wirebraid and Softwall.
- Zinc Fittings
- Chrome-plated brass fittings.
- EZ-Connect® hoses assembled with UL/CUL certified components.
- Your choice of nozzle configuration.
- 100% continuity/pressure tested.
- Thread sealant used on all component connections (Gasola®).
- All required hanging hardware for decommissioning in one single package.



 WARNING: Cancer and Reproductive Harm - www.P65Warnings.ca.gov

EZ-Connect®

For nozzles and Safe-T-Breaks®

Thousands of conventional fuel pump combinations are available with **EZ-Connect's®** six interchangeable components, making it possible to design a pump package to meet specific fuel-dispensing needs.

This sample chart, using 5/8" Hardwall Hoses, demonstrates the many options available:

5/8" Connections/9' Hardwall Hoses Kits			
	w/002273 (Single Use) STB	w/003360 Reconnectable STB	w/008330 MagBreak®
Balance to Conventional Adaptor	006959	006959	006959
5/8" x 9" Hardwall Whip Hose	CP10HW.75	CP10HW.75	CP10HW.75
Safe-T-Break®	002273	003360	008330
5/8" x 9' Hardwall Curb Hose	CP10HW09	CP10HW09	CP10HW09
3/4" Multi-Plane Swivel	000350	000350	000350
New XS® Pressure Activated Automatic Nozzle w/1808 Splash Guard	159559	159559	159559

5/8" Connections/10' Hardwall Hoses Kits

	w/002273 (Single Use) STB	w/003360 Reconnectable STB	w/008330 MagBreak®
Balance to Conventional Adaptor	006959	006959	006959
5/8" x 9" Hardwall Whip Hose	CP10HW.75	CP10HW.75	CP10HW.75
Safe-T-Break®	002273	003360	008330
5/8" x 10' Hardwall Curb Hose	CP10HW10	CP10HW10	CP10HW10
3/4" Multi-Plane Swivel	000350	000350	000350
New XS® Pressure Activated Automatic	159559	159559	159559

This sample chart, using 3/4" Softwall DEF Hoses, demonstrates the many options available:

New X DEF Nozzle w/ 3/4" NPT Connections/9' Softwall DEF Hose Kits^

	w/012070 Reconnectable STB
3/4" 9" Softwall DEF Whip Hose	CP12DF.75AN
Safe-T-Break®	012070
3/4" 9' Softwall DEF Hose	CP12DF09AN
3/4" Roller Bearing Swivel	012604
New X DEF Automatic Nozzle w/004809 Splash Guard	11676155N

New Polymer DEF Nozzle w/ 3/4" NPT Connections/9' Softwall DEF Hose Kits^

	w/012070 Reconnectable STB
3/4" 9" Softwall DEF Whip Hose	CP12DF.75GP
Safe-T-Break®	012070
3/4" 9' Softwall DEF Hose	CP12DF09PB
New Polymer DEF Automatic Nozzle w/000216 Splash Guard	873504N

New X DEF Nozzle w/ 3/4" BSPP Connections/9' Softwall DEF Hose Kits^

	w/012659 Reconnectable STB
3/4" 9" Softwall DEF Whip Hose	CP12DF.75AB
Safe-T-Break®	012659
3/4" 9' Softwall DEF Hose	CP12DF09AB
3/4" Roller Bearing Swivel	012656
New X DEF Automatic Nozzle w/001808 Splash Guard, w/007361 Handle Guard	11676154N

^Not Listed